



888

# Operating Instructions

All rights reserved.  
Property of Dürkopp Adler GmbH and protected by copyright. Any reuse of these contents, including extracts,  
is prohibited without the prior written approval of Dürkopp Adler GmbH.

**Copyright © *Dürkopp Adler GmbH* - 2021**

# Foreword

This instruction manual is intended to help the user to become familiar with the machine and take advantage of its application possibilities in accordance with the recommendations.

The instruction manual contains important information on how to operate the machine securely, properly and economically. Observation of the instructions eliminates danger, reduces costs for repair and down-times, and increases the reliability and life of the machine.

The instruction manual is intended to complement existing national accident prevention and environment protection regulations.

The instruction manual must always be available at the machine/sewing unit.

The instruction manual must be read and applied by any person that is authorized to work on the machine/sewing unit. This means:

- Operation, including equipping, troubleshooting during the work cycle, removing of fabric waste,
- Service (maintenance, inspection, repair) and/or
- Transport.

The user also has to assure that only authorized personnel work on the machine.

The user is obliged to check the machine at least once per shift for apparent damages and to immediately report any changes (including the performance in service), which impair the safety.

The user company must ensure that the machine is only operated in perfect working order.

Never remove or disable any safety devices.

If safety devices need to be removed for equipping, repairing or maintaining, the safety devices must be remounted directly after completion of the maintenance and repair work.

Unauthorized modification of the machine rules out liability of the manufacturer for damage resulting from this.

Observe all safety and danger recommendations on the machine/unit! The yellow-and-black striped surfaces designate permanent danger areas, eg danger of squashing, cutting, shearing or collision.

Besides the recommendations in this instruction manual also observe the general safety and accident prevention regulations!

## General safety instructions

**The non-observance of the following safety instructions can cause bodily injuries or damages to the machine.**

1. The machine must only be commissioned in full knowledge of the instruction book and operated by persons with appropriate training.
2. Before putting into service also read the safety rules and instructions of the motor supplier.
3. The machine must be used only for the purpose intended. Use of the machine without the safety devices is not permitted. Observe all the relevant safety regulations.
4. When gauge parts are exchanged (e.g. needle, presser foot, needle plate, feed dog and bobbin) when threading, when the workplace is left, and during service work, the machine must be disconnected from the mains by switching off the master switch or disconnecting the mains plug.
5. Daily servicing work must be carried out only by appropriately trained persons.
6. Repairs, conversion and special maintenance work must only be carried out by technicians or persons with appropriate training.
7. For service or repair work on pneumatic systems, disconnect the machine from the compressed air supply system (max. 7-10 bar). Before disconnecting, reduce the pressure of the maintenance unit. Exceptions to this are only adjustments and functions checks made by appropriately trained technicians.
8. Work on the electrical equipment must be carried out only by electricians or appropriately trained persons.
9. Work on parts and systems under electric current is not permitted, except as specified in regulations DIN VDE 0105.
10. Conversion or changes to the machine must be authorized by us and made only in adherence to all safety regulations.
11. For repairs, only replacement parts approved by us must be used.
12. Commissioning of the sewing head is prohibited until such time as the entire sewing unit is found to comply with EC directives.
13. The line cord should be equipped with a country-specific mains plug. This work must be carried out by appropriately trained technicians (see paragraph 8).



It is absolutely necessary to respect the safety instructions marked by these signs.

**Danger of bodily injuries !**

Please note also the general safety instructions.



**Introduction and safety instructions**

**Part 1: Operating Instructions Class 888 - Original Instructions**

(Edition 02.2021)

<b>1</b>	<b>Product description</b> . . . . .	<b>5</b>
<b>2</b>	<b>Designated use</b> . . . . .	<b>5</b>
<b>3</b>	<b>Subclasses and sewing equipment</b>	
3.1	Subclasses . . . . .	6
3.2	Sewing equipment standard . . . . .	8
3.3	Sewing equipment special . . . . .	11
<b>4</b>	<b>Optional equipment</b> . . . . .	<b>13</b>
<b>5</b>	<b>Technical data</b> . . . . .	<b>15</b>
<b>6</b>	<b>Operation</b>	
6.1	Threading the needle thread . . . . .	17
6.2	Winding the hook thread . . . . .	18
6.3	Bobbin insertion and threading the hook thread . . . . .	18
6.4	Adjusting the thread tension. . . . .	19
6.4.1	Adjusting the hook thread tension . . . . .	19
6.4.2	Adjusting the needle thread tension . . . . .	20
6.5	Switching on/off the thread tensioners. . . . .	22
6.6	Adjusting the thread regulator. . . . .	23
6.7	Changing the needle with single-needle machines with the hook on the right . . . . .	24
6.8	Changing the needle with single-needle machines with the hook on the left . . . . .	25
6.9	Changing the needle with double-needle machines. . . . .	26
6.10	Lifting and folding the roller presser . . . . .	27
6.11	Sewing-foot pressure . . . . .	28
6.11.1	Setting through the setting wheel. . . . .	28
6.11.2	Constant sewing-foot pressure through the cylinder . . . . .	29
6.12	Sewing backward (backtacking) . . . . .	29
6.13	Setting the stitch length . . . . .	30
6.14	Switching on the safety clutch at the hook blocking. . . . .	31
6.15	Controlling the machine equipped with the positioning motor . . . . .	32
6.15.1	Using the pedal . . . . .	32
6.15.2	By the key panel 9880 867101 . . . . .	33
6.15.3	By the key panel 9880 888102 . . . . .	34
6.16	Lower edge trimming control . . . . .	35
6.16.1	Switching on/off edge trimmer . . . . .	35
6.16.2	Switching on/off material guide . . . . .	36
6.16.3	Material guide adjustment . . . . .	37

6.17	Upper oblique edge trimming control . . . . .	38
6.17.1	Switching on/off edge trimmer . . . . .	38
6.17.2	Material guide adjustment . . . . .	39
6.18	Disengaging the needle bar with subclass 888-460522 . . . . .	40
<b>7</b>	<b>Overview of positioning drives</b>	
7.1.	DAC basic/classic/eco . . . . .	41
7.1.1	DAC basic/classic . . . . .	41
7.1.2	DAC eco . . . . .	41
7.2	Efka DA321G/DC1550 . . . . .	42
<b>8</b>	<b>Sewing with machine equipped with positioning motor</b>	
8.1	Machine automatic functions . . . . .	43
8.2	Example of machine operation at sewing . . . . .	44
<b>9</b>	<b>Maintenance</b>	
9.1	Cleaning and checking . . . . .	45
9.2	Lubrication . . . . .	48

# 1 Product description

The **Dürkopp Adler 888** is a special sewing machine for universal use.

- It is a double lockstitch post bed sewing machine.
- It has a two step feed. A lower wheel feeder and a driven roller presser feed in two steps, a needle feed feeds in the first step only. In single and double needle machines, the first step represents 33% of the total stitch length.
- Depending on subclass, the machine is either single needle or double needle unit with automatic functions such as thread trimming, automatic backtacking, automatic foot lifting, or without them.
- The single needle machine can be equipped with lower or upper oblique edge trimming.
- The machine is equipped with a large or standard two part vertical hook.
- Maximum foot lift is 12 mm.
- The residual thread length after thread trimming is about 15 mm, after short thread trimming about 5 mm.
- The hook is protected with a safety clutch against the disarrangement of the adjusted position at the blocking of the thread which interfered with its way.
- The throat plate has replaceable inserts with the stitch hole dimension difference, which are optional in dependence on the needle number.
- The machine has automatic wick lubrication from the central oil tank with a visual check of the oil level by oil level indicator in the machine arm. The part of the oil with which the hook is lubricated is devaluated. The other part of the lubrication oil is returned to the central tank by a pump.
- Integrated bobbin winder.

EN

# 2 Designated use

The class **888** is designated for sewing shoe, leather, and upholstery sewing. In general, the material sewn is leather (natural or artificial). It is possible to use it for shoe fabrics too.

The equipment for light, medium or heavy sewing is mounted on the machine as an option.

The subclass with material trimming is designated especially for the shoe lining trimming if the lining has the corresponding strength. The cutting mechanism allows the lining trimming under the leather surface layer. It is possible to trim also all sewn layers simultaneously.

It is possible to sew dry material only which may not be thicker than 7 mm when pressed down with a roller presser. The material may not contain hard objects, as the machine is not equipped with an eye guard. This machine may be operated in dry rooms and by a trained person only who is aware of the risks described in this instruction.

This special sewing machine may be set up and operated only in dry, well-maintained premises. If the sewing machine is used in premises which are not dry and well-maintained it may be necessary to take further precautions (which should be agreed in advance - see EN 60204-31:1999).

As manufacturers of industrial sewing machines we proceed on the assumption that personnel who work on our products will have received training at least sufficient to acquaint them with all normal operations and with any hazards which these may involve.

### 3 Subclasses and sewing equipment

#### 3.1 Subclasses

<b>888-160020</b>	Single-needle double lockstitch post bed sewing machine with feed wheel, needle feed with driven roller foot and large hook.
<b>888-260020</b>	Double-needle double lockstitch post bed sewing machine with feed wheel, needle feed with driven roller foot and large hook.
<b>888-160122</b> <b>888-160122-M</b>	Single-needle double lockstitch post bed sewing machine with feed wheel, needle feed with driven roller foot and large hook, electro-magnetic thread cutter, electro-magnetic seam bartacking and sewing foot lifting. Short stitch equipment: By pressing a key on the machine head a complete stitch with shortened stitch length is sewn.
<b>888-260122</b> <b>888-260122-M</b>	Double-needle double lockstitch post bed sewing machine with feed wheel, needle feed with driven roller foot and large hook, electro-magnetic thread cutter, electro-magnetic seam bartacking and sewing foot lifting. Short stitch equipment: By pressing a key on the machine head a complete stitch with shortened stitch length is sewn.
<b>888-356020</b>	Single-needle double lockstitch post bed sewing machine with feed wheel, needle feed with driven roller foot and large hook, equipped with electro motor driven edge trimmer.
<b>888-356122</b> <b>888-356122-M</b>	Single-needle double lockstitch post bed sewing machine with feed wheel, needle feed with driven roller foot and large hook, electro-magnetic thread cutter, electro-magnetic seam bartacking and sewing foot lifting, equipped with electro motor driven edge trimmer. Short stitch equipment: By pressing a key on the machine head a complete stitch with shortened stitch length is sewn.
<b>888-160152</b> <b>888-160152-M</b>	Single-needle double lockstitch post bed sewing machine with feed wheel, needle feed with driven roller foot and regular hook, electro-magnetic thread cutter, electro-magnetic seam bartacking and sewing foot lifting. Short stitch equipment: By pressing a key on the machine head a complete stitch with shortened stitch length is sewn.
<b>888-356152</b>	Single-needle double lockstitch post bed sewing machine with feed wheel, needle feed with driven roller foot and regular hook, electro-magnetic thread cutter, electro-magnetic seam bartacking and sewing foot lifting, equipped with electro motor driven edge trimmer. Short stitch equipment: By pressing a key on the machine head a complete stitch with shortened stitch length is sewn.



<b>888-460522</b> <b>888-460522-M</b>	Double-needle double lockstitch post bed sewing machine with feed wheel, needle feed with driven roller foot, equipped with disengageable needle bar and large hook, electro-magnetic thread cutter, pneumatic second stitch length, seam bartacking and sewing foot lifting.
<b>888-360122</b> <b>888-360122-M</b>	Single-needle double lockstitch post bed sewing machine with feed wheel, needle feed with driven roller foot and large hook, electro-magnetic thread cutter, electro-magnetic seam bartacking and sewing foot lifting. Left narrow post. Short stitch equipment: By pressing a key on the machine head a complete stitch with shortened stitch length is sewn
<b>888-160023</b>	Single-needle double lockstitch post bed sewing machine with feed wheel, needle feed with driven roller foot and large hook, electro-magnetic thread cutter.
<b>888-260023</b>	Double-needle double lockstitch post bed sewing machine with feed wheel, needle feed with driven roller foot and large hook, electro-magnetic thread cutter.
<b>888-160053</b>	Single-needle double lockstitch post bed sewing machine with feed wheel, needle feed with driven roller foot and regular hook, electro-magnetic thread cutter.
<b>888-260053</b>	Double-needle double lockstitch post bed sewing machine with feed wheel, needle feed with driven roller foot and regular hook, electro-magnetic thread cutter.
<b>888-260152</b>	Double-needle double lockstitch post bed sewing machine with feed wheel, needle feed with driven roller foot and regular hook, electro-magnetic thread cutter, electro-magnetic seam bartacking and sewing foot lifting. Short stitch equipment: By pressing a key on the machine head a complete stitch with shortened stitch length is sewn.
<b>888-167020</b>	Single-needle double lockstitch post bed sewing machine with feed wheel, needle feed with driven roller foot and large hook. Equipped with electro motor driven upper oblique edge trimmer. Right post.
<b>888-167122</b> <b>888-167122-M</b>	Single-needle double lockstitch post bed sewing machine with feed wheel, needle feed with driven roller foot and large hook, electro-magnetic thread cutter, electro-magnetic seam bartacking and sewing foot lifting, equipped with electro motor driven upper oblique edge trimmer. Right post. Short stitch equipment: By pressing a key on the machine head a complete stitch with shortened stitch length is sewn.

**888-160125**  
**888-160125-M**

Single-needle double lockstitch post bed sewing machine with feed wheel, needle feed with driven roller foot and large hook, electro-magnetic short thread cutter, electro-magnetic seam bartacking and sewing foot lifting.

Short stitch equipment: By pressing a key on the machine head a complete stitch with shortened stitch length is sewn.

### 3.2 Sewing equipment standard

Sewing equipment	For classes and subclasses	Number of needles	Sewing category	Needle number		Polyester thread label number		Maximum stitch length	Sewing speed		Top roller diameter	Wheel feed tooth pitch	Seam distance	Trimming distance from the needle	
				Scope	Standard	Scope	Standard		Maximum	Standard *					
				0,01 mm	0,01mm	-	-		mm	1/min					1/min
888-E1	0888 160020 0888 160023 0888 160122 0888 160522	1	light	70-80	80	80-60	60	4	3000	2500	35	0,6	-	-	
888-E2			medium	90-110	90	50-30	40	5	2500	2500			-	-	
888-E3			heavy	120-160	120	25-10	20	7	2000	1600			1,2	-	-
888-E4/0,8	0888 356020 0888 356122	1	light	70-80	80	80-60	60	4	3000	2500	25	0,6	-	0,8	
888-E5/1,0			medium	90-110	90	50-30	40	5	2500	2500			-	1,0	
888-E6/1,2			heavy	120-160	120	25-10	20	5	2000	1600			-	1,2	
888-E7/1,5													-	1,5	
888-E8/1,2	0888 260020 0888 260023 0888 260122 0888 260522	2	light	70-80	80	80-60	60	4	3000	2500	35	0,6	1,2	-	
888-E9/1,6													1,6	-	
888-E10/2,0													2,0	-	
888-E11/1,6					4								1,6	-	
888-E12/2,0			medium	90-110	90	50-30	40	4	2500	2500			2,0	-	
888-E13/2,4								5					2,4	-	
888-E14/2,0			heavy	120-160	120	25-10	20	4	2000	1600			1,2	2,0	-
888-E15/2,4								5						2,4	-
888-E16/3,2								5						3,2	-
888-E17			0888-160020 0888-160023 0888-160122 0888-160522	1	medium	90-110	90	50-30	40	5			2500	2500	25
888-E19	25	0,6									-	-			
888-E34	light	70-80			80	80-60	60	4	3000	2500	35	-	-	-	
888-E35	medium	90-110			90	50-30	40	5	2500	2500	35	-	-	-	
888-E53	heavy	120-160			120	25-10	20	7	2000	1600	25	1,2	-	-	

\* When sewing very thick layers, it is necessary to reduce the sewing speed significantly; at the parallel sewing and trimming too.

Sewing equipment	For classes and subclasses	Number of needles	Sewing category	Needle number		Polyester thread label number		Maximum stitch length		Sewing speed		Top roller diameter	Wheel feed tooth pitch	Seam distance	Trimming distance from the needle
				Scope	Standard	Scope	Standard	Maximum	Standard *	Maximum	Standard *				
				0,01 mm	001mm	-	-	mm	1/min	1/min	mm				
888-E18/1,6	0888-260020 0888-260023 0888-260122	2	medium	90-110	90	50-30	40	4	2500	2500	25	1,2	1,6	-	
888-E20/2,0				90-120	90			5					2,0	-	
888-E21/2,4				90-120	90			5					2,4	-	
888-E30/1,6				90-110	90			4					1,6	-	
888-E50/3,6			heavy	120-160	120	25-10	20	5	2000	1600			35	3,6	-
888-E23	0888-160053 0888-160152	1	light	70-80	80	80-60	60	4	3000	2500	25	0,6	-	-	
888-E24			medium	90-110	90	50-30	40	5	2500	2500			-	-	
888-E25			heavy	120-160	120	25-10	20	7	2000	1600			1,2	-	-
888-E38			light	70-80	80	80-60	60	4	3000	2500	25	-	-	-	
888-E39			medium	90-110	90	50-30	40	5	2500	2500			-	-	
888-E26/0,8	0888-356152	1	light	70-80	80	80-60	60	4	3000	2500	25	0,6	-	0,8	
888-E27/1,0			medium	90-110	90	50-30	40	5	2500	2500			-	1,0	
888-E28/1,2			heavy	120-160	120	25-10	20	5	2000	1600			-	1,2	
888-E29/1,5			-	-	-	-	-	-	-	-			-	1,5	
888E40/0,8			light	70-80	80	80-60	60	4	3000	2500	25	-	-	0,8	
888-E41/1,0			medium	90-110	90	50-30	40	5	2500	2500			-	1,0	
888-E36/0,8	0888-356020 0888-356122	1	light	70-80	80	80-60	60	4	3000	2500	25	-	-	0,8	
888-E37/1,0			medium	90-110	90	50-30	40	5	2500	2500			-	1,0	
888-E44/2,0	0888-460522	2	light	70-80	80	80-60	60	4	3000	2500	35	0,6	2,0	-	
888-E45/2,0			medium	90-120	90	60-30	40	5	2500	2500			2,0	-	
888-E46/2,4				90-120	90	60-30	40	5	2500	2500			2,4	-	
888-E47/2,4			heavy	120-140	120	25-10	20	5	2000	1600			2,4	-	
888-E48/3,2				120-160									1,2	3,2	-
888-E51/1,2			light	70	70	80-60	90	4	3000	2500			0,6	1,2	-
888-E52/1,6				70-80	80						1,6	-			

\* When sewing very thick layers, it is necessary to reduce the sewing speed significantly; at the parallel sewing and trimming too.

Sewing equipment	For classes and subclasses	Number of needles	Sewing category	Needle number		Polyester thread label number		Maximum stitch length	Sewing speed		Top roller diameter	Wheel feed tooth pitch	Seam distance	Trimming distance from the needle
				Scope	Standard	Scope	Standard		Maximum	Standard *				
				0,01 mm	0,01mm	-	-		mm	1/min				
888-E54/2,0	0888-260020 0888-260023 0888-260122	2	medium	90-110	90	60-30	40	4	2500	2500	25	1,2	2,0	-
888-E55/2,0														
888-E56/2,4														
888-E57/2,4														
888-E58/0,8	0888-167020 0888-167122	1	light	70-80	80	80-60	60	3	3000	2500	35	0,6	-	0,8
888-E59/1,0			medium	90-120	100	50-30	40	5	2500	2500			-	1,0
888-E60/1,2			heavy	120-160	130	25-10	20	5	2000	1600			-	1,2
888-E64/0/4	0888-160125	1	light	70-80	80	80-60	60	4	3000	2500	35	0,6	-	-
888-E65/0/5			medium	90-110	100	50-30	40	5	2500	2500			-	-
888-E66/0/5			medium	80-90	90	60-30	40	5	2500	2500			-	-
888-E68	0888-360122	1	light	70-80	80	80-60	60	4	3000	2500	35	0,6	-	-
888-E69			medium	90-110	90	50-30	40	5	2500	2500			-	-
888-E70			heavy	120-160	120	25-10	20	7	2000	1600			1,2	-

\* When sewing very thick layers, it is necessary to reduce the sewing speed significantly; at the parallel sewing and trimming too.

### 3.3 Sewing equipment special





#### Machine with edge trimming

When changing a sewing category, it is also necessary to replace a throat plate insert (it can be bought additionally). At the same time, when the insert is replaced, the edge width of the trimmed material is changed too, so it is necessary to change the lateral setting of the trimming knife (Service manual, section 8.4).

Sewing category 3			
Trimming distance/mm	2,0	2,4	3,0
Maximum stitch length	5		
Maximum sewing speed	2000		
Maximum lifting of standard knife	2,4		
Throat plate	0888 201240		
Throat plate insert	S080 811809	S080 811803	S080 811805
Upper knife	S080 870235 (S080 870238, S080 870239)		

It is possible that it will be necessary to limit the sewing speed (or machine speed) when trimming, dependent on the set stitch length and material to be trimmed, to be able to achieve the required sewing quality.

## Types of trimming knives

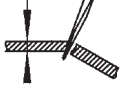
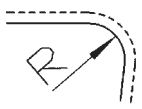
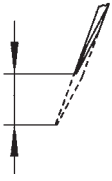
		 SINTERED CARBIDE		
Trimmed material thickness 	1 - 4	1,5 - 4	1 - 2	0,2 - 0,8
Min. radius of trimmed material 	~6	~6	~4	~6
Knife lifting 	2,4	2,4	1,2	2,4

EN

The standard upper knife made of tool steel is marked "A". This type of knife can be also purchased as a type made of sintered carbide for a longer service life. To cut very small radiuses, it is possible to use a knife of the "B" type; and for thin and soft materials it is possible to order the "C" type. With the latter two knives it is necessary to reduce the trimming mechanism lifting (Service manual, section 8.2) to the value given in the table; it is necessary to adjust their correct height again (Service manual, section 8.3).

The supplied knives can be sharpened again after they have gone blunt, either by means of a special manual fixture M269 (may be ordered additionally), or on a bracket of a special grinding machine, observing the prescribed geometry (Service manual, section 8.8).

## 4 Optional equipment

The following optional equipments are available for the class **888**:

Order No.	Optional equipment	Subclasses																		
		888-160020	888-160122	888-260020	888-260122	888-356020	888-356122	888-160152	888-356152	888-460522	888-360122	888-160023	888-260023	888-160053	888-260053	888-260152	888-167020	888-167122	888-160125	
9880 888101	Integrated sewing light 2 LEDs incl. transformer	x	x	x	x	x	x	x	x	x	x	x	x	x	x	x	x	x	x	x
9880 888100	Diode sewing light 3W	x	x	x	x	x	x	x	x	x	x	x	x	x	x	x	x	x	x	x
0888 320254	Variator for continuous regulation of the difference between the feed wheel and the driven top roller		x		x	o	o	x	o	x	x					x		x	x	
0688 130384	Knee lever for the sewing foot lifting	x	x	x	x	x	x	x	x	x	x	x	x	x	x	x	x	x	x	x
9780 000108	WE-8, maintenance unit for the pneum. optional equipment									x										
0797 003031	Pneum. connection kit for the connection of the stand with the maintenance unit									x										
9805 791113	USB-Memory-Stick for data transfer with the EFKA Control DA321G		x		x		x	x	x	x	x					x		x	x	
0867 490010	Bracket for the control panel		x		x		x	x	x	x	x					x				x
0888 331240	Bracket for the control panel																o	o		
9800 330009	Control panel V810		x		x		x	x	x	x	x					x	x	x	x	
9800 330010	Control panel V820		x		x		x	x	x	x	x					x	x	x	x	
0888 310134	Needle feed locking	x	x	x	x								x		x					x
N800 080030	Retractable material guide	x	x	x	x	x	x	x	x	x	x	x	x	x	x	x				x
N800 080004	Retractable roller material guide	x	x	x	x	x	x	x	x	x	x	x	x	x	x	x				x
N800 080001	Retractable material guide	x	x	x	x	x	x	x	x	x	x	x	x	x	x	x				x
0888 220334	Top roller Ø 25 mm knurled	x	x	x	x	x	x	x	x	x	x	x	x	x	x	x	x	x	x	x
0888 220344	Top roller Ø 25 mm smooth	x	x	x	x	x	x	x	x	x	x	x	x	x	x	x	x	x	x	x
0888 220354	Top roller Ø 25 mm rubberized	x	x	x	x	x	x	x	x	x	x	x	x	x	x	x	x	x	x	x
0888 220364	Top roller Ø 35 mm knurled	x	x	x	x	x	x	x	x	x	x	x	x	x	x	x	x	x	x	x
0888 220374	Top roller Ø 35 mm smooth	x	x	x	x	x	x	x	x	x	x	x	x	x	x	x	x	x	x	x
0888 220384	Top roller Ø 35 mm rubberized	x	x	x	x	x	x	x	x	x	x	x	x	x	x	x	x	x	x	x
0888 220394	Top roller Ø 45 mm, width 3,8 mm	x	x	x	x	x	x	x	x	x	x	x	x	x	x	x	x	x	x	x
0888 220404	Top roller Ø 45 mm, width 2,0 mm	x	x	x	x	x	x	x	x	x	x	x	x	x	x	x	x	x	x	x
0688 320520	Wheel feeder 0,6 mm	x	x	x	x	x	x	x	x	x	x	x	x	x	x	x	x	x	x	x
0688 320530	Wheel feeder 1,2 mm	x	x	x	x	x	x	x	x	x	x	x	x	x	x	x	x	x	x	x
0888 200760	Throat plate insert - 0,8 mm					x	x		x											
0888 200770	Throat plate insert - 1,0 mm					x	x		x											
0888 200780	Throat plate insert - 1,2 mm					x	x		x											
0888 200790	Throat plate insert - 1,5 mm					x	x		x											



Obj. číslo	Volitelné vybavení	Podtřídy																	
		888-160020	888-160122	888-260020	888-260122	888-356020	888-356122	888-160152	888-356152	888-460522	888-360122	888-160023	888-260023	888-160053	888-260053	888-260152	888-167020	888-167122	888-160125
9081 300001	Tool kits M-type	x	x	x	x	x	x	x	x	x	x	x	x	x	x	x	x	x	x
0888 150234	Thread monitor 1 needle		x				x				x								x
0888 150544	Thread monitor 2 needles				x					x									
0888 590014	Upgrade kit		x		x			x									x		x
0887 590014	Upgrade kit		x		x		x	x	x	x	x						x		x

### Stands

MG 55 400334	Stand set MG 55-3 for toothed belt drive, with pedal, table top size 1060 x 500 mm	x	x	x	x	x	x	x	x	x	x	x	x	x	x	x	x	x	x
MG55 400324	Stand set MG 55-3 for V-belt drive, with pedal, table top size 1060 x 500 mm	x	x	x	x	x	x	x	x		x	x	x	x	x	x	x	x	x
0700 088804	Table top 1060 x 500 mm	x	x	x	x	x	x	x	x		x	x	x	x	x	x	x	x	x
0700 088802	Table top 1060 x 500 mm	x	x	x	x	x	x	x	x		x	x	x	x	x	x	x	x	x

x = Optional equipment

o = Standard equipment

Additional optional equipments can be requested at our Application Center (APC).

E-Mail: [marketing@duerkopp-adler.com](mailto:marketing@duerkopp-adler.com)

EN

The following optional equipments are available for the class **888-M**:

Order No.	Optional equipment	Subclasses																		
		888-160122-M	888-260122-M	888-356122-M	888-160152-M	888-460522-M	888-360122-M	888-167122-M	888-160125-M											
9880 888104	Integrated sewing light 2 LEDs without transformer	x	x	x	x	x	x	x	x											
9850 001089	Transformer	x	x	x	x	x	x	x	x											
9880 888100	Diode sewing light 3W	x	x	x	x	x	x	x	x											
9880 888103	Diode sewing light 3W without transformer	x	x	x	x	x	x	x	x											
0888 321274	Variator for continuous regulation of the difference between the feed wheel and the driven top roller	x	x	o	x	x	x	x	x											
0688 130384	Knee lever for the sewing foot lifting	x	x	x	x	x	x	x	x											
9780 000108	WE-8, maintenance unit for the pneum. optional equipment						x													
0797 003031	Pneum. connection kit for the connection of the stand with the maintenance unit						x													
9835 901005	USB-Memory-Stick for data transfer with the DAC Classic Control	x	x	x	x	x	x	x	x											
0888 310134	Needle feed locking	x	x						x											
N800 080030	Retractable material guide	x	x	x	x	x	x		x											
N800 080004	Retractable roller material guide	x	x	x	x	x	x		x											
N800 080001	Retractable material guide	x	x	x	x	x	x		x											
0888 220334	Top roller Ø 25 mm knurled	x	x	x	x	x	x	x	x											
0888 220344	Top roller Ø 25 mm smooth	x	x	x	x	x	x	x	x											
0888 220354	Top roller Ø 25 mm rubberized	x	x	x	x	x	x	x	x											
0888 220364	Top roller Ø 35 mm knurled	x	x	x	x	x	x	x	x											
0888 220374	Top roller Ø 35 mm smooth	x	x	x	x	x	x	x	x											
0888 220384	Top roller Ø 35 mm rubberized	x	x	x	x	x	x	x	x											
0888 220394	Top roller Ø 45 mm, width 3,8 mm	x	x	x	x	x	x	x	x											
0888 220404	Top roller Ø 45 mm, width 2,0 mm	x	x	x	x	x	x	x	x											
0688 320520	Wheel feeder 0,6 mm	x	x	x	x	x	x	x	x											
0688 320530	Wheel feeder 1,2 mm	x	x	x	x	x	x	x	x											
0888 200760	Throat plate insert - 0,8 mm			x																
0888 200770	Throat plate insert - 1,0 mm			x																
0888 200780	Throat plate insert - 1,2 mm			x																
0888 200790	Throat plate insert - 1,5 mm			x																
9081 300001	Tool kits M-type	x	x	x	x	x	x	x	x											
0888 331240	Bedienfeld								o											

**Obj. číslo      Volitelné vybavení      Podtřídy**

		888-160122-M	888-260122-M	888-356122-M	888-160152-M	888-460522-M	888-360122-M	888-167122-M	888-160125-M										
0888 150234	Thread monitor 1 needle	x		x			x	x											
0888 150544	Thread monitor 2 needles		x			x													
0888 590014	Upgrade kit	x	x		x				x										
0887 590014	Upgrade kit	x	x	x	x		x	x	x										

**Stands**

MG 55 400334	Stand set MG 55-3 for toothed belt drive, with pedal, table top size 1060 x 500 mm	x	x	x	x	x	x	x	x										
0700 088804	Table top 1060 x 500 mm	x	x	x	x	x	x	x	x										

x = Optional equipment  
o = Standard equipment

Additional optional equipments can be requested at our Application Center (APC).  
E-Mail: [marketing@duerkopp-adler.com](mailto:marketing@duerkopp-adler.com)



## 5 Technical parameters

### Noise emission

Workplace-specific emission value as per DIN EN ISO 10821:

LpA = 78 dB(A); KpA = 0,44 dB (A) at

- Stitch length: 4.0 mm
- Speed: 2400 rpm
- Sewing material: 2-layer Skaj; 1.6mm 900g/m<sup>2</sup> DIN 53352

Stitch type	double lockstitch 301
Needle system	134LR, 134 KCLR, 134, 134 D
Foot lifting with a hand lever	6 mm
Foot lifting with a knee lever or automatically	12 mm
Thread length after trimming	max. 15 mm
Thread length after short trimming	max. 5 mm
Machine head clearance height	300 mm
Machine head clearance width	280 mm
Machine base plate plan dimensions	178 x 518 mm
Table top plan dimensions	1060 x 500 mm
Table top minimum height	740 mm
Table top maximum height	900 mm
Machine height	max. 1630 mm
Maximum input (short-time)	0,8 kW
Weight of stand	30 kg
Weight of motor EFKA DC 1550	10 kg
Weight of machine head with DAC	54 kg
Compressed air feed	6 bar

## 6 Operation

### 6.1 Threading the needle thread

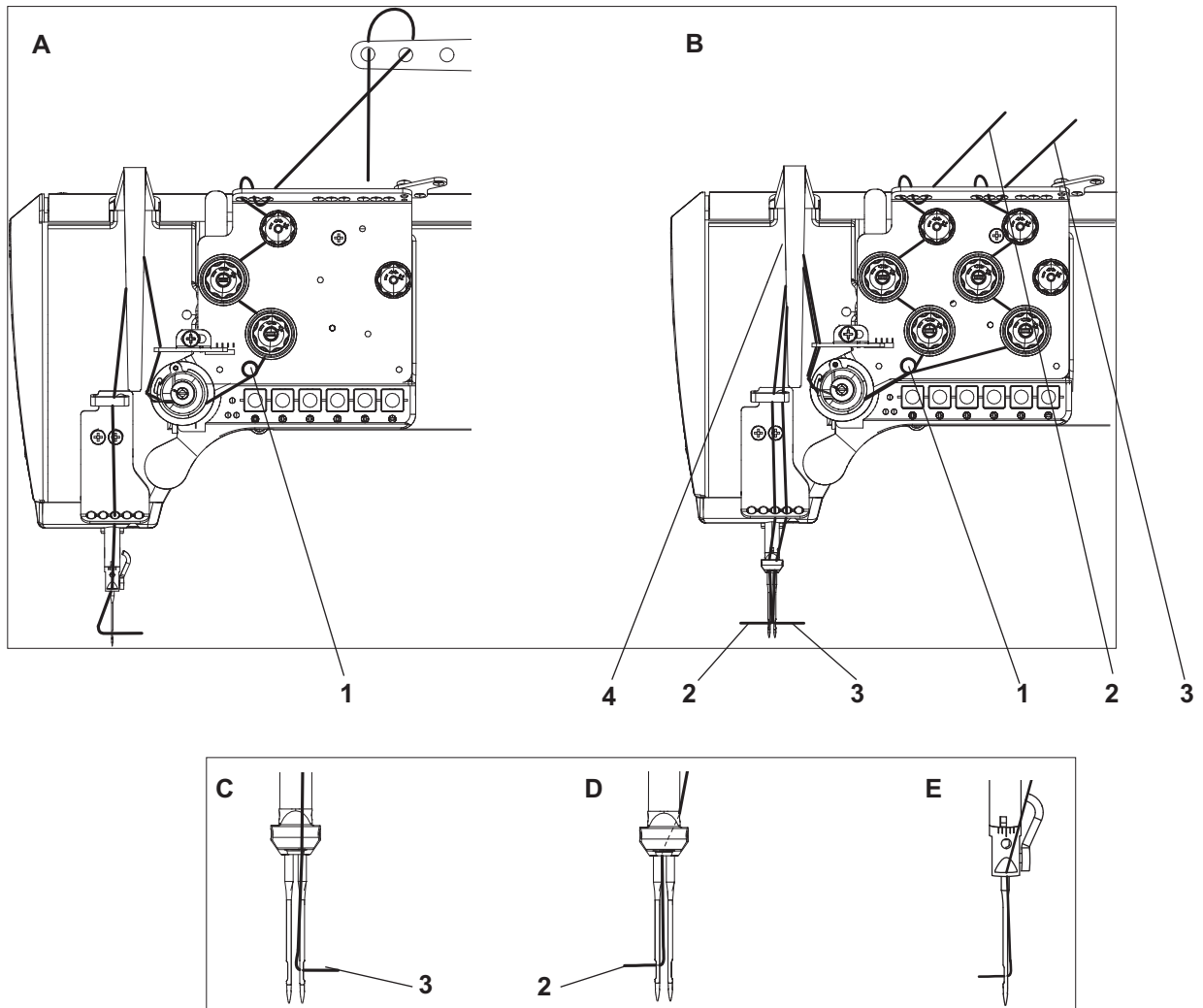

#### Caution! Risk of injury!

Turn off the main switch.

The needle thread may only be threaded with the sewing machine switched off.

- Thread the single needle machine according to fig. (A). If the machine is equipped for heavy sewing, wind the thread around the pin (1).
- Thread the double needle machine according to fig. (B). The thread (2) designed for the left needle is to be threaded in the left tensioners and in the upper hole in the thread lever (4).
- Thread the needles arranged side by side according to fig. (B).
- Thread the diagonally arranged needles according to fig. (C-right needle) and fig. (D-left needle).
- Thread the machine with an edge trimming mechanism according to the fig. (E).
- If the machine is equipped for heavy sewing, wind the threads around the pin (1).

## 6.2 Winding the hook thread

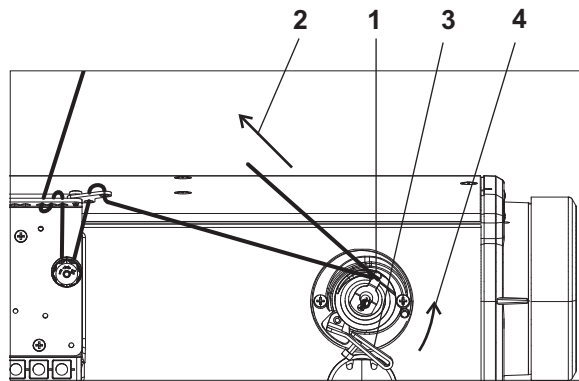

- Thread the thread according to the picture.
- Insert the thread under the knife (1) and tear off by pulling in the arrow direction (2).
- Fix the bobbin and press the lever (3) in the direction (4).
- Start the machine up.
- After the thread winding, slide the thread under the knife again (1) and tear it off.
- Insert another bobbin immediately and press the lever (3).

## 6.3 Inserting the bobbin and threading the hook thread

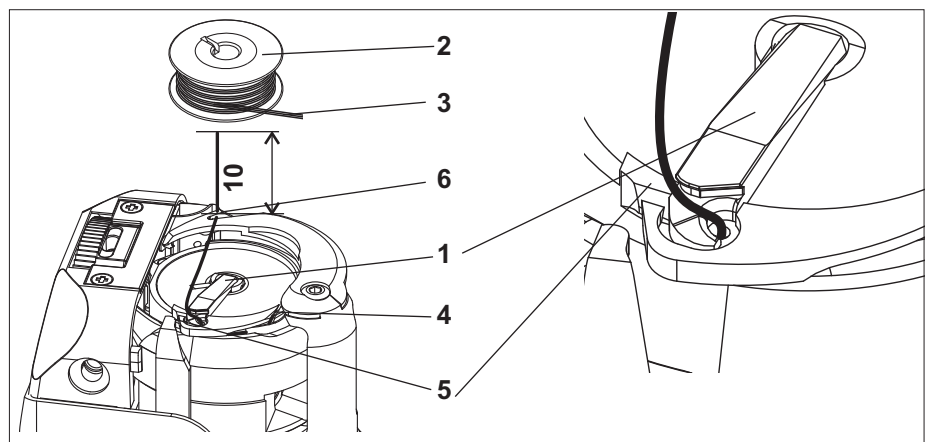

### **Caution! Risk of injury!**

Switch the main switch off and wait till the motor stops.

- Tilt the shutter (1) up.
- Insert the bobbin (2) with the thread end (3) oriented according to the picture.
- Thread the thread through the slit (4) and space (5), hook upon the shutter (1) and fasten it under the spring (6).
- Trim the thread ends according to the picture.
- If the hook is located to the left of the needle, fix the bobbin and do the threading in a similar way.

## 6.4 Adjusting the thread tension

### 6.4.1 Adjusting the hook thread tension

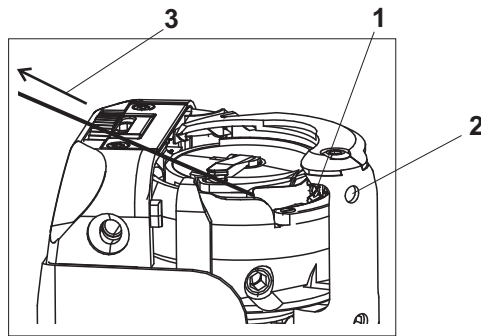

#### Caution! Risk of injury!

Turn off the main switch.

The hook thread tension may only be adjusted with the machine switched off.

- Adjust the hook thread tension via the screw (1). Insert a screwdriver through the hole (2). Increase the tension by tightening the screw.
- Measure the thread tension with a dynamometer. Thread the thread according to the picture and pull in the arrow direction (3). This tension is adjusted in the factory in dependence on the selected sewing equipment according to the table below, and it is suitable for the usual sewing operations. For sewing thin soft materials, it is necessary to reduce the tension. If the seam is to be tightened strongly, it is necessary to increase the tension and reduce the sewing speed at the same time.
- Thread tension of the hook located to the left of the needle is adjusted and measured in a similar way. For this hook, the tension is set up by 10 - 20 % lower than for the hook on the right.

EN

Hook thread tension mean value

Sewing category	Used needle-Number	Thread tension in grams
light	70 - 80	50
medium	90 - 110	65
heavy	120 - 160	90

## 6.4.2 Adjusting the needle thread tension

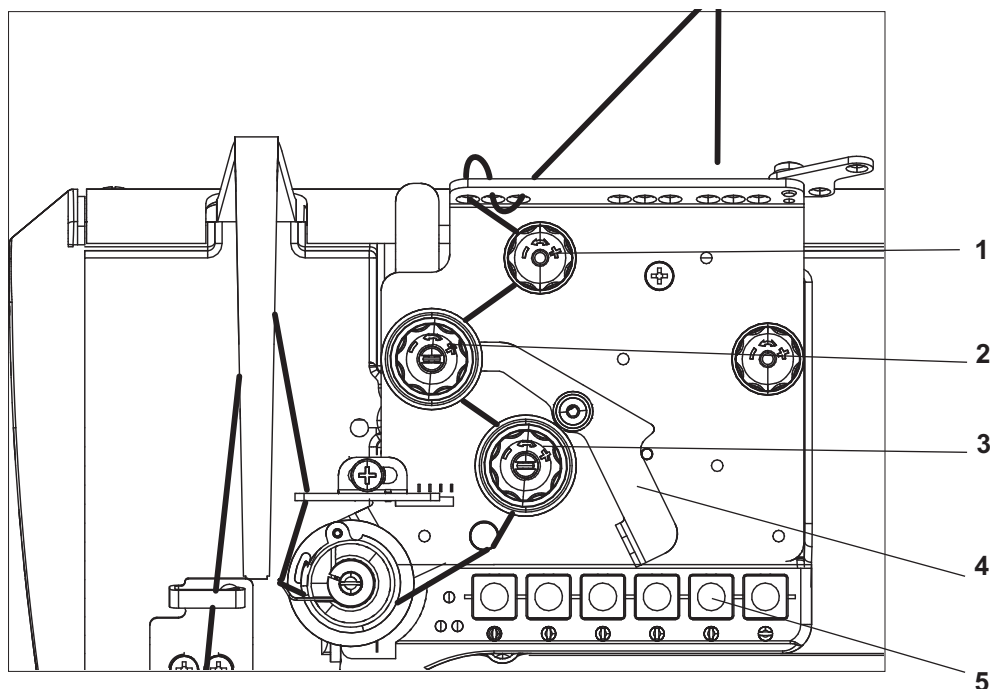

### **Adjusting the pre-tensioner (1)**

- Adjust the supplementary tensioner (1) so that it has the lowest tension possible, but so high that, when taking out the sewn material after the preceding trimming (when the tensioners (2) and (3) are switched off), the thread is not pulled out of the tensioner (1). (Tensioner (1) is not switched off at the foot lifting).

### **Adjusting tensioners (2) and (3)**

#### **ECO and CLASSIC machines with electro-magnetic control**

- The machine can be equipped with a lever (4) for the tensioner (2) temporary switching off. In this case, two thread tension values can be pre-selected and a good stitch tightening can be achieved when sewing over a variable number of layers of the sewn material with one seam.
- Switch the tensioner off (2) with the lever (4) and sew on a smaller number of layers.
- Regulate the thread tension with the tensioner (3), till a good thread loop is achieved (see below).
- Switch the tensioner on (2) by the lever (4) shifting out and sew on a greater number of layers.
- Regulate the thread tension with a tensioner (2), till a good thread loop is achieved (see below).
- If the machine is not equipped with the lever (4), regulate the tension by both tensioners (2) and (3) at the same time so that their nuts are screwed approximately in the same height.



## Adjusting tensioners (2) and (3)

### *CLASSIC machines with pneumatic control*

Through pressing the key (5) the additional tension (2) will be switched off. If the key (5) is pressed anew, the additional tension will be activated again. The connectable additional tension (2) helps in quick adjustment of the needle thread tension, for example in order to get a tight stitch formation with regular seams when sewing different materials.

- Press the key (5).
- Sew material with few layers and regulate the thread tension via the main tensioner (3) until the correct interlacing of the thread is reached (see illustration).
- Sew material with more layers, switch on the additional tension (2) via the key (5) and regulate it until the correct interlacing of the thread is reached.

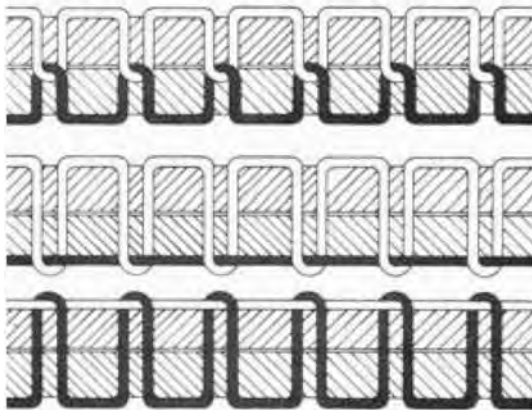

Correct interlacing of threads in the center of the material

Needle-thread tension too weak  
**or**  
Hook-thread tension too strong

Needle-thread tension too strong  
**or**  
Hook-thread tension too weak

## 6.5 Switching on/off the thread tensioners

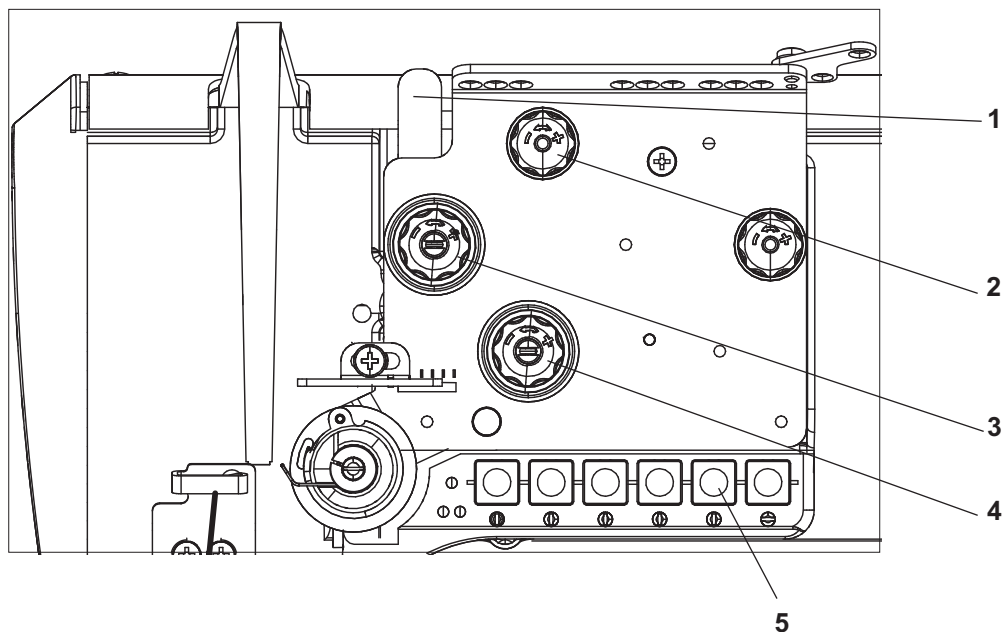

### ***ECO and CLASSIC machines with electro-magnetic control***

- When pulling the hand lever (1) towards the operator, the tensioners (3) and (4) are switched off.
- Tensioner (2) is never switched off.

### ***Manually controlled machines (without thread trimming)***

- Tensioners (3) and (4) are mechanically switched off when the foot is lifted with a hand or knee lever.

### ***Machines with thread trimming***

- Tensioners (3) and (4) are switched off with an electric magnet or pneumatic cylinder at the foot automatic lifting. If the automatic foot lifting at the machine stop is pre-selected, the tensioners are switched off, but temporarily only, so that the switching off electric magnet does not overheat.
- Tensioners (3) and (4) are also switched off temporarily during the trimming cycle.
- Tensioners (3) and (4) are not switched off at the foot lifting with the hand or knee lever.

## 6.6 Adjusting the thread regulator

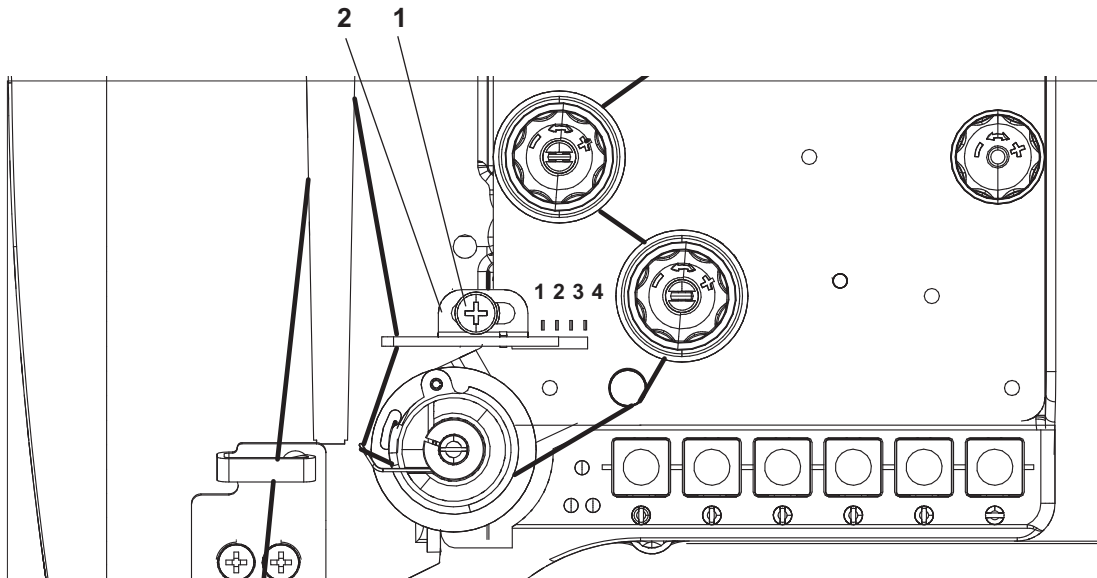

The thread regulator (2) controls the quantity of needle thread required for stitch formation.

The thread regulator must be precisely adjusted for an optimum result.

- Loosen the screw (1), shift the thread regulator (2), and tighten the screw (1).
- For most of the sewing operations, the thread regulator optimal setting is with its right edge set to '2'.
- The setting '3' is suitable for thin materials and very short stitches only

EN

## 6.7 Changing the needle with single-needle machines with the hook on the right

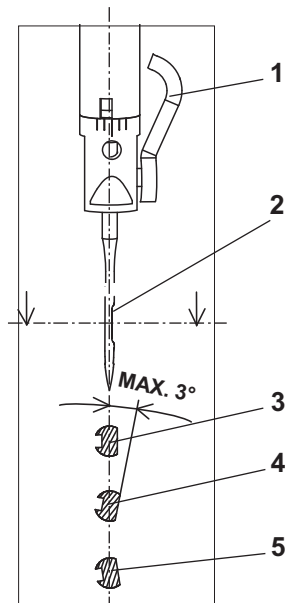

### Caution! Risk of injury!

Replace the needle with the main switch switched off and the motor stopped.

- Draw the lever (1) in your direction to loosen the screw fixing the needle.
- Remove the needle and insert a new one with the needle scarf (2) to the right [see section (3) or (4)]. The needle may not be oriented as shown at section (5).
- Turn the lever back to tighten the screw fixing the needle.



### Caution! Danger of breakage!

A false orientation of the needle may damage the hook point. When changing to another needle size, the distance between hook and needle, as well as the position of the throat plate towards its post must be readjusted (see service instructions).

## 6.8 Changing the needle with single-needle machines with the hook on the left (machine with lower material trimming)

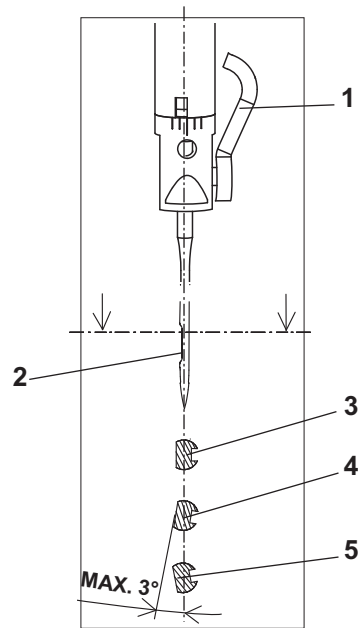

### Caution! Risk of injury!

Turn off the main switch.

The needle may only be changed with the sewing machine switched off

- Draw the lever (1) in your direction to loosen the screw fixing the needle.
- Remove the needle and insert a new one with the needle scarf (2) to the left [see section (3) or (4)]. The needle may not be oriented as shown at section (5).
- Turn the lever (1) back to tighten the screw fixing the needle.



### Caution! Danger of breakage!

A false orientation of the needle may damage the hook point.

When changing to another needle size, the distance between hook and needle, as well as the position of the throat plate towards its post must be readjusted (see service instructions)

## 6.9 Changing the needle with double-needle machines

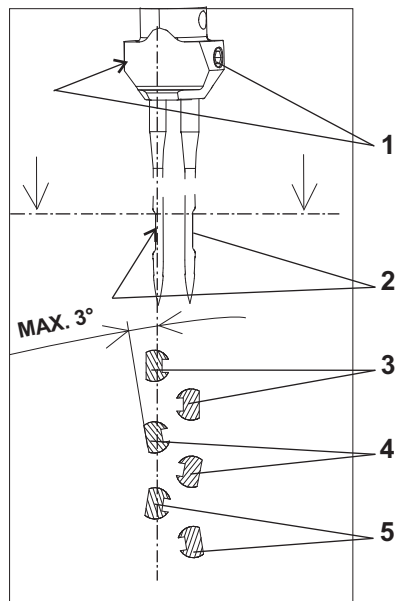

### Caution! Risk of injury!

Turn off the main switch.  
The needles may only be changed with the sewing machine switched off.

- Loosen the screws (1).
- Remove the needle and insert new ones with the needle scarf (2) oriented as shown above [see section (3) or (4)]. The needles may not be oriented as shown at section (5).
- Tighten the screws (1).



### Caution! Danger of breakage!

A false orientation of the needle may damage the hook point.  
When changing to another needle size, the distance between hook and needle, as well as the position of the throat plate towards its post must be readjusted (see service instructions).

## 6.10 Lifting and folding the roller presser

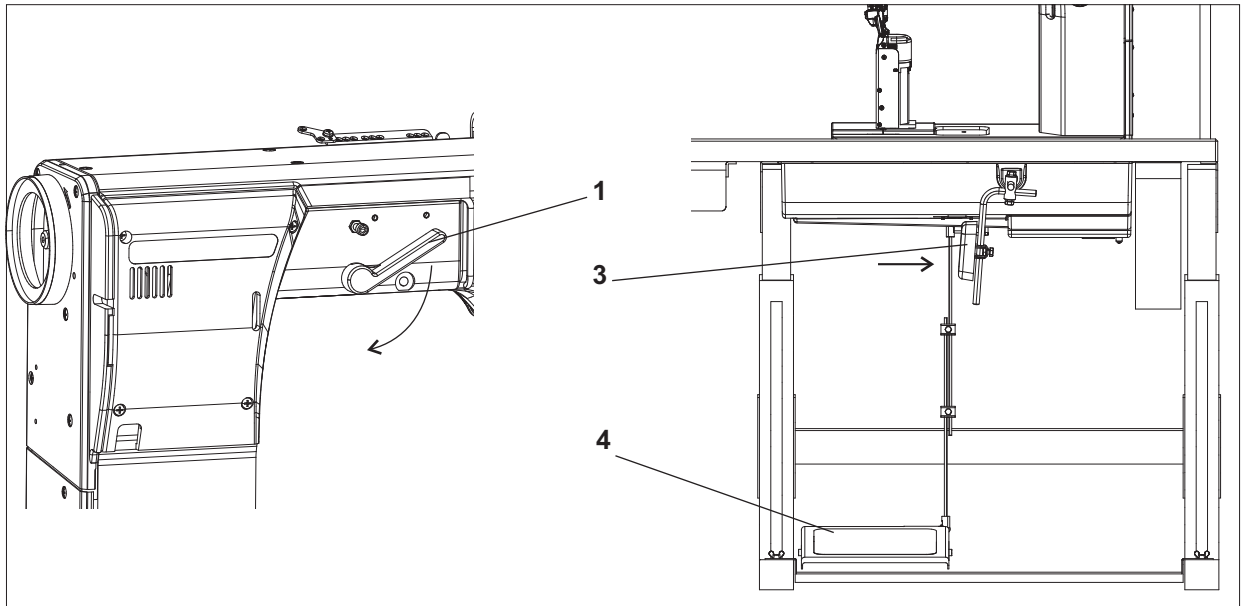

### **Lifting the roller presser with a hand lever**

- Lift the roller presser by the lever turning (1) in the arrow direction to the stop (the roller presser remains lifted, the lever (1) remains tilted).
- Lower the roller presser by putting the lever (1) to the initial position, or by pressing the knee lever (3) and its subsequent release.
- After the roller presser lifting with the hand lever, the machine may be started up (e.g. for hook thread winding).

### **Roller presser lifting with the knee lever**

- The roller presser is lifted by pressing the lever (3); the roller presser is lowered at the lever release.



### **Caution!**

At the roller presser lifting higher than 6 mm over the throat plate the machine may not operate, otherwise the needle bar with the needle holder hits the roller presser, or the needle guides of the double needle machines.

### **Roller presser lifting with a pedal - automatically**

- The roller presser lifting in the machines equipped with a positioning motor (drive) can be controlled by the pedal (4) treading in the position -1 (see chap. 6.16.1). The roller presser is lifted to the upper dead point by means of an integrated electric magnet or pneumatic cylinder. After the pedal is released, the roller presser is lowered.
- It is possible to pre-select the automatic roller presser lifting at each machine stop without the necessity to tread the pedal in the position to the position -1.  
In this case, the roller presser is lowered at the pedal treading in the position +1. After the finishing of the seam, the roller presser remains lifted permanently (see chapter 8).

## Roller presser folding

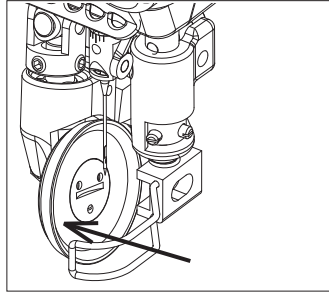

### Caution! Risk of injury!

Roller presser folding to be done at main switch off and standing motor.

- Lift the roller presser with the hand lever.
- Lift the roller presser by pressing in the signed direction.

## 6.11 Sewing-foot pressure

### 6.11.1 Setting through the setting wheel

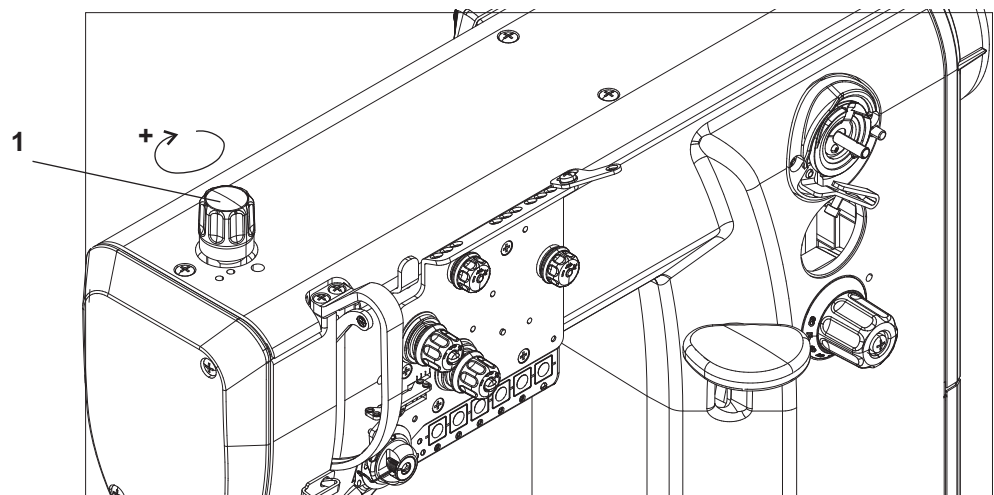

- The required sewing-foot (roller) pressure is set with the setting wheel (1).
- To increase the roller pressure = turn the setting wheel (1) clockwise.  
To decrease the roller pressure = turn the setting wheel (1) anti-clockwise.
- The roller pressure is to be as small as possible, but strong enough so that the roller presser is not lifted by the needle friction in the material during the upward movement and that the feeding is reliable.
- The maximum roller presser pressure is 100 N in the machine equipped with solenoid, and 160 N in the machine with the pneumatic cylinders.



### 6.11.2 Constant sewing-foot pressure through the cylinder

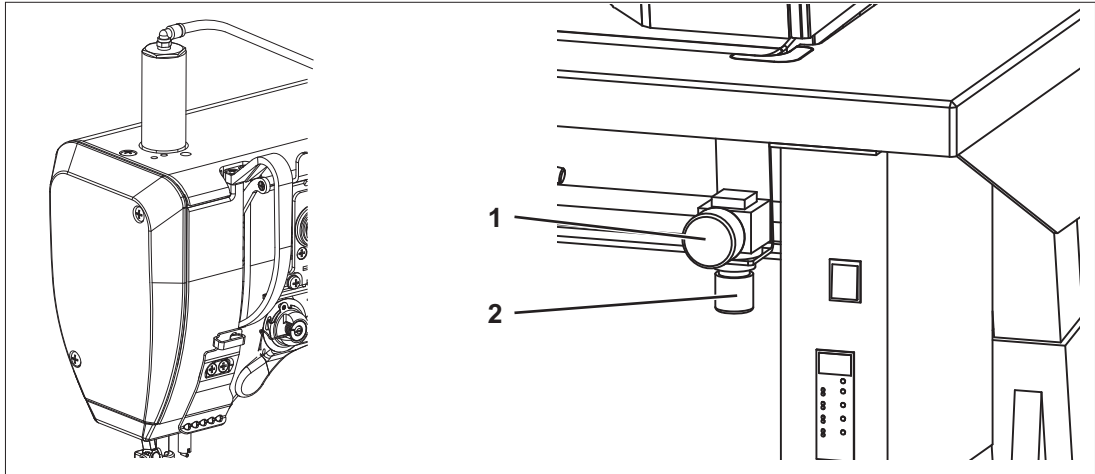

- The pressure of the roller presser will be set via the setting wheel (2).
- Pull the handle (2) downwards and turn it until the desired operating pressure is shown on the manometer (1).

### 6.12 Sewing backward (backtacking)

EN

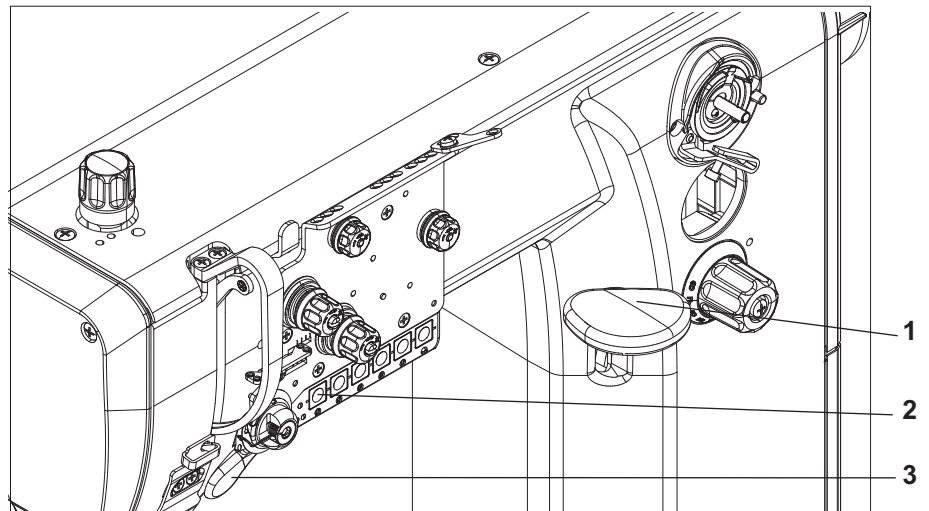

#### **Backtacking with the lever**

- Push the stitch regulator lever (1) downwards.  
The machine sews backward stitches as long as the stitch regulator lever (1) is being pushed.

#### **Backtacking with the key-** depending on the type of key panel

- Press the key (2) or (3). The machine sews backward stitches as long as the key (2) or (3) is being pressed.

#### **Automatic backtacking (bartacking)**

In the machines equipped with the positioning motor it is possible to pre-select the backtacking by a pre-selected backstitches number both at the beginning and at the seam end. At the seam beginning (after the preceding thread trimming) after the pedal treading forwards the machine sews the pre-selected bartack entirely automatically. The same at the seam end after the pedal treading in the position -2 the machine sews the pre-selected end bartack and then trims the threads (see chapter 8).

## 6.13 Setting the stitch length

### *ECO and CLASSIC Machines with electro-magnetic control*

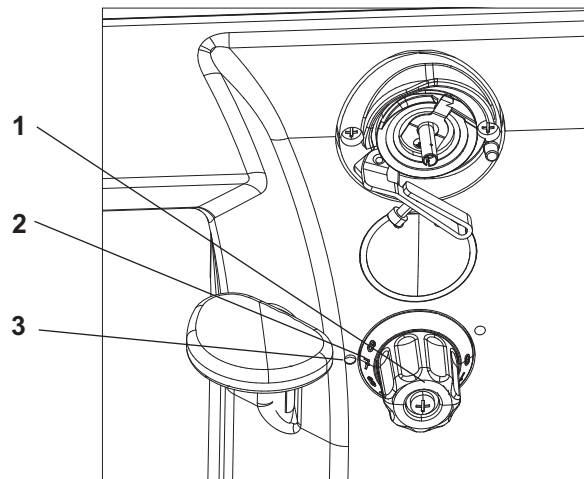

- Turn the setting wheel (1) so that the number (2) indicating the required stitch length in mm corresponds to the mark (3).

### *CLASSIC machines with pneumatic control*

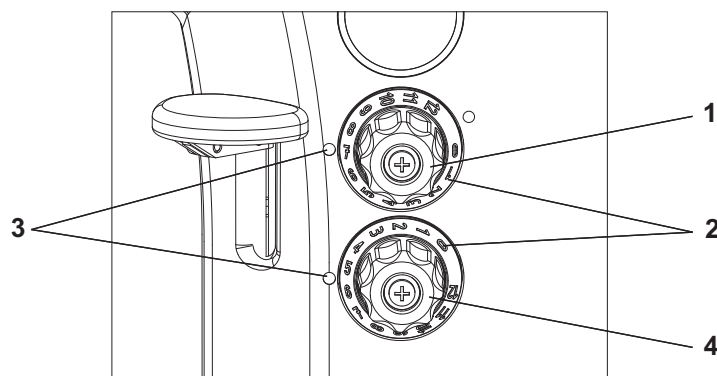

The special sewing machine 888 is equipped with two setting wheels. Thus, two different stitch lengths can be sewn, that are activated by actuating a key during the sewing process.

The two stitch lengths are set with the setting wheels (1) and (4) on the machine arm.

- Set the bigger stitch length with the upper setting wheel (1). Turn the setting wheel (1) so that the number (2) indicating the required stitch length in mm is opposite the mark (3).
- Set the smaller stitch length with the lower setting wheel (4). Turn the setting wheel (4) so that the number (2) indicating the required stitch length in mm is opposite the mark (3).
- The stitch length are the same for both, forward and backward sewing.



#### **CAUTION Danger of breakage!**

The stitch length set with the lower setting wheel (4) must not exceed the stitch length set with the upper setting wheel (1).

#### **Hint**

In order to facilitate the setting of stitch lengths, the stitch length that remains unchanged should be activated with key (4) see chapter 6.15.2; 6.15.3.

## 6.14 Switching on the safety clutch at the hook blocking

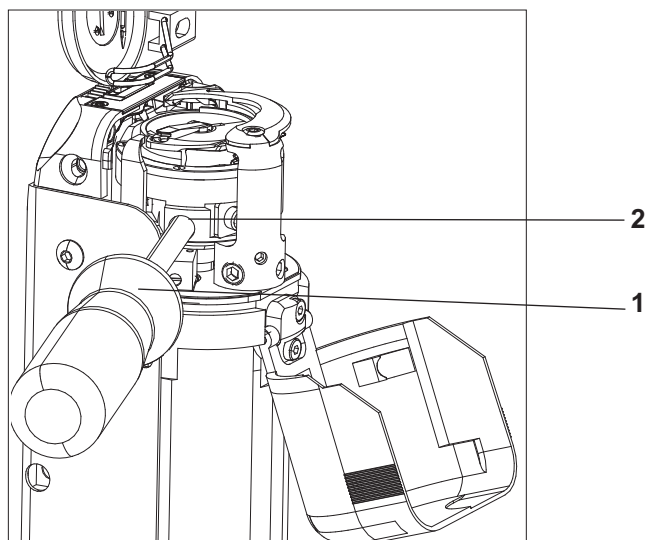

- If the thread gets in the hook way, the hook gets blocked and it is subsequently disconnected from the motor by the safety clutch.



### **Caution! Risk of injury!**

Turn off the main switch.  
Switch the safety clutch on, with the sewing machine switched off.

EN

- Turn the hand wheel until you hear a switching click (snapping) of the safety clutch.
- Turn the hand wheel in the opposite direction until the hook gets released.
- If the safety clutch remains switched off accidentally, insert a screwdriver (1) in the hole (2) and turn the hand wheel until the safety clutch gets switched.
- Release the blocked hook (remove fault).

## 6.15 Controlling the machine equipped with a positioning motor

### 6.15.1 Using the pedal

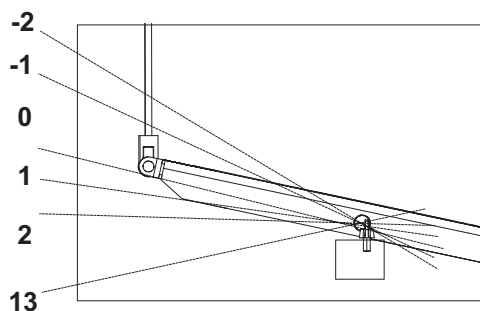

The pedal position is scanned by a sensor distinguishing 16 levels. The meaning is given in the table:

Pedal position	Pedal motion	Meaning
-2	Over heel fully backwards	Command for thread trimming (seam finishing)
-1	Over heel slightly backwards	Command for foot lifting
0	Neutral position	See notes
1	Slightly forwards	Command for foot lowering
2	Further forwards	Sewing at minimum speed (1. speed gear)
3	Further forwards	Sewing - 2. speed gear
:	:	:
13	Fully forwards	Sewing at maximum speed (12. speed gear)

**Note:**

In addition to the neutral position, it is possible to pre-select the needle position (down/up) and the foot position (down/up) at the stopping in the seam (by the pedal positioning in the neutral position), the foot position (down/up) after the seam finishing (by the pedal treading fully backwards and positioning the pedal in the neutral position).

## 6.15.2 By the key panel 9880 867101

The function of the keys on the keypad depends on the type of the drive used and on the sewing machine equipment. Generally, the functions of the keys and the related symbols (pictograms) under the keys may be changed, but the particular drive must support the required function. Detailed information about the function setting is included in the Operating manual and Parameter sheets of the DAC/Efka drives.

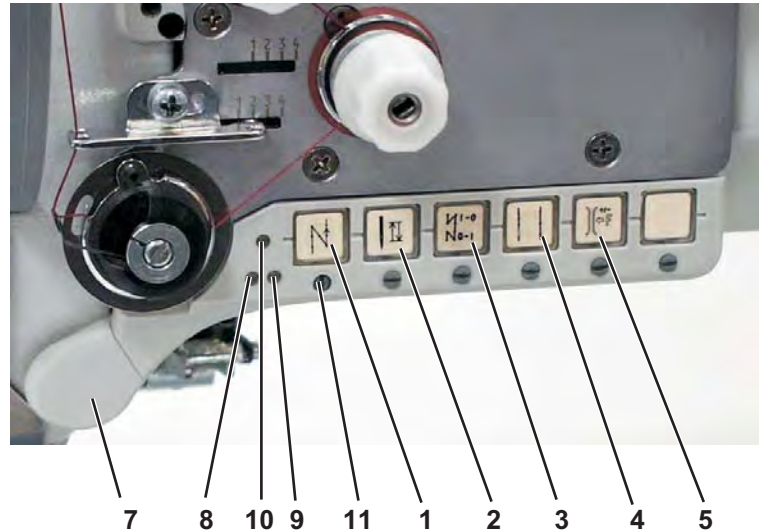

The below table shows an example of typical factory-arranged key pads:

Key	Function
1	<b>Manual sewing backward</b> The machine sews backward stitches as long as the key is being pushed.
2	<b>Needle positioning to the upper or lower position</b> By parameter <b>F-242</b> (DA321) the following key functions can be defined: 1 = needle up/down 2 = needle up 3 = one stitch (factory setting is 1) The key function for a DAC drive is defined by parameter <b>t5122</b> .
3	<b>Calling out/cancellation of the start or end bartack</b> If the start and end bartack are switched on, the following bartack is switched off by pressing the pushbutton. If the start and end bartack are switched off, the following bartack is switched on by pressing the pushbutton.
4	<b>Switching the stitch length</b> The function of the key can be defined via parameter <b>F-250</b> (DA321). 1 = by pressing the key, the stitch length can be switched between two values set in advance 4 = by pressing the key, the stitch length can be changed in a smaller value, a stitch will be sewn and the machine will be switched over to its original (greater) stitch length. The key function for a DAC drive is defined by parameter <b>t5123</b> .
5	<b>Switching on/off the supplementary thread tension</b> - only CLASSIC machines with pneumatic control If the key is lit up: Supplementary thread tension is switched on (tension discs closed). If the key is not lit up: Supplementary thread tension is switched off (tension discs closed).

LED	Function
<b>8 and 9</b>	Display for empty bobbin with machines equipped with residual thread monitor (left/right bobbin).
<b>10</b>	LED display "power on"
Example of arresting pins: e.g. 11	Through the arresting of the pin <b>11</b> under the key <b>1</b> it is possible to transfer the key <b>1</b> function to key <b>7</b> : - select the function (e. g. <b>1</b> = manual backtacking) - turn the pin <b>11</b> under the key <b>1</b> by 90° clockwise (the groove is vertical) The manual backtacking function can be called out by the key <b>1</b> and <b>7</b> now.



Warning!

Before key (7) can be programmed with a new function, the former setting must be deactivated.

### 6.15.2 By the key panel 9880 888102

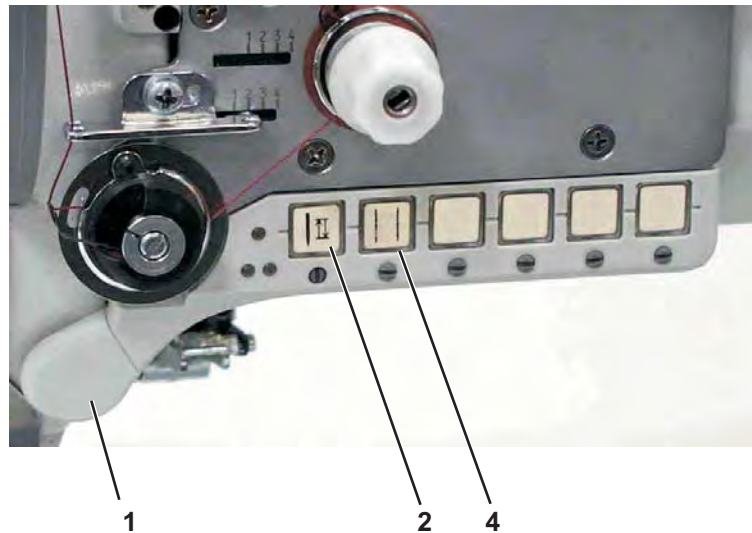

Key	Function
<b>1</b>	<b>Manual sewing backward</b> The machine sews backward stitches as long as the key is being pushed.
<b>2</b>	<b>Needle positioning to the upper or lower position</b> By parameter <b>F-242</b> (DA321) the following key functions can be defined: 1 = needle up/down 2 = needle up 3 = one stitch (factory setting is 1) The key function for a DAC drive is defined by parameter <b>t5122</b> .
<b>4*</b>	<b>Reduce of length stitch</b> - only if the machine is equipped this function By pressing the key the stitch length set advance can be changed in half value, a stitch will be sewn and the machine will be switched over to its original (greater) stitch length.

\* The key can also be matched with a different symbol (e. g. bartack initiation/cancellation).

## 6.16 Lower edge trimming control

### 6.16.1 Switching on/off edge trimmer

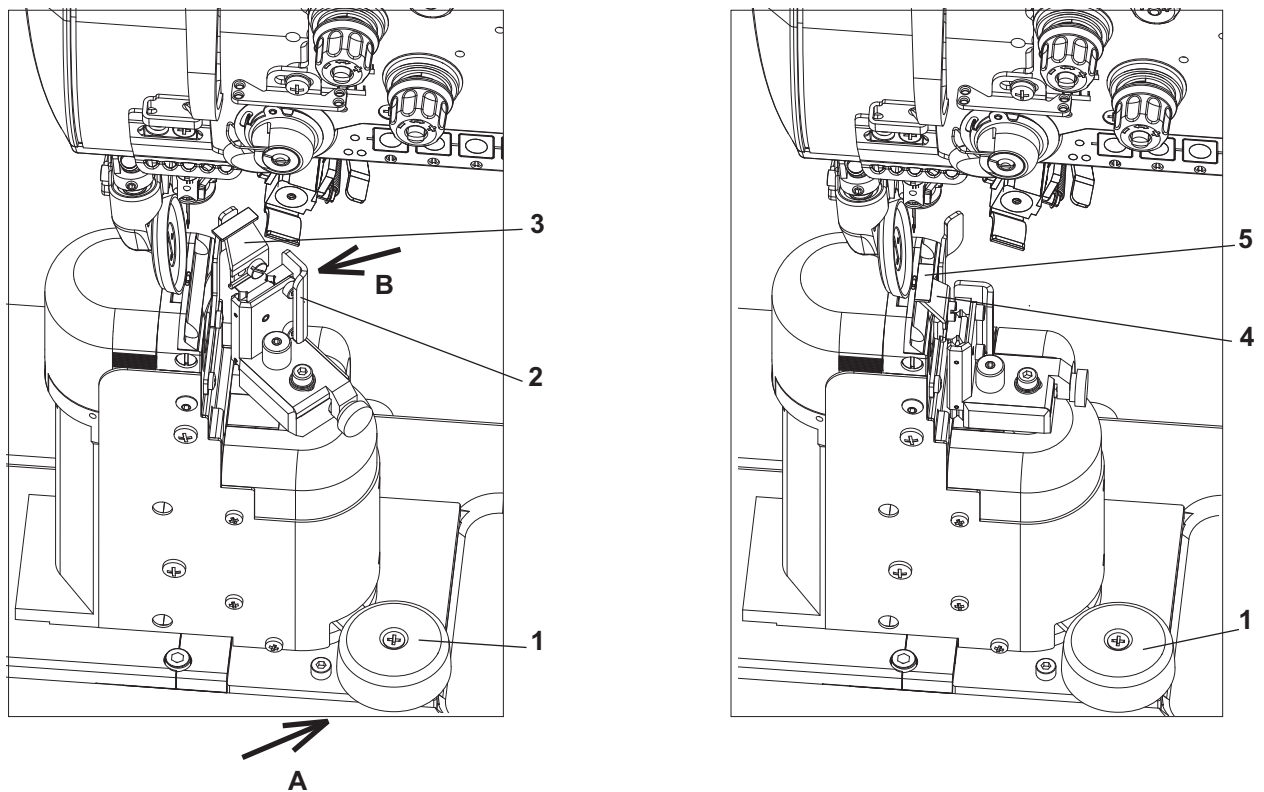

EN

#### Switch on

- Push the knob (1) in the arrow (A) direction, or pull the handle (2) in the arrow (B) direction until the trimming knife gets from the initial position (3) to the switch on position (4).
- Trimming mechanism drive starts up automatically when switched on, and the trimming knife starts oscillating. The mechanism is ready to trim (e.g. a lining) simultaneously with stitching.
- When trimming the edge, direct the trimmed material under the knife collar (5).

#### Switch off

- Push the knob (1) downwards. The trimming knife turns from the switched on position (4) to the initial position (3) and the trimming mechanism drive switches off automatically.

*Setting: see Service instructions*

## 6.16.2 Switching on/off material guide

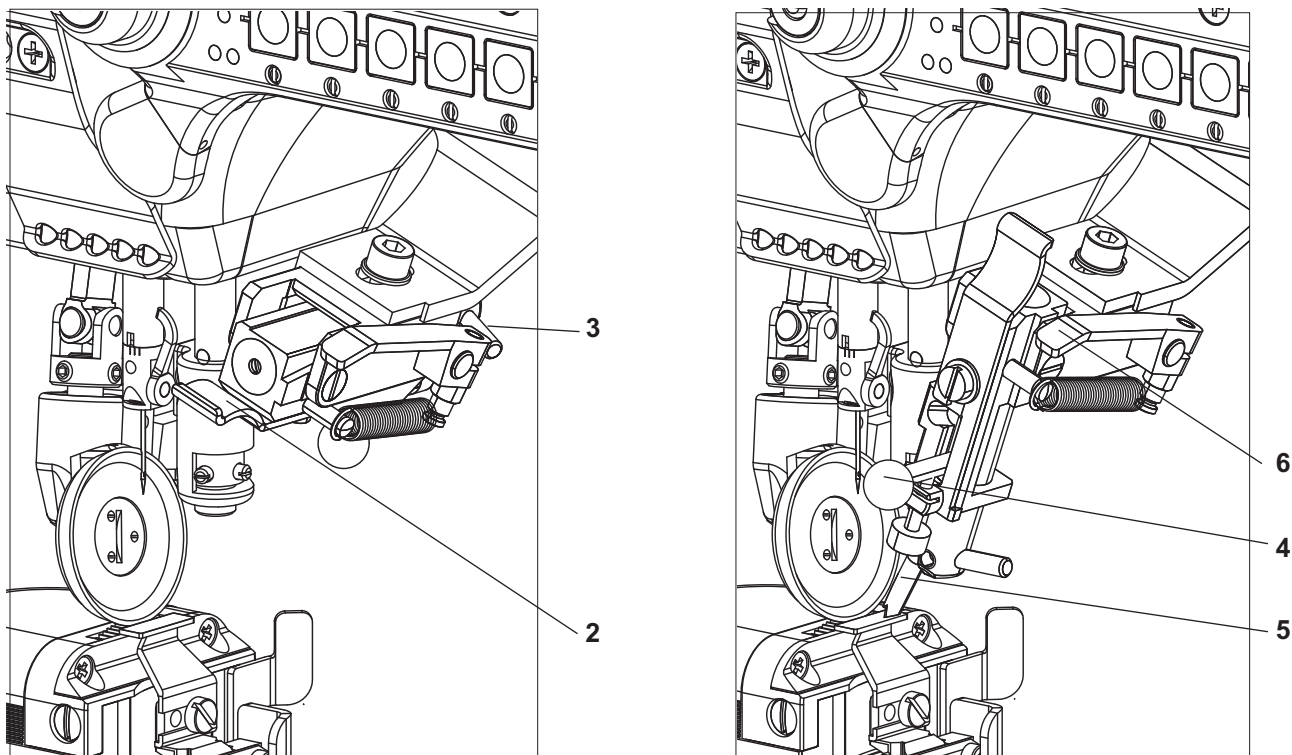

### Switch on

- Put the guide in a working position by pushing the lever (2) upwards or by pulling the guide body (3) downwards.

### Switch off

- Shift the ball (4) upwards and to the left. The guide element (5) lifts in a setting position. When returning the guide element (5) in the working position, proceed in a reverse order.
- Or push the lever (6) downwards and the spring will turn the whole guide in the setting position.



### 6.16.3 Material guide adjustment

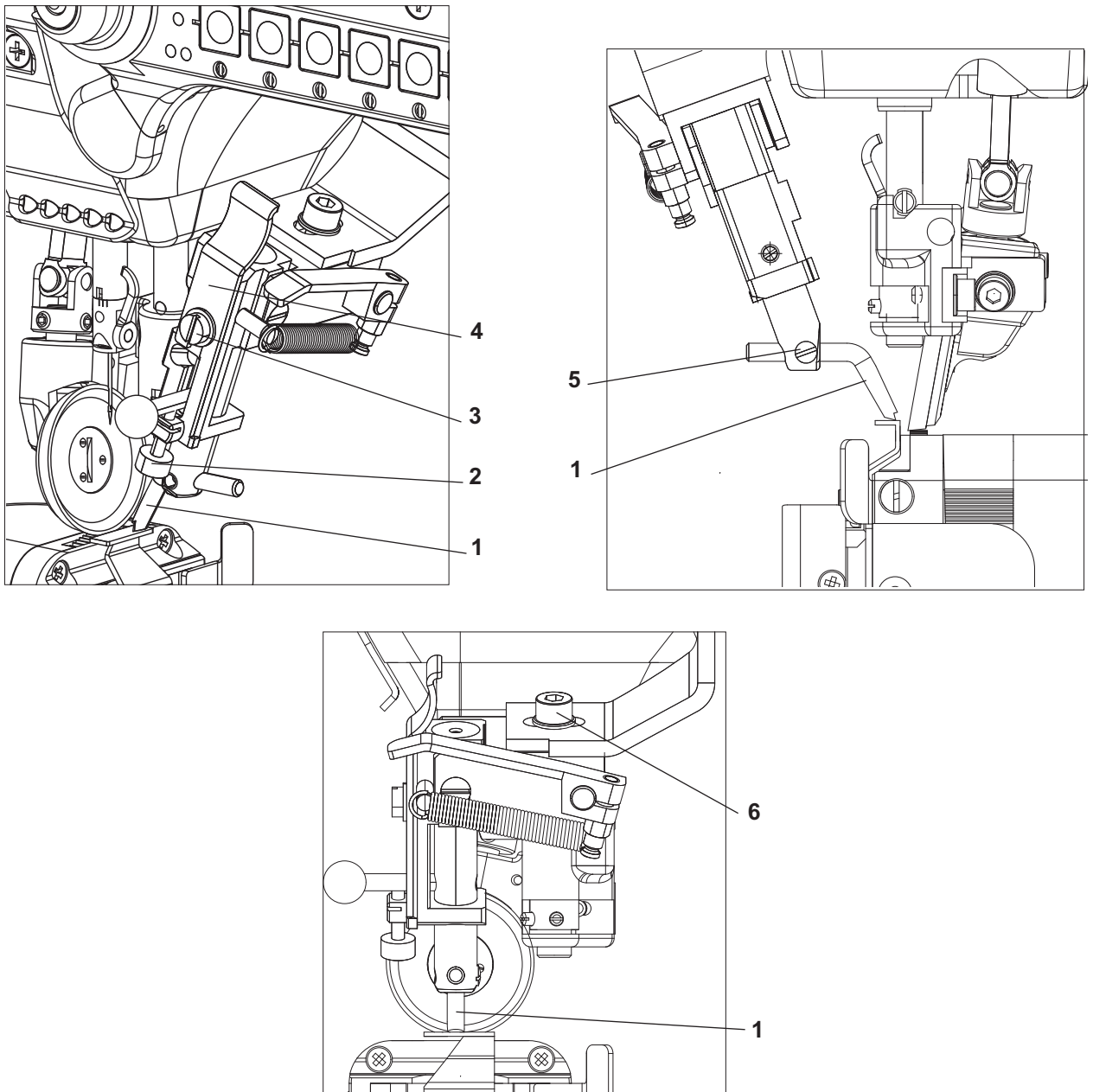

EN

- Adjust the guide element (1) height with a bolt (2). The guide element is lifted, when tightening the bolt, and vice versa. If the bolt (2) strikes the end of the adjustment range, the latter can be widened by the bolt (3), loosening the plate (4) shifting to a different position and its repeated fixing.
- Adjust the lateral position of the guide element (1) by the bolt loosening (5), the element shifting, and its repeated fixing.
- Adjust the guide position in the sewing direction after loosening the bolt (6). The rear edge of the guide element (1) should be located in the needle hole center. After adjustment, tighten the bolt (6).

## 6.17 Upper oblique edge trimming control

### 6.17.1 Switching on/off edge trimmer



#### **Caution: Risk of injury!**

Adjust the edge trimmer mechanism only with the sewing machine switched off.

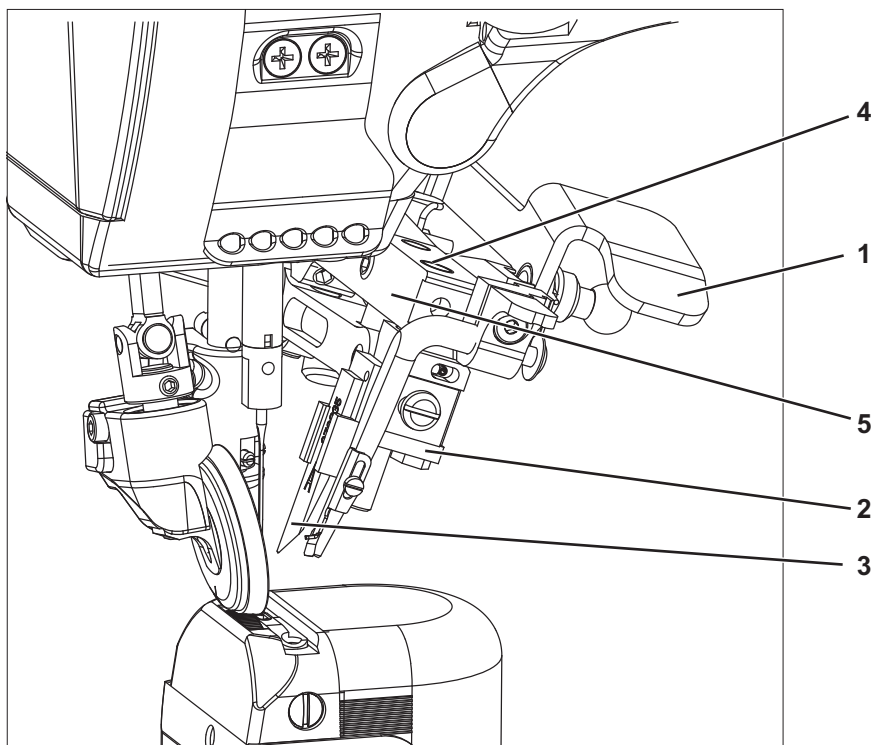

#### **Switch on**

- Push the lever (1) down.
- By this action the upper knife holder (2) together with the trimming knife (3) is shifted to the bottom cutting position.  
According to the standard parameter setting, the knife driven by an electric motor vibrates only at the pedal treading down to set the sewing machine in operation

#### **Switch off**

- Return the lever (1) to top position.



To provide a faultless function, it is needed to fill in several drops of lubrication in the felt lubrication spot (4) on the main holder of the trimming edge (5) once a week.

*Setting: see Service instructions*

## 6.17.2 Material guide adjustment

For a correct guiding of the sewn material against the trimming knife a tipping guide can be used.

The guide can be lowered in the bottom position independent of the trimming knife holder by pushing down of the control lever (1). Another possibility is to switch the guide on and off simultaneously with the switching on the edge trimmer main lever (2), which is ensured by pushing down of the pin (3) in the upper (switched off) position of both levers.

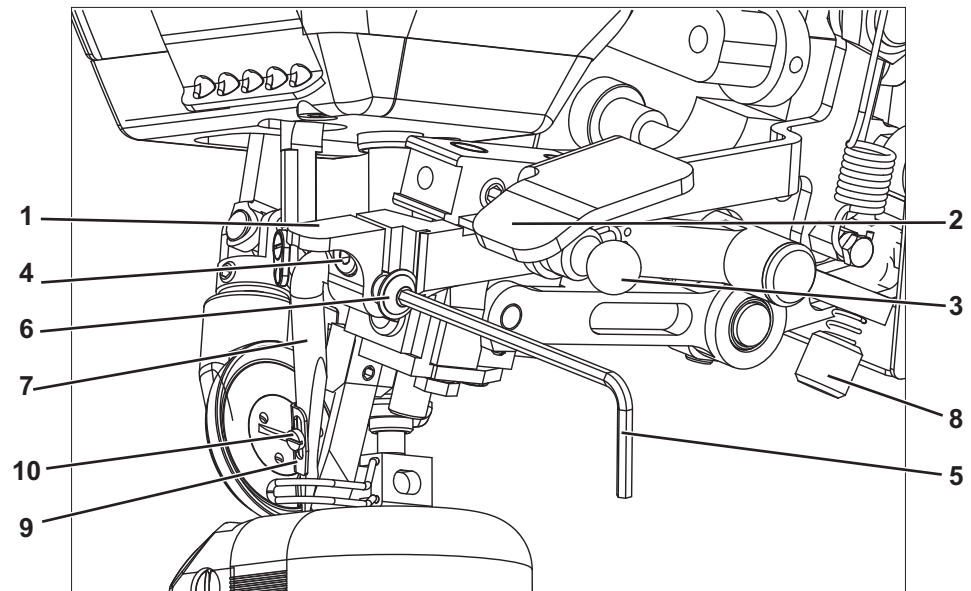

- With the lowered control lever (1), slightly loosen the bolt (4) and with an Allen key (5) turn the bolt (6) to achieve the required lateral position towards the trimming knife.
- At the same time it is necessary to set the position of the guide (7) in the sewing direction by its turning in the lever (1).
- Set the suitable height of the guide over the throat plate by turning of the setting bolt (8).
- After adjusting the guide, tighten the fixing bolt (4).

For better guiding of the sewn material it is possible to use a retaining part (9) attached to the guide (7), the height of which can be set up after the fixing bolt (10) loosening.

## 6.18 Disengaging the needle bar with subclass 888-460522

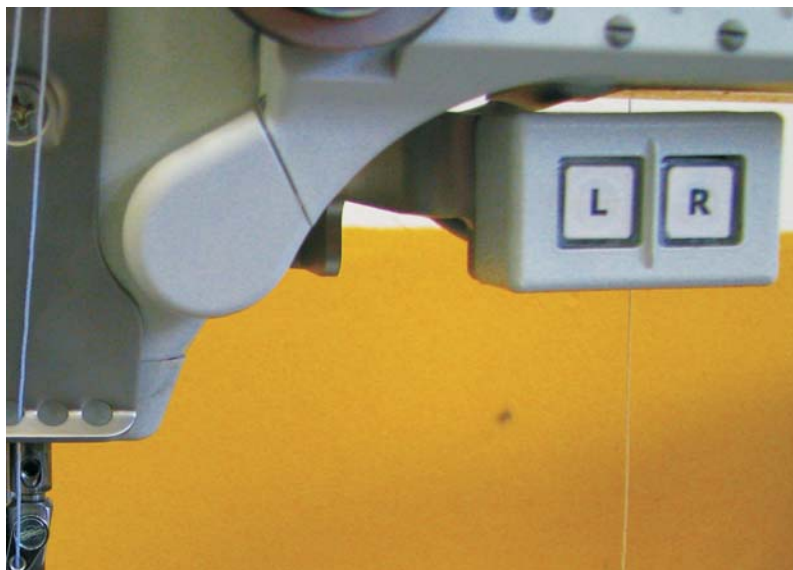

The needle bars are switched on and off with the “L” and “R” keys.

- Press the “L” key.  
The key is illuminated.  
The left needle bar is switched off.
- Sewing.
- Press the “L” key once more.  
The key is no longer illuminated.  
The left needle bar is switched on again.
  
- Press the “R” key.  
The key is illuminated.  
The right needle bar is switched off.
- Sewing.
- Press the “R” key once more.  
The key is no longer illuminated.  
The right needle bar is switched on again.

### **Note:**

It is not possible to switch off both needle bars at the same time. In order to switch on the second needle bar again both keys, “L” as well as “R” may be pressed.

## 7. Overview of positioning drives

### 7.1 DAC basic/classic/eco

#### 7.1.1 DAC basic/classic

DAC basic/classic control boxes are operated by means of the control panel OP1000, which is a part of the motor equipment. The difference between the basic and classic types of control boxes consists in the number of connectable peripheries. The software is updated by means of a separate DAC Dongle interface.

The control box can operate the minimotors M1-50 (500 W), M1-75 (750 W), or a direct drive installed on the sewing machine main shaft. For the variant with the minimotor it is possible to choose the installation on the sewing machine base plate and a toothed belt transmission, or the minimotor installation under the table top and a V-belt transmission. If the gear ratio is different from 1:1, an additional proximity switch should be used.

A detailed description of the control box is included in the "DAC basic/classic Operating manual" supplied by the motor manufacturer together with the sewing machine (see also [www.duerkopp-adler.com](http://www.duerkopp-adler.com)).

#### 7.1.2 DAC eco

The DAC eco control box contains all necessary control elements for the function switching and the parameter setting. The control panel cannot be connected. The software is updated by means of a DAC Dongle interface, which is common for the control pedal interface connection.

The minimotor M1-75 (750 W) is joined with the sewing machine with a toothed belt; it is possible to use a gear to achieve a higher torque. Then an additional proximity switch should be used.

A detailed description of the control box is included in the "Operating manual DAC basic/classic" supplied by the drive manufacturer together with the sewing machine (see also [www.duerkopp-adler.com](http://www.duerkopp-adler.com)).

## 7.2 Efka DA321G/DC1550

The DA321G control box includes all necessary control elements for the function switching and the parameter setting. The operation is possible even without the control panel; then the programmed sewing cannot be used. The software is updated by means of a separate USB interface.

Control panels V810 and V820, which are available as optional equipment, can be connected to the control box. The sewing can be programmed by means of the control panel V820.

The minimotor DC1550 is joined with the sewing machine with a V-belt; it is possible to use a gear to achieve a higher torque (see Assembly instructions, Setting of positioning motor Efka). Then an additional proximity switch should be used.

A detailed description of the control system is included in the Operating manual by the manufacturer "Efka DA321G-DC1550" drive supplied together with the sewing machine (see also [www.efka.net](http://www.efka.net)).

## 8. Sewing with machine equipped with positioning motor

### 8.1 Machine automatic functions

The machine has the below functions which are automatically performed during the seam sewing depending on:

- Pre-selection
- Pedal position (according to the machine operator's selection)
- Working phase of seam sewing

Automatic function	Pre-selection
Needle positioning	<ul style="list-style-type: none"> <li>• Needle down at machine stopping in seam</li> <li>• Needle up at machine stopping in seam</li> </ul> <p>Note: after the seam * finishing the machine stops always with the needle up.</p>
Bartacks	<ul style="list-style-type: none"> <li>• Standard</li> <li>• Decorative**</li> </ul>
Initial bartack	<ul style="list-style-type: none"> <li>• Single</li> <li>• Double</li> <li>• Standard bartack stitch number forwards</li> <li>• Decorative bartack stitch number forwards</li> <li>• Standard bartack stitch number backwards</li> <li>• Decorative bartack stitch number backwards</li> </ul>
End bartack	<ul style="list-style-type: none"> <li>• Single</li> <li>• Double</li> <li>• Standard bartack stitch number backwards</li> <li>• Decorative bartack stitch number backwards</li> <li>• Standard bartack stitch number forwards</li> <li>• Decorative bartack stitch number forwards</li> </ul>
Thread trimming	<ul style="list-style-type: none"> <li>• ON</li> <li>• OFF</li> </ul>
Automatic foot lifting	<ul style="list-style-type: none"> <li>• Foot lowered at stopping in seam</li> <li>• Foot lifted at stopping in seam</li> </ul>

\* The seam is finished after the pedal shifting to the position -2 (if the thread trimming is pre-selected, then after the trimming).

\*\* The decorative bartack is characterized by the fact that the needle sews stitch in stitch in the previous seam at the bartacking. At the sewing direction change the machine stops for a moment.

Pre-selections of automatic functions are described in the attached manual supplied by the drive manufacturer.

Every drive manufacturer supplies, together with the drive, a parameter sheet, by means of which other automatic functions can be set.

The parameter classification system is different with every drive manufacturer. To set the drive functions correctly, always study the manual supplied by the particular drive manufacturer. All instruction manuals and parameter sheets are available at the manufacturers' websites ([www.efka.net](http://www.efka.net), [www.duerkopp-adler.com](http://www.duerkopp-adler.com), [www.hohsing.com](http://www.hohsing.com) etc.).

## 8.2 Example of machine operation at sewing

### Pre-selection:

- Needle down at machine stopping in seam
- Standard bartacks
- Double initial bartack
- Double end bartack
- Thread trimming on
- Foot lowered at stopping in seam
- Foot lifted at seam finishing

Operation	Sewing procedure
	Machine stopped. Needle in upper position. Foot lifted.
Insert the material.	
Pedal treading to position +1.	Foot lowering.
Pedal release to position 0.	Foot lifting.
Material position correction.	
Pedal treading to position +1.	Foot lowering.
Pedal treading to position +3.	Sewing of standard double bartack (at speed pre-selected by producer and subsequent sewing at speed corresponding with third speed level +3.
Pedal release to position 0.	Machine stopping with needle down.
Pedal treading to position -1.	Foot lifting.
Turning of sewing material on needle	
Pedal treading to position +5.	Foot lowering and subsequent machine running to fifth speed grade of sewing.
Pedal treading to position -2.	Speed reduction. Sewing of standard double bartack. Thread trimming under throat plate and machine stopping with needle up. Foot lifting.
Pedal release.	(Foot remains lifted).
Remove the material.	



## 9. Maintenance

### 9.1 Cleaning and checking



#### Caution! Risk of injury!

Turn off the main switch.  
Maintenance may only be carried out with the machine switched off!



#### Caution!

The lacquered surfaces don't clear with organic solvent.  
For the cleaning are suitable detergents based on alcoholic.

Maintenance work must be carried out no less frequently than at the intervals given in the tables (see "operating hours" column).

Maintenance intervals may need to be shorter when processing heavy-shedding materials.

A clean machine is a trouble-free machine.

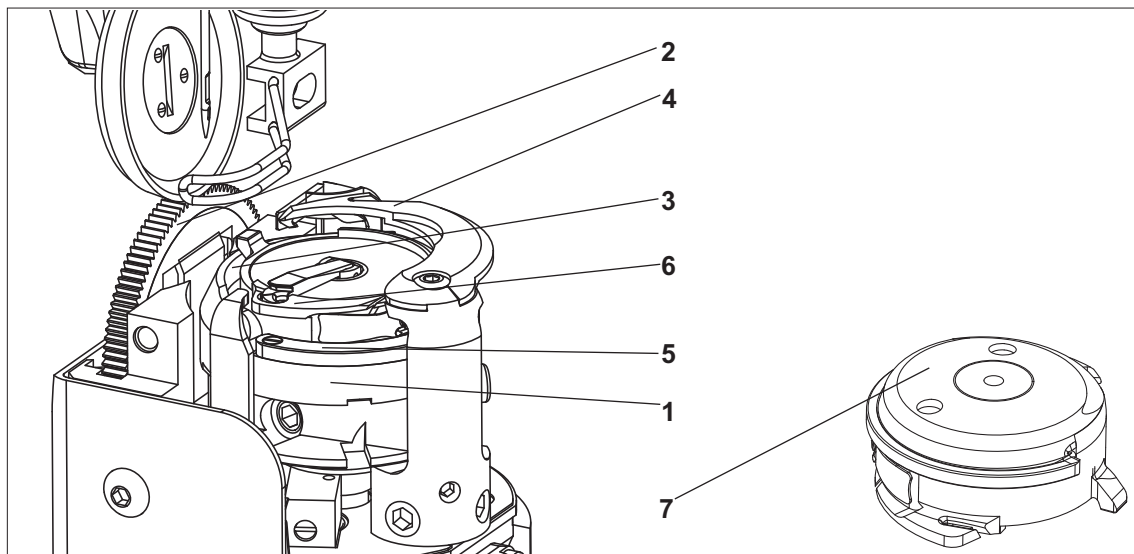

EN

Maintenance work to be carried out	Explanation	Operating hours
<b>Machine head</b> - Remove lint, pieces of thread (e.g. with an air blow gun)	Places in special need of cleaning: - Area under the throat plate, feeding roller (2), top roller and its surrounding. - Area around the hook (1) - Bobbin housing (6) - Thread trimmer - Area around the needle	8
	<b>CAUTION !</b> Be sure to hold the blow air gun so that no sewing dust is blown into the oil sump.	
- Remove lint, pieces of thread (e.g. with an air blow gun)	Remove the throat plate. Remove the thread pulling knife (4). Remove the hook plunger ring (5). Remove the bobbin housing (6) from the hook. Clean the inner area of the hook. Clean the bobbin housing - particularly look for glue remainder on the surface (7).	20
- Check the hook	Check the clearance on the track between bobbin housing (6) and the hook (1).	500

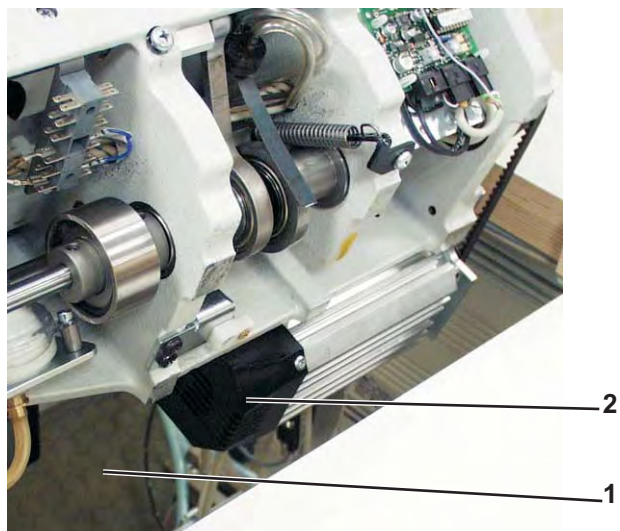

Maintenance work to be carried out	Explanation	Operating hours
- Clean the oil sump	Clean the oil sump (1) of dirt and contaminated oil. (you may use a special vacuum cleaner.)	20
- Clean fan grille	Remove lint and pieces of thread from air-intake openings (2) (e.g. with an air blow gun).	20

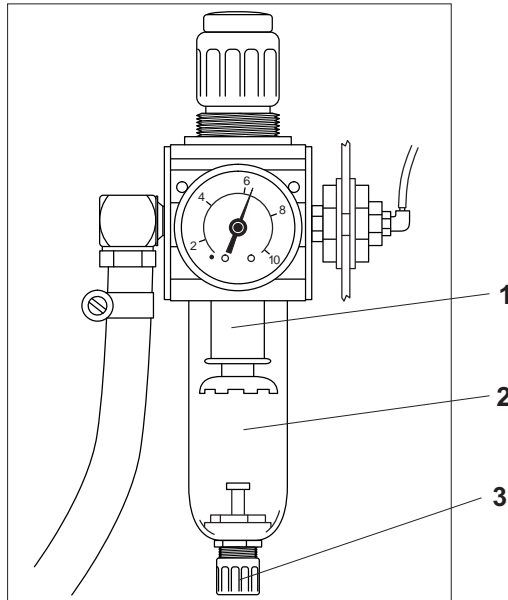

Maintenance work to be carried out	Explanation	Operating hours
<b>Pneumatic system</b>		
- Check water level in pressure regulator.	The water level must not rise to the level of the filter cartridge (1). - After unscrewing the drain screw (3), the water under pressure will flow out of the water separator (2).	40
- Clean filter cartridge.	Dirt and condensation are separated out by the filter cartridge (1). - Disconnect the machine from the compressed-air supply. - Unscrew the drain screw (3). There must be no pressure in the machine's pneumatic system. - Unscrew water separator (2). - Unscrew filter cartridge (1). Wash the filter shell and cartridge with cleaning fluid (not solvent) and blast clean. - Re-assemble the maintenance unit.	500
- Check the system for leaks.		500

## 9.2 Lubrication

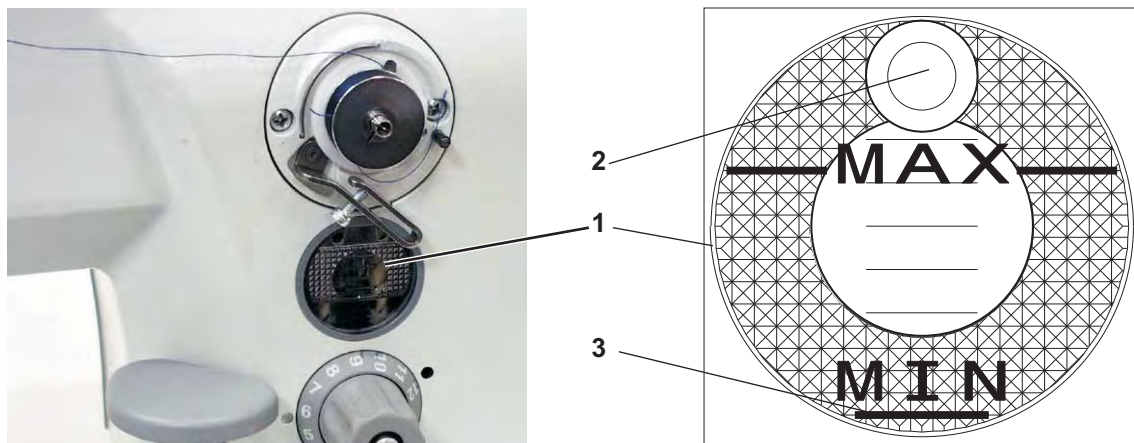

### Caution! Risk of injury!

Oil can cause skin eruptions.  
Avoid protracted contact with the skin.  
In the event of contact, thoroughly wash the affected area.



### Caution!

The handling and disposal of mineral oils is subject to legal regulation.  
Deliver used oil to an authorised collection point.  
Protect your environment.  
Take care not to spill oil.

To lubricate the special sewing machine use only **DA-10** lubricating oil or an equivalent oil of the following specification:

- Viscosity at 40° C: 10 mm<sub>2</sub>/s
- Flashpoint: 150° C

**DA-10** is available from **DÜRKOPP ADLER AG** retail outlets under the following part numbers:

- 250-ml container: 9047 000011
- 1-litre container: 9047 000012
- 2-litre container: 9047 000013
- 5-litre container: 9047 000014

All points of the sewing machine head lubricated with oil are supplied from the central tank (1).

- If the oil volume drops to the level (3), supply the oil through the hook path (2) to the "MAX" level.
- Check the oil level every day!



### Caution! Risk of failure!

The oil may be supplied only into the central tank or in the hook path.  
The other points must not be lubricated separately, so that the oil does not penetrate to the spots, which must not be lubricated.

**Part 2: Assembly Instructions Class 888 - Original Instructions**

<b>1</b>	<b>Scope of delivery</b> . . . . .	<b>3</b>
<b>2</b>	<b>Transport packing of assembled machine</b> . . . . .	<b>4</b>
<b>3</b>	<b>Assembling the stand</b>	
3.1	Assembling the stand components . . . . .	4
3.2	Assembling the table top . . . . .	5
3.2.1	Assembling the table top in the machine with the direct drive . . . . .	5
3.2.2	Assembling the table top with the minimotor . . . . .	6
3.2.3	Mounting the pressure regulator for the sewing foot to the table top . . . . .	7
3.3	Setting the working height . . . . .	9
<b>4</b>	<b>Assembling the machine head</b>	
4.1	Fitting the machine head . . . . .	10
4.2	Fitting the side guards . . . . .	11
4.3	Adjustment of pedal position . . . . .	12
4.4	Fitting the knee lever and oil pump pipe . . . . .	13
4.5	Fitting the connecting cable, control panel and sewing diode lamp on the machine head . . . . .	14
<b>5</b>	<b>Electrical connection</b>	
5.1	Electrical connection to low voltage network . . . . .	15
5.2	Sewing light transformer connection to network voltage . . . . .	16
5.3.	Earthing . . . . .	18
5.4	Connection of machine head electric equipment to drive. . . . .	19
<b>6</b>	<b>Basic adjustment the positioning drives</b>	
6.1	DAC basic/classic drive. . . . .	21
6.2	DAC eco drive . . . . .	21
6.3	Efka drive . . . . .	22
<b>7</b>	<b>Pneumatic connection</b> . . . . .	<b>23</b>
<b>8</b>	<b>Lubrication</b> . . . . .	<b>24</b>
<b>9</b>	<b>Sewing test</b> . . . . .	<b>24</b>

Notes:

# 1 Scope of delivery

The purchaser can order a complete machine, or some components only. Prior to setting up, please check that all the required parts are present. This description refers to a special sewing machine, of which all individual components can completely be delivered by **Dürkopp Adler AG**. A complete supply of the disassembled machine depends on the selected drive and consists of the following components:

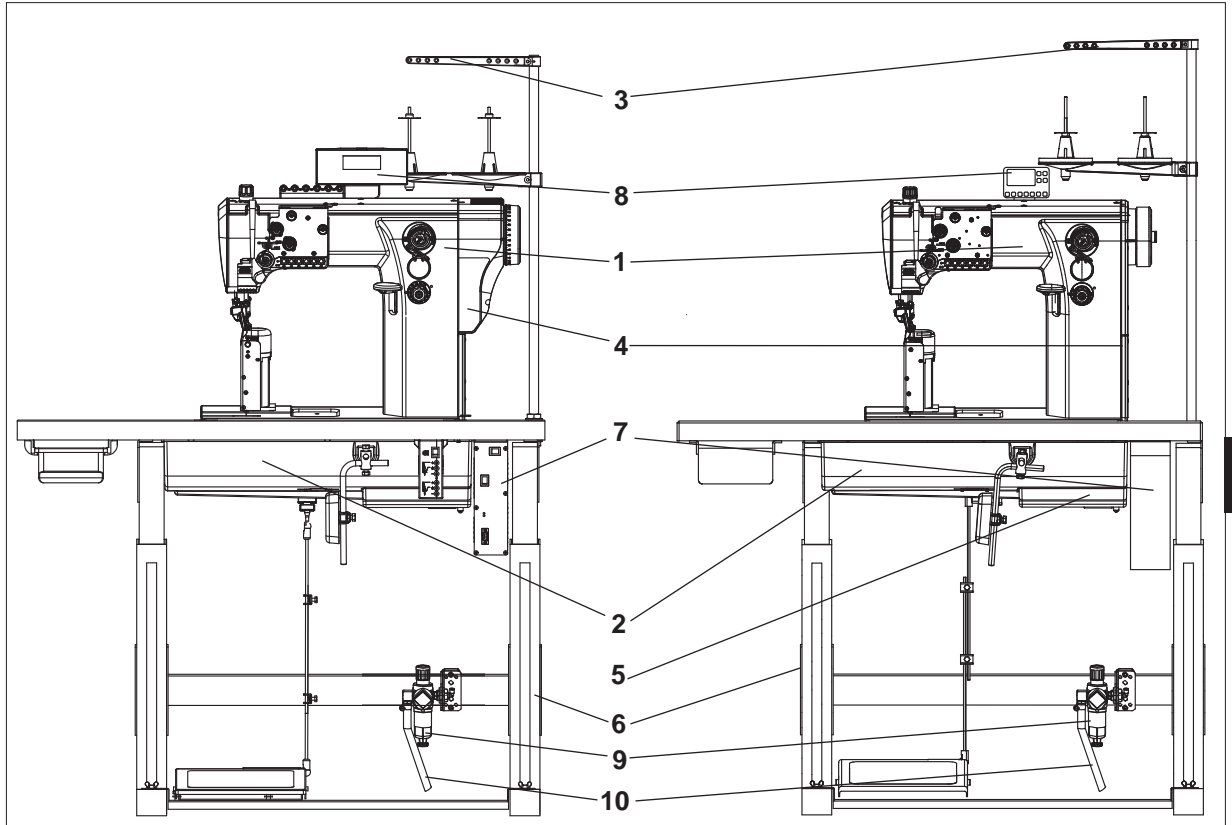

EN

Machine with the direct drive	Machine with the minimotor
Obligatory components:	
Machine head with drive (1)	Machine head (1)
Accessories (includes oil tank (2), yarn stand (3), tools and other items)	Accessories (includes oil tank (2), yarn stand (3), tools and other items)
Set of parts for motor (includes guard (4), control unit (7), control panel (8) and other parts)	Set of parts with motor (includes minimotor (5), control unit (7), belt guard (4) and other parts)
Optional components:	
Stand (6)	Stand (6)
	Control panel (8)
Maintenance unit (9)*	Maintenance unit (9)*
Pneumatic connection package (10)*	Pneumatic connection package (10)*

\*only for subclasses with pneumatics

## 2 Transport packing of assembled machine

If the machine is supplied in assembled condition, the following transport packing must be removed:

- Safety straps and wooden battens on the machine head and stand.

## 3 Assembling the stand

### 3.1 Assembling the stand components

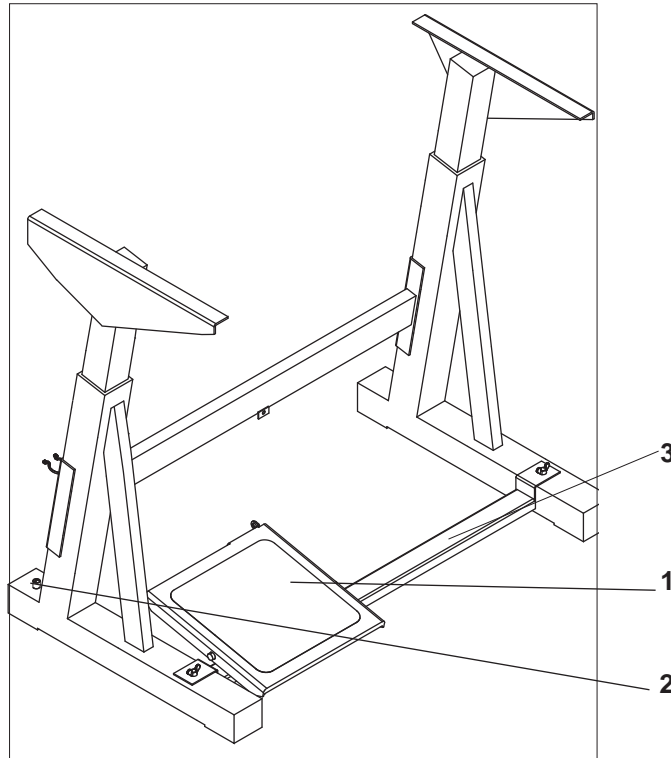

- Mount the frame according to the picture. Mount the pedal (1) provisionally to the cross strut frame (3). Its position will be adjusted after the whole machine is complete.
- Adjust the screw (2) so that the stand is stable.



## 3.2 Assembling the table top

### 3.2.1 Assembling the table top in the machine with the direct drive

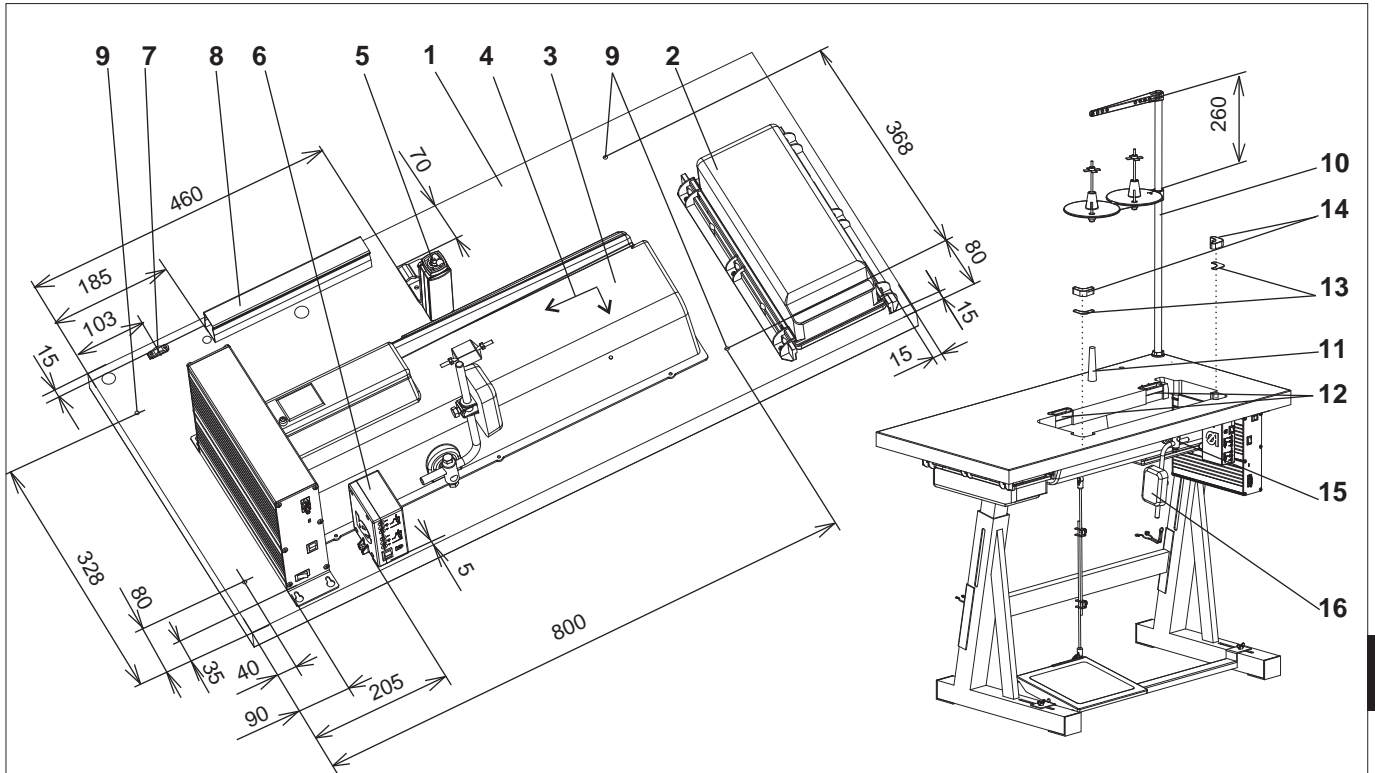

- Turn the table top (1) upside down.
- Screw the drawer (2).
- Put the oil sump (3) on the recess in the table top and slide it in the arrow direction (4) till the relevant protrusions of the oil sump are seated on the recess contour. Screw the oil sump.
- Screw the pedal position sensor (5).
- Screw the sewing lamp transformer (6) – if there is any.
- Screw the cable clip (7).
- Screw the electric cable channel (8).
- Mount electric cables according to par. 5 of this instruction.
- Pre-bore the holes (9) with a borer  $\varnothing$  3 mm. Attach the table plate (1) to the stand with woodscrews. Then turn the stand to normal position.
- Insert the yarn stand (10) in the hole in the table plate and secure it with the nuts and washers. Fit and align the yarn reel and unwinding holders.
- Insert the machine head support pin (11).
- Place the hinge bottoms (12) for the machine head into the cutout of the table plate (1) and tighten the screws.
- Insert the wedges (13) in the recess corners.
- Insert the rubber cushions (14).
- Remove the blinds from the bushing (15).
- Remove the knee lever (16) and guide through the opening, as shown in the illustration.

### 3.2.2 Assembling the table top with the minimotor

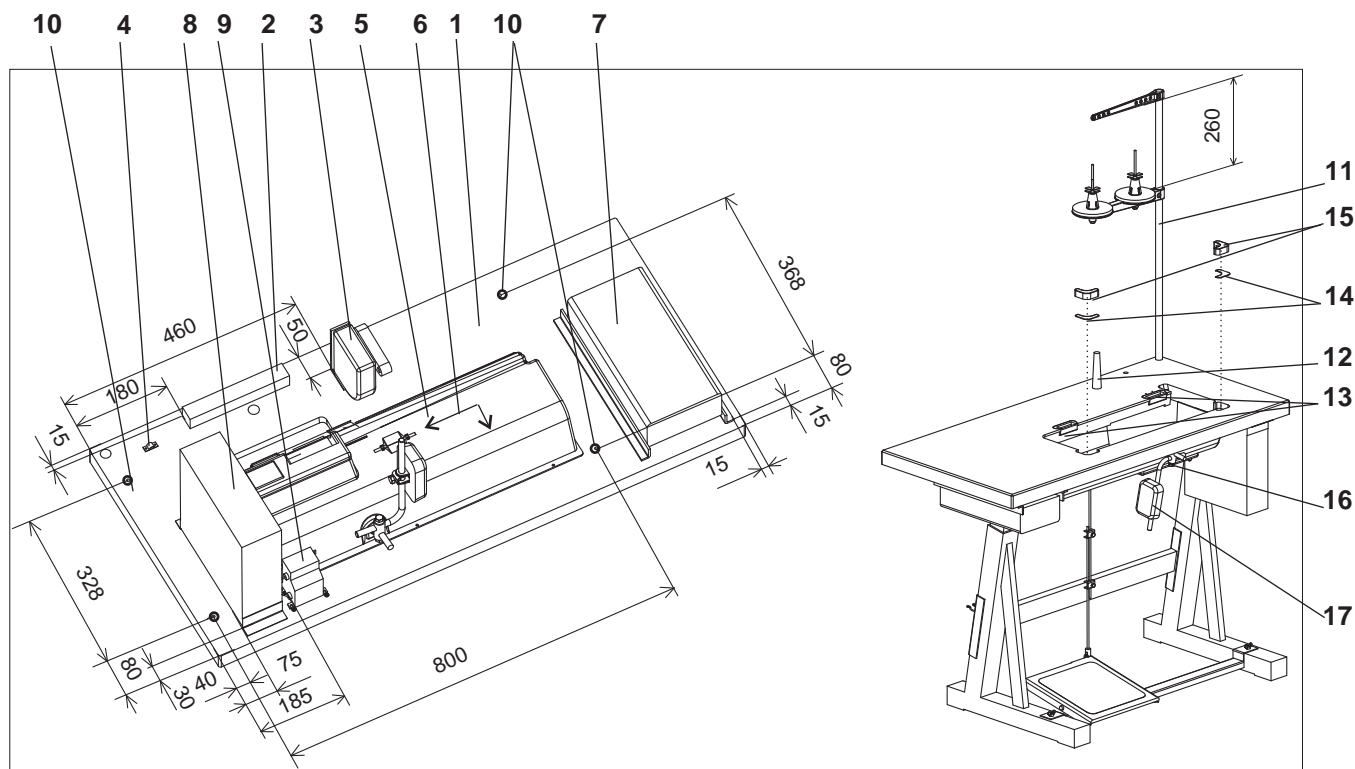

- Turn the table top (1) upside down.
- Screw the electric cable channel (2).
- Screw the pedal position sensor (3).
- Screw the electric cable clip (4).
- Put the oil sump on (5) and slide it in the arrow direction (6) till the relevant protrusions of the oil sump are seated on the recess contour. Screw the oil sump.
- Screw the drawer (7).
- Pre-bore the holes for wood screws and screw the drive control box (8).
- Screw the sewing lamp transformer (9) – if there is any.
- Mount electric cables according to the instructions in chapter 5.
- Pre-bore the holes (9) with a borer  $\varnothing$  3 mm. Attach the table plate (1) to the stand with woodscrews. Then turn the stand to normal position.
- Insert the yarn stand (11) in the hole in the table plate and secure it with the nuts and washers. Fit and align the yarn reel and unwinding holders.
- Insert the machine head support pin (12).
- Place the hinge bottoms (13) for the machine head into the cutout of the table plate (1) and tighten the screws.
- Insert the wedges (14) in the recess corners.
- Insert the rubber cushions (15).
- Remove the blind from the bushing (16).
- Remove the knee lever (17) and guide through the opening, as shown in the illustration.

### 3.2.3 Mounting the pressure regulator for the sewing foot to the table top

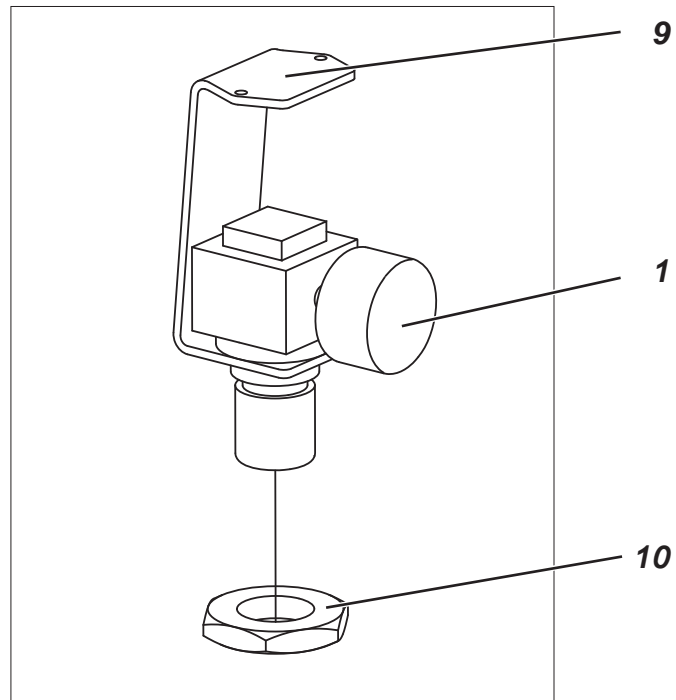

- Put the pressure regulator (1) in the holder (9) and secure it using the nut (10).
- Mount the components of the pneumatic circuit to the table top as shown in the illustration below.

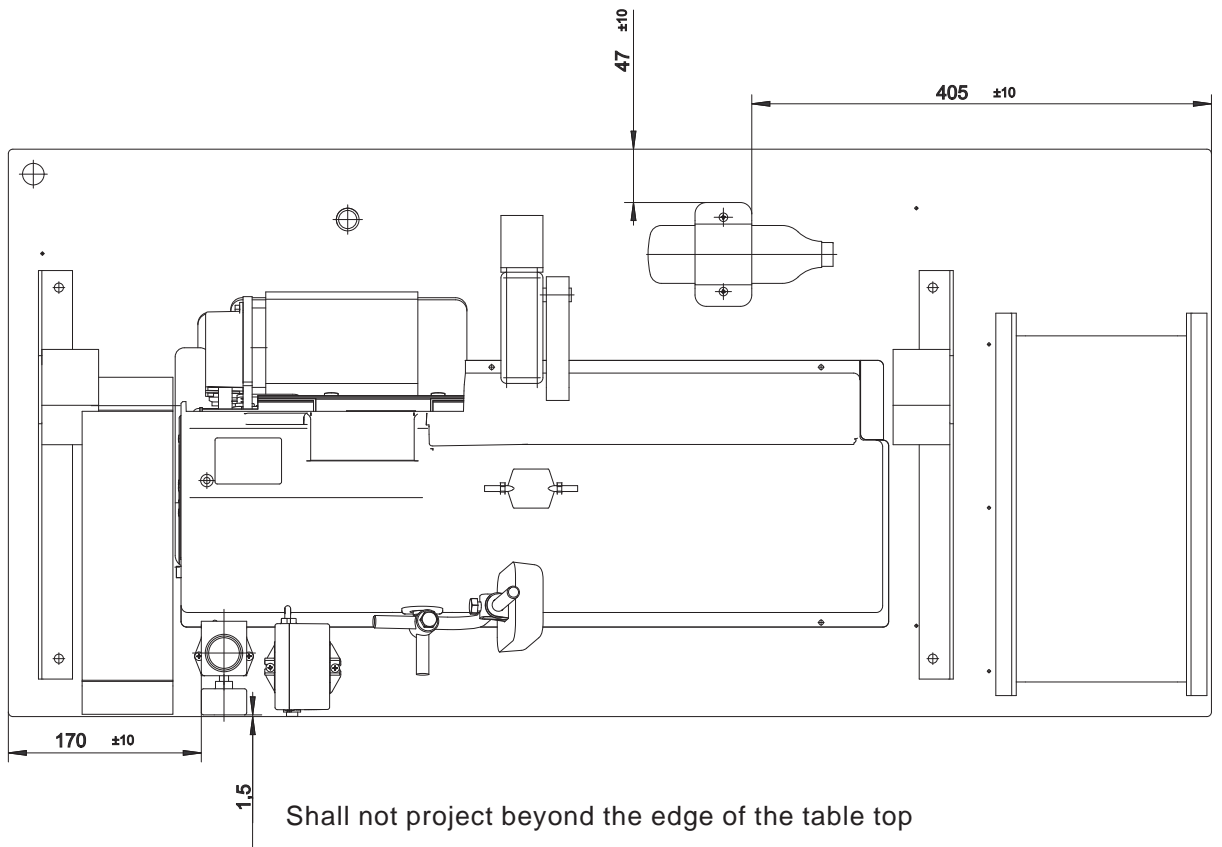

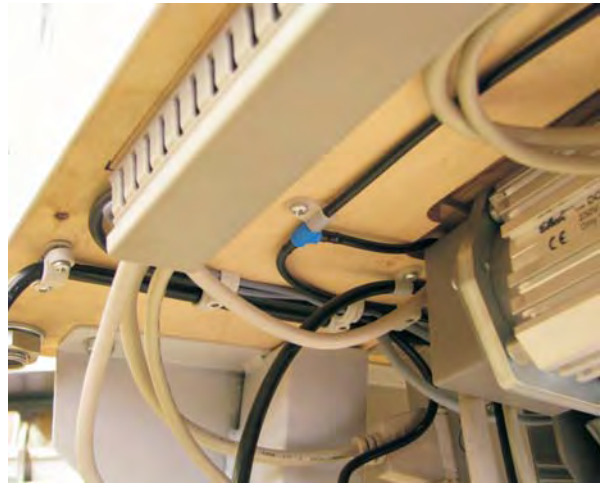
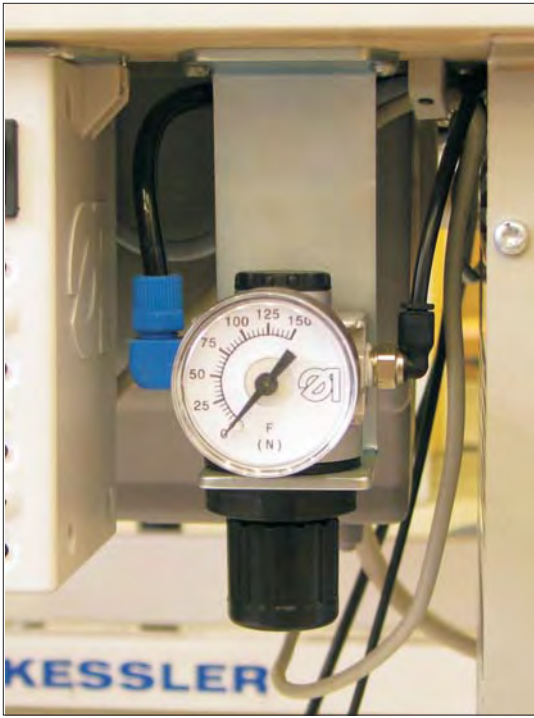

Connect the components of the pneumatic circuit according to the drawing below.

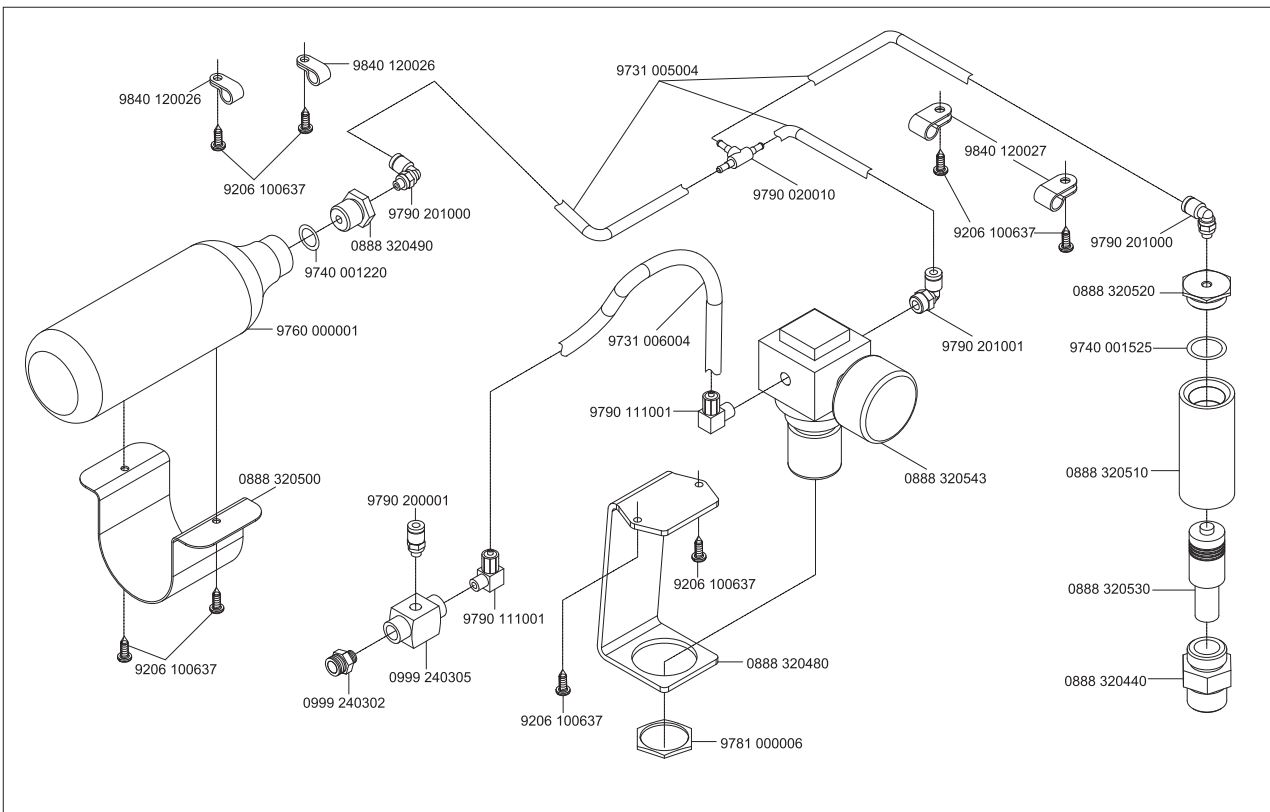

### 3.3 Setting the working height

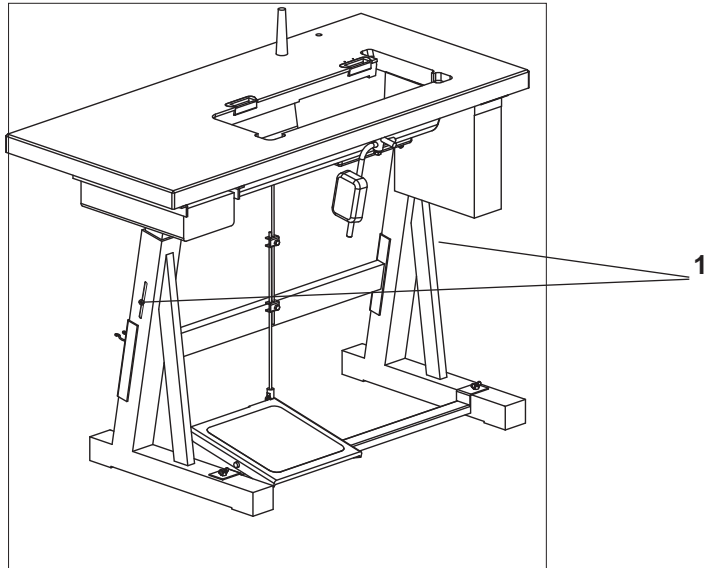

- The stand height is adjustable between 750 and 900 mm.
- Loosen the screws (1).
- Set the required table top height and make sure that it is identical on both sides. To do that, use the scale on the stand feet. Set the stand height so that it corresponds with the operator's body proportions.
- Tighten both screws (1).

EN



#### **Caution! Risk of injury!**

Failure to adjust the stand height to the operator's body proportions can cause damage to the operator's locomotion system.

## 4 Assembling the machine head

### 4.1 Fitting the machine head

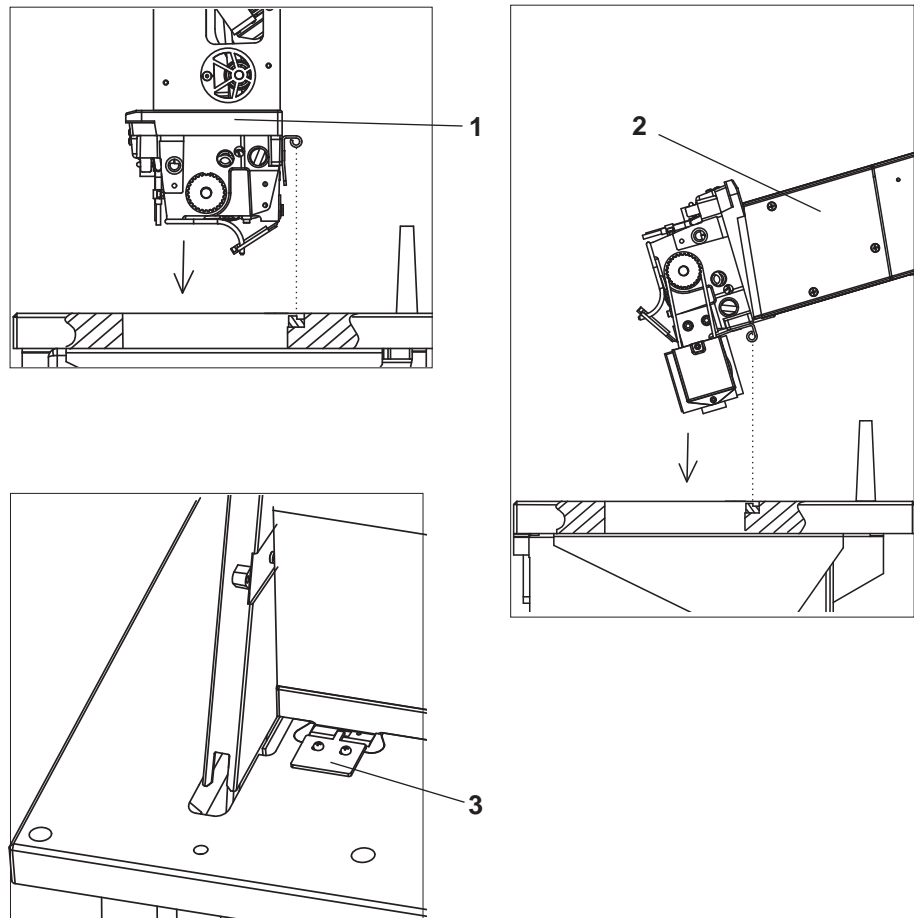

- If the sewing machine is equipped with a direct drive, insert the machine head (1) vertically in the recess in the table top.
- If the sewing machine is equipped with a minimotor, tilt the machine head (2) and insert it in the table top recess.
- After the head insertion, screw the locking plate (3) immediately to secure the machine head against falling out at its tilting. The locking plate is part of the machine head accessories.

## 4.2 Fitting the side guards

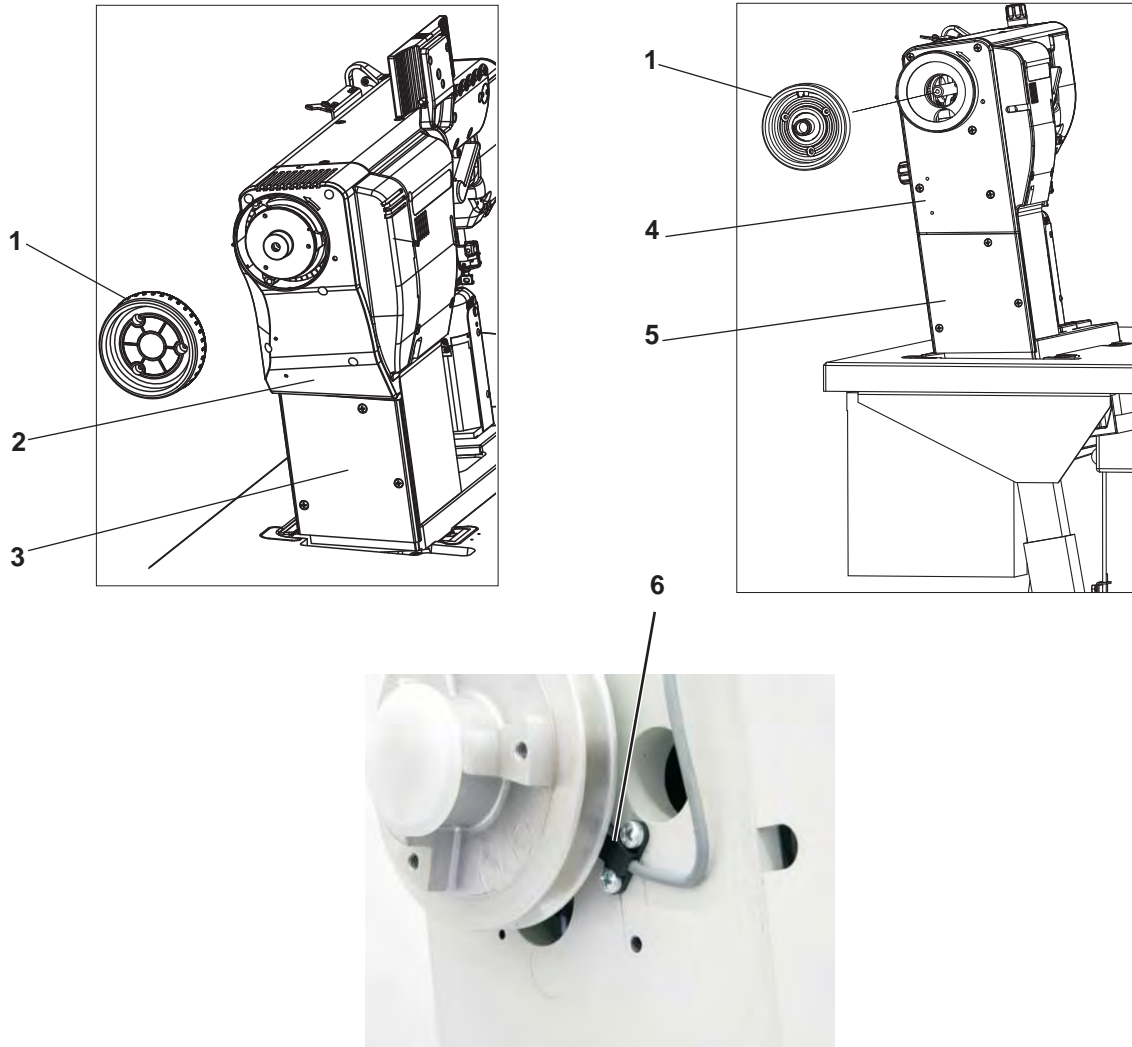

EN

- Disassembly the hand wheel (1).
- In the machines with the direct drive mount the guards (2) and (3) on the machine head (the guard is included in of the motor part set).
- In the machines with the motor on the sewing head and with 1,55:1 toothed belt driving gear, mount the proximity switch (6). It is included in the "kit for motor".
- In the all machines with the motor on the sewing head mount the guards (4) and (5) on the machine head (the guard is included in of the motor part set).
- Mount the hand wheel (1). Doing this, observe the correct angle position: if the needle is in the upper dead point, there should be the 0° value on the hand wheel scale.

### 4.3 Adjustment of pedal position

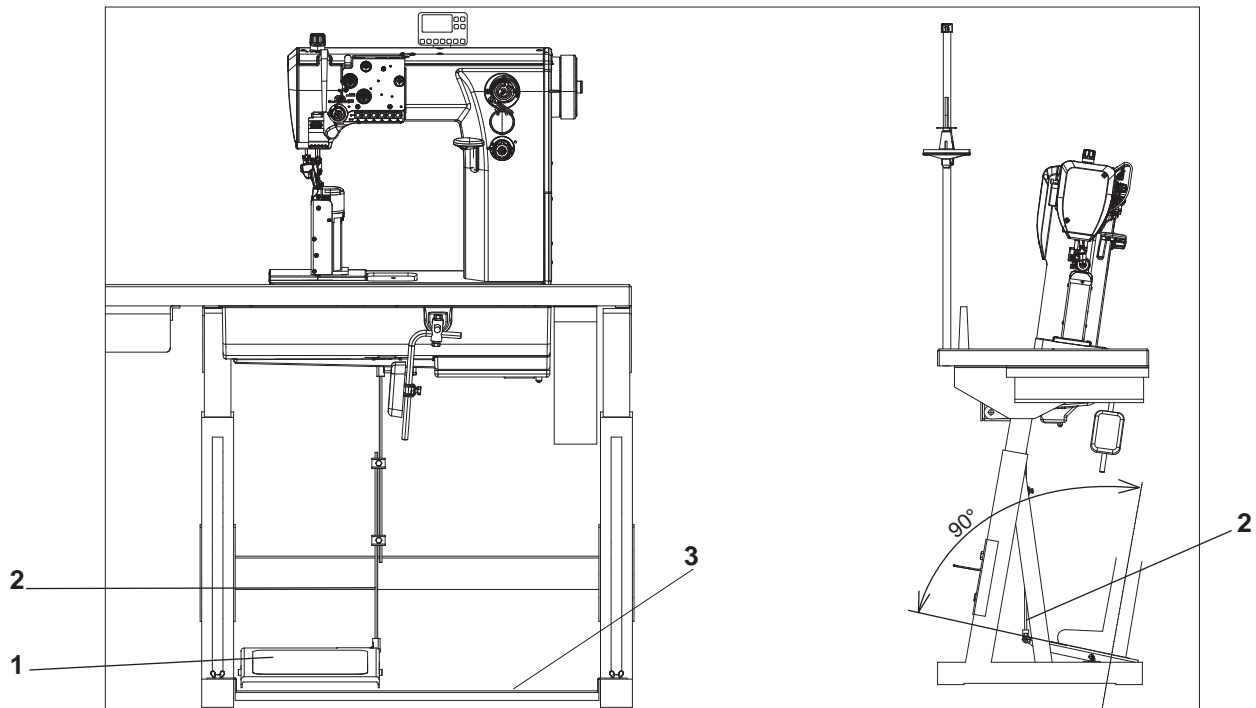

- For ergonomic reasons align the pedal (1) as follows:  
The center of the pedal must be approximately under the needle.  
There are slots in the cross strut frame (3) to help align pedal.
- Adjust the draw rod (2) so that the foot axis is perpendicular to the pedal surface.



#### **Caution! Risk of injury!**

Failure to keep the determined pedal position can cause damage to the operator's locomotion system. .



#### 4.4 Fitting the knee lever and oil pump pipe

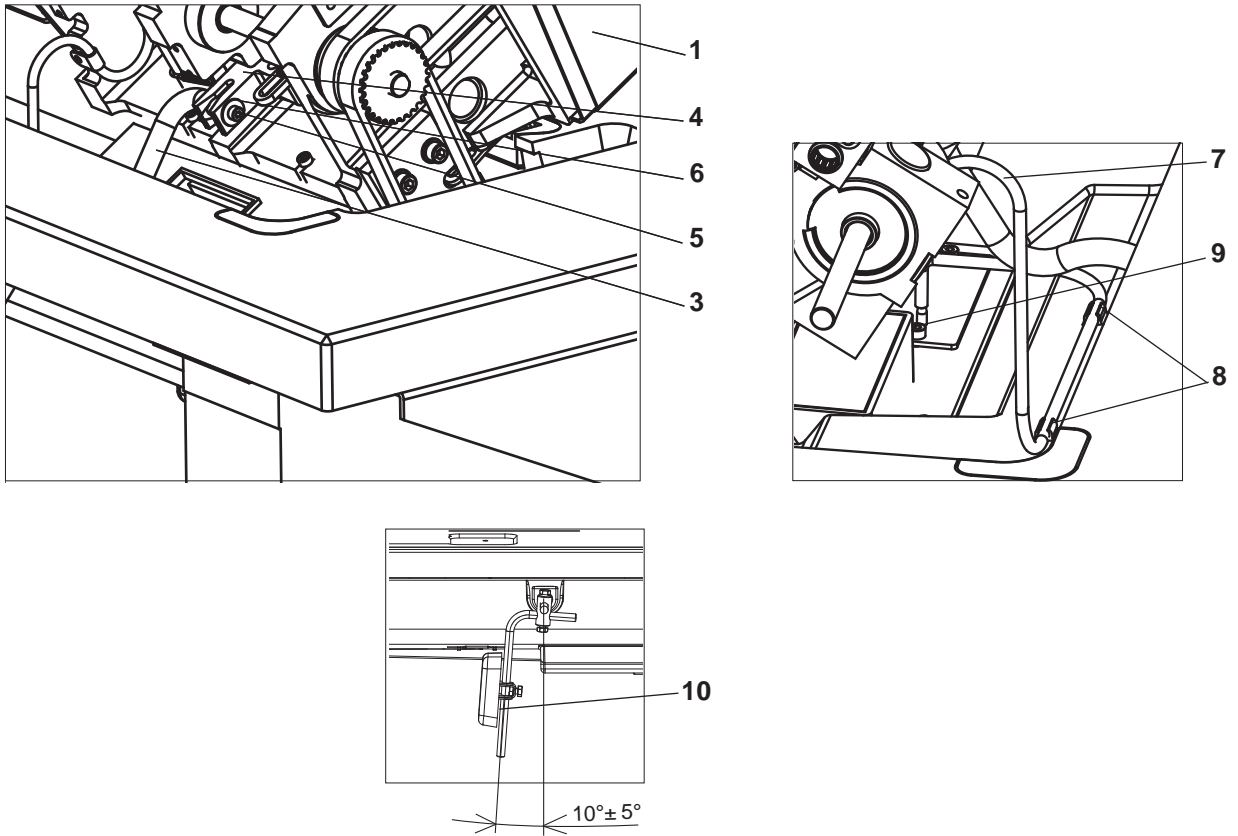

- Lift the sewing foot with the hand lever.
- Tilt the machine head (1).
- Slide the shaft (3) in the lever (4).
- Screw the screw (5) with the washer (6) in the shaft (3).
- Attach the pipe (7) with the clips (8) and install the suction basket (9).
- Tilt the machine head and adjust the knee lever (10) according to the picture.
- Adjust the knee pad.

#### 4.7 Fitting the connecting cable, control panel and sewing diode lamp on the machine head

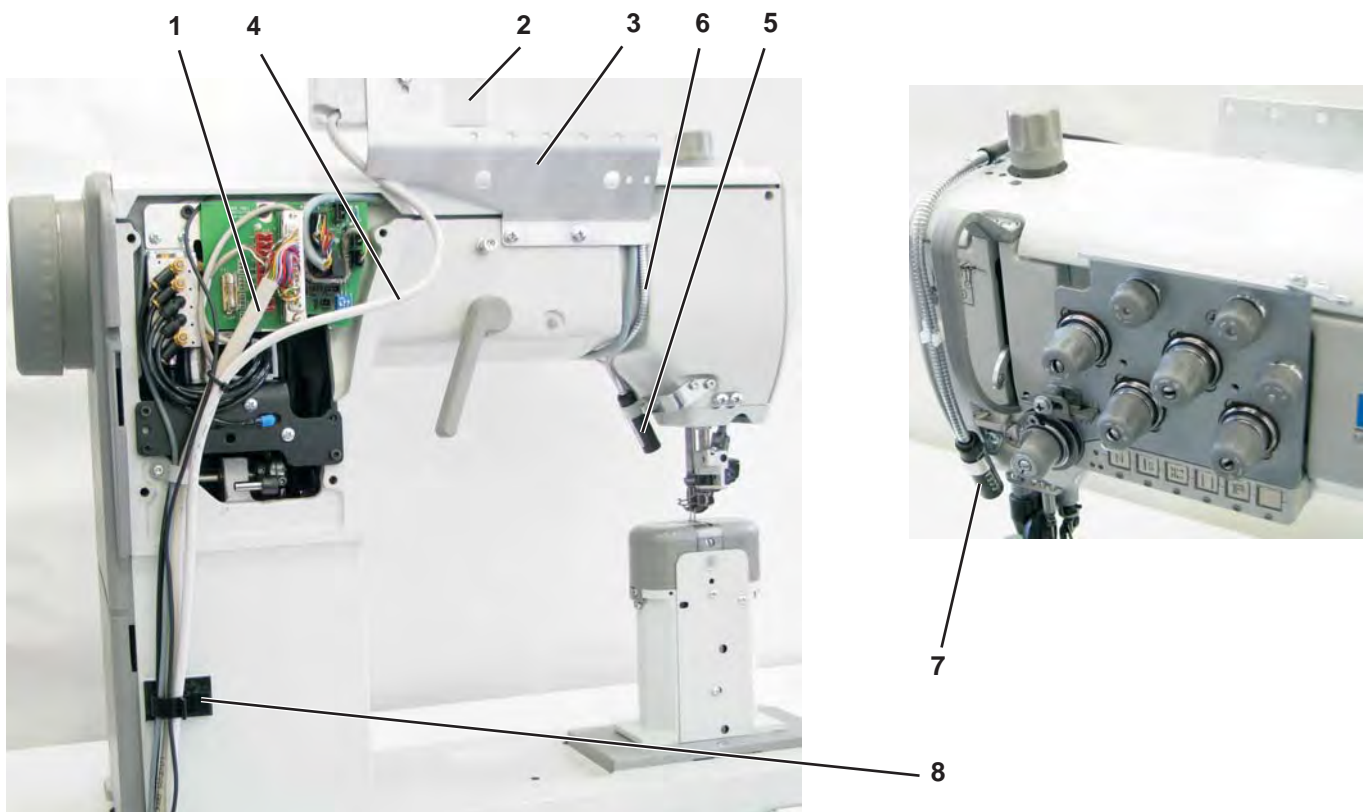

- A 37 pole connecting cable (1) is supplied with every sewing machine equipped with a positioning motor.
- The control panel (2) is an optional item of the Efka drives. If ordered, it is always supplied with a holder (3). The control panel is always an integral part of the DAC basic/classic drives.
- A diode sewing lamp with a power LED-module (5) is an optional item. Two types of holders are supplied with the module enabling to mount the sewing lamp in two positions. The position (5) is basic. The position (7) is used if a sewn material guide or the material edge trimmer is installed on the machine.
- Dismantle the upper and rear cover of the sewing machine head.
- Install the connecting cable with the 37 pole connector (1) according to the picture. Fix the cable ends against pulling out with screws on the switchboard side and on the control box side.
- Mount the control panel (2) with the holder (3) on and install its cable (4) according to the picture.
- Mount the sewing lamp (5) on and install its cable (6) according to the picture. The power supply cable should be connected to the transformer, which is supplied either separately, or, in the variant with a direct drive, it can be a part of the switchboard.
- Push the cables through the table top and attach them with a self-sticking clip (8).

## 5 Electrical connection



### Caution!

All work on the electrical equipment of this special sewing machine may only be carried out by qualified electricians or other appropriately trained persons.

It is unconditionally necessary to study the instructions for the motor (drive) supplied by the producer!

### 5.1 Electric connection of machine to low voltage network

The control DAC classic or DAC basic is connected to a grounded alternating low voltage network with the rated voltage in scope 180V - 260V, 50/60Hz. For the Efka DA321G drive the supply voltage is 230 V  $\pm$  10%, 50/60 Hz.



### Caution!

The mains voltage must agree with the rated voltage specified on the model-identification plate.

EN

The connection may be realized only by means of a multipole socket with a protective contact. A fixed connection is inadmissible.

All instructions for the drive connection can be found in the Operating manual for the DAC basic/classic drives or for the Efka drive.



### Caution! Risk of electric current injury!

The drives may be operated only with a safety conductor connected to the functional protective system in accordance with the regulations and rules to avoid personal injuries by electric current or fire.

The drive operation will become dangerous if the safety conductor inside or outside the drive is disrupted. The protection must not be disrupted with e. g. an extension cord without the protective conductor.

## 5.2 Sewing lamp transformer connection to network voltage



### Caution! Risk of electric current injury!

The sewing lamp transformer is not switched off by the main switch (EN 60 204-31)! At the sewing lamp installation and repair inside the transformer box, e.g. at a fuse replacement, the network plug must be disconnected from the network unconditionally.

The control boxes DAC basic/classic and Efka DA321G are equipped with a terminal box for the connection of a sewing lamp external transformer to the voltage 230V/AC or 24V/DC 1,5W (DAC).

A special adaptor 9870 001033 is supplied with the control box DAC eco for the connection of the sewing lamp transformer.

A. The machine is equipped with the DAC basic/classic drive

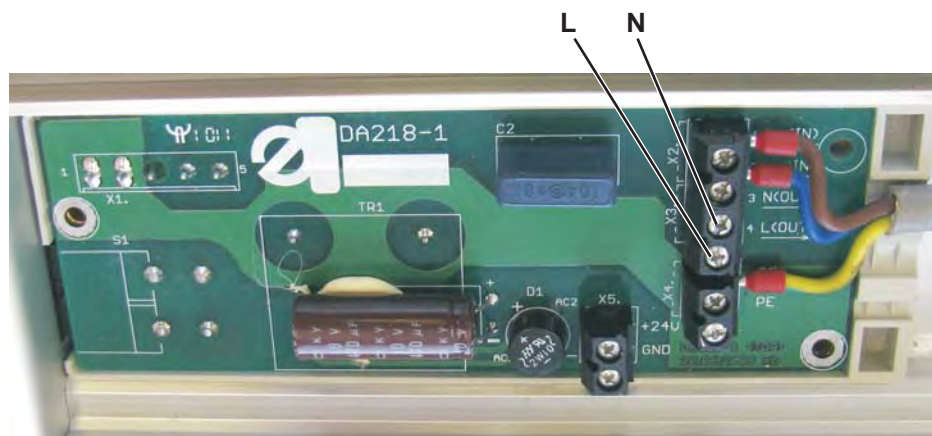

- Pull the plug out of the electric network socket!
- Dismantle the terminal box plastic cover on the control box.
- Connect the transformer cable of the sewing lamp according to the instructions included in the operating manual of the DAC drive (power supply terminals (L, N) for the transformer are parallel to the power supply).
- Before the back installation of the cover break the plastic blind with a suitable tool to run the cable out of the terminal box.

B. The machine is equipped with the Efka DA321G drive

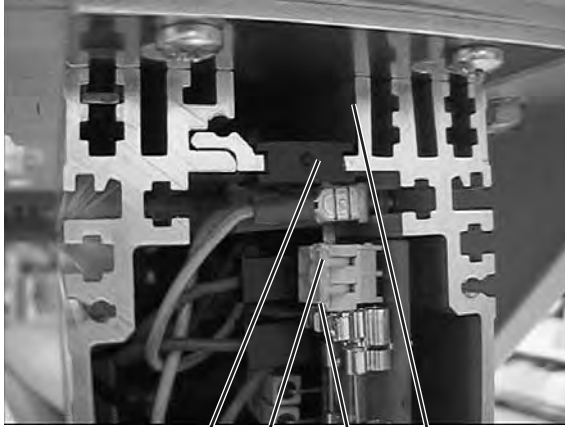

2 6 5 1



6 5 4 3

- Pull the network plug out of the socket.
- Screw out 4 screws on the front panel of the control box.
- Dismantle the front panel.
- Pull the transformer cable through the channel (1) in the control box.
- Remove the black rubber bushing (2).
- Pierce the bushing with a screwdriver.
- Pull the sewing lamp transformer cable through the arisen hole.
- Insert the rubber bushing back again.
- Press the clip openers (3) and (4) with a small screwdriver slightly until the clips (5) and (6) open.
- Connect the blue conductor to the terminal (6) and the brown conductor to the terminal (5).
- Screw the front panel back again.

EN

## 5.3 Earthing

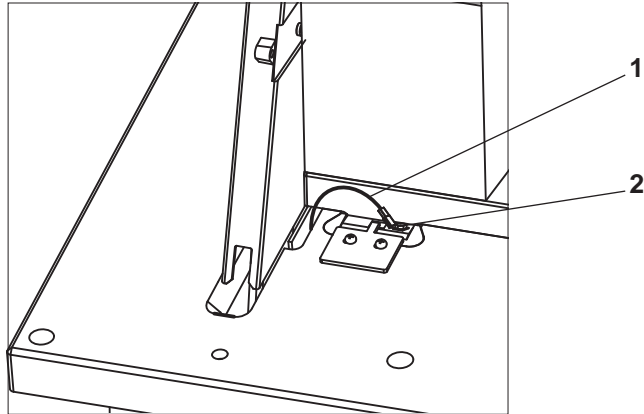

- Mount the earthing cable (1) if it is included in the accessory package of the machine head.
- Connect the earthing cable (1) to the plug (2) (already screwed on the head hinge) and pull its opposite end under the table top.
- Screw the opposite end of the grounding conductor to the relevant grounding point of the drive.
- Attach the cable with a clip on the bottom side of the table top.



### **Caution!**

Make sure that the earthing cable (1) does not touch the driving V-belt (if there is any).

### **Note:**

You do not need to care for the earthing with machines having the sewing motor fit onto the machine head, since it is already established through the fitted motor.

## 5.4 Connection of machine head electric equipment to drive

A. The machine is equipped with the DAC basic/classic drive

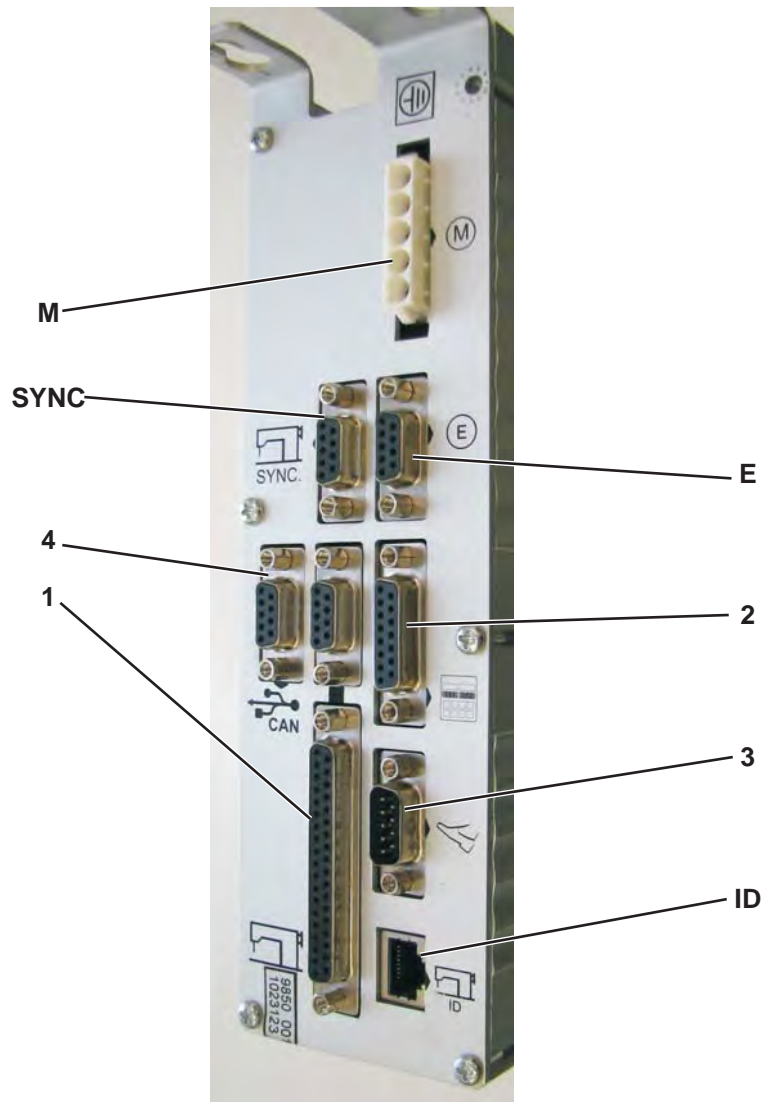

- Connect the sewing head connection cable into the connector (1) signed with the machine symbol.
- Connect the control panel into the connector (2) signed with the panel symbol.
- Connect the motor encoder connector into the connector (E).
- Connect the motor connector into the connector (M).
- Connect the pedal position sensor into the connector (3) signed with the pedal symbol.
- Connect "machine identification" into the connector ID.
- Connect the proximity switch to the connector (SYNC) if the sewing machine has a gear ratio different from 1:1.
- The connector (4) is used for the connection of other peripherals, e. g. a knee lever or an electric hand wheel.

B. The machine is equipped with the Efka DA321G drive

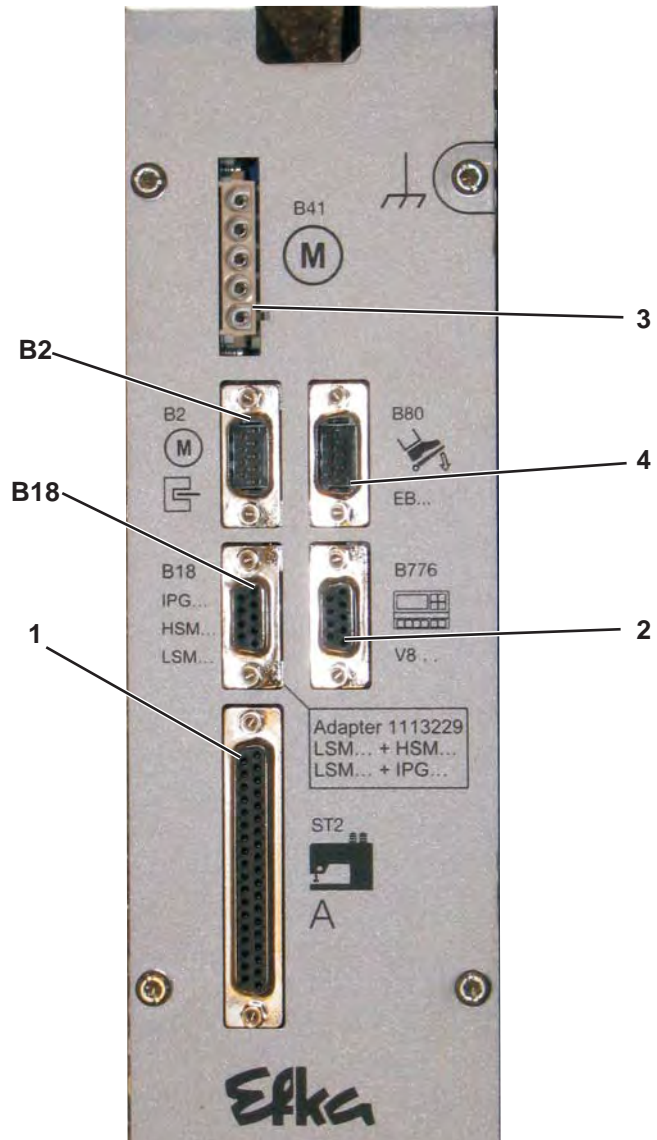

- Connect the machine head connecting cables to the connector (1).
- Connect the control panel to the connector (2).
- Connect the position sensor connector in the motor to the connector (B2).
- Connect the motor connector to the connector (3).
- Connect the pedal position sensor to the connector (4).
- Connect the proximity switch to the connector (B18).



## 6 Basic adjustment of the positioning drives

The function of the positioning motor is determined by its program, setting of the motor parameters and stop positions of the sewing machines. If the sewing machine is supplied in a disassembled condition, the motor should be set by the purchaser. If the sewing machine is supplied in an assembled condition, the motor has already been set by the sewing machine manufacturer.



### Attention!

The parameter value must be changed with consideration and responsibility. A wrong setting of the control can cause the damage of the sewing machine!

### 6.1 DAC basic/classic drive

The sub-class of this drive type has already been pre-set in the purchased control unit on condition that the sub-class is known to the manufacturer; i. e. a complete sewing machine and a drive have been purchased. This can be changed either by a new software installation by means of a DAC Dongle device and by a subsequent selection of the sub-class, which is done when a separate control unit DAC has been bought. Another possibility is the installation of the parameter set by connecting a so-called sewing machine identification (Masch.ID) with the existing parameter set of the particular sub-class to the DAC unit. This possibility can be made use of if the client has already owned the same sewing machine with the DAC drive, and when the client wants to copy the parameter set from that.

After the parameter set installation it is necessary to set the reference position for the correct positioning (usually, the needle tip at the level of the throat plate) at the parameter **t 08 10**, and then to adjust, if needed, the maximum sewing speed at the parameter **t 08 00**.

Detailed information and a detailed description of the parameter setting is included in the publication "Operating instructions DAC basic/classic" enclosed by the drive manufacturer, "Parameter sheet DAC basic/classic", which is specific for the particular sub-class, or at the website [www.duerkopp-adler.com](http://www.duerkopp-adler.com).

### 6.2 DAC eco drive

The same rules are applicable to the DAC eco drive for the sub-class selection, and the software installation is the same as for the DAC basic/classic drives. Only the hardware manufacture of the units is different, and that is why the interface for the DAC Dongle device is common with the control pedal interface, and the parameter setting is realized by means of the pushbuttons on the control box front panel.

Detailed information with a detailed description of the parameter setting is included in the publication "Operating instructions DAC eco" enclosed by the drive manufacturer, or at the website [www.duerkopp-adler.com](http://www.duerkopp-adler.com).

## 6.3 Efka drive

The drive parameter setting is realized in two steps. As the first step, parameters are set for a group of sewing machine classes by means of the function "auto select". This is done automatically according to the connected cable or switchboard where the so-called auto select resistor is contained. As the second step, the particular sub-class is selected at the parameter <290>, by means of which the parameters specific for this sub-class are automatically uploaded.

Example:

For the auto select 680 W the following sewing machine sub-classes are available:

Parameter <290>:	Sub-class:
1	4180 (1:1)
2	4280 (1:1,4)
3	888, 887, 884 (1:1), solenoids
4	888, 887 (1:1,5), pneumatic
5	838, 887, 888 (1:1,5), pneumatic

Then the reference position is set at the parameter <170>, which is necessary for the correct positioning of the sewing machine (usually, the needle tip at the level of the throat plate), or it is adjusted, as needed, to the maximum sewing speed at the parameter <111>.

The software can be updated by means of a separate USB interface on the control box front panel.

Detailed information with a detailed description of the parameter setting is included in the publication "Operating instruction Efka DA321G" enclosed by the drive manufacturer, or at the website [www.efka.net](http://www.efka.net).

## 7 Pneumatic connection

CLASSIC machines with pneumatics.



### Attention!

The special sewing machine's operating pressure is 6 bar.

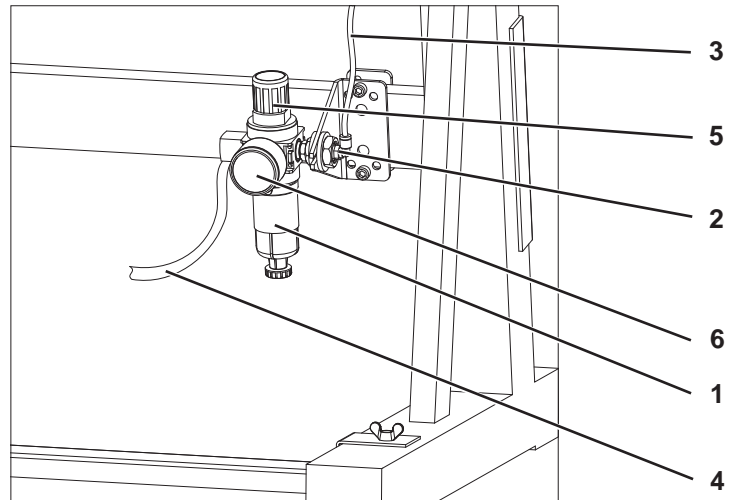

- Mount the maintenance unit 1 to the stand brace as shown in the illustration.
- Screw in the elbow fitting 2 (in the accessories) and connect the hose 3 from the machine head to the elbow fitting 2.
- Fix the connection hose 4 as shown in the illustration and connect the other end with the coupling to the compressed air supply system.
- Raise and turn the handle 5 to set the pressure to 6 bar on the manometer 6. Press the handle 5 again.
- If the machine is equipped with the pneumatic driven sewing foot with constant pressure, connect it to the maintenance unit as shown in the picture below.

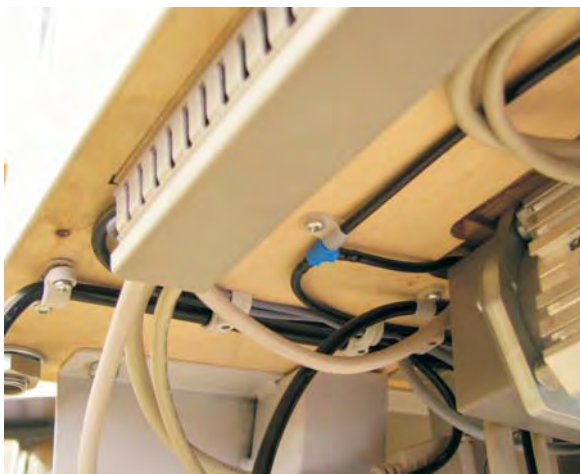

EN

## 8 Lubrication

Before start, the machine must be lubricated properly with oil according to chapter 9.2 in the operating instructions.

## 9 Sewing test

This test can be carried out only after the machine is set completely.

- Thread in the bobbin-winder thread. (see operating instructions).
- Turn on the main switch.
- Lock the sewing foot in the lifted position (see operating instructions).
- Fill the bobbin at low speed.
- Turn off the main switch .
- Thread in needle thread and bobbin thread (see operating instructions).
- Select the material to be sewn.
- Carry out the sewing test first at low speed and then gradually increase the speed.
- Check whether the seams are of the desired quality.
- If the quality requirements are not met change the thread tensions (see Operating instructions).





DÜRKOPP ADLER GmbH  
Potsdamer Str. 190  
33719 Bielefeld  
Germany  
Phone: +49 (0) 521 925 00  
e-mail: [service@duerkopp-adler.com](mailto:service@duerkopp-adler.com)  
[www.duerkopp-adler.com](http://www.duerkopp-adler.com)