



884

Service Instructions

All rights reserved.

Property of Dürkopp Adler GmbH and copyrighted. Reproduction or publication of the content in any manner, even in extracts, without prior written permission of Dürkopp Adler GmbH, is prohibited.

Copyright © Dürkopp Adler GmbH - 2021

Introduction

This service booklet contains the instructions for setting the sewing machine head mechanisms.

The directions for putting the machine into operation and for setting the positioning drive are contained in another publication.

The service booklet is common for all subclasses of the machine and contains also the instructions for setting optional accessories of the machine, if this is necessary owing to their complexity. Provided the machine supplied does not contain some elements, then the respective chapters may be ignored.

The succession of the setting operations is expressed here by sequencing the paragraphs of this booklet. When setting, check up, if the setting operations related to this setting have already been performed.

General safety instructions

The non-observance of the following safety instructions can cause bodily injuries or damages to the machine.

1. The machine must only be commissioned in full knowledge of the instruction book and operated by persons with appropriate training.
2. Before putting into service also read the safety rules and instructions of the motor supplier.
3. The machine must be used only for the purpose intended. Use of the machine without the safety devices is not permitted. Observe all the relevant safety regulations.
4. When gauge parts are exchanged (e.g. needle, presser foot, needle plate, feed dog and bobbin) when threading, when the workplace is left, and during service work, the machine must be disconnected from the mains by switching off the master switch or disconnecting the mains plug.
5. Daily servicing work must be carried out only by appropriately trained persons.
6. Repairs, conversion and special maintenance work must only be carried out by technicians or persons with appropriate training.
7. For service or repair work on pneumatic systems, disconnect the machine from the compressed air supply system (max. 7-10 bar). Before disconnecting, reduce the pressure of the maintenance unit. Exceptions to this are only adjustments and functions checks made by appropriately trained technicians.
8. Work on the electrical equipment must be carried out only by electricians or appropriately trained persons.
9. Work on parts and systems under electric current is not permitted, except as specified in regulations DIN VDE 0105.
10. Conversion or changes to the machine must be authorized by us and made only in adherence to all safety regulations.
11. For repairs, only replacement parts approved by us must be used.
12. Commissioning of the sewing head is prohibited until such time as the entire sewing unit is found to comply with EC directives.
13. The line cord should be equipped with a country-specific mains plug. This work must be carried out by appropriately trained technicians (see paragraph 8).



It is absolutely necessary to respect the safety instructions marked by these signs.

Danger of bodily injuries !

Please note also the general safety instructions.



Service Instructions for the Class 884

(Edition 11.2021)

1	General	
1.1	Setting gauges	5
1.2	Adjusting the handwheel	6
1.2.1	Sewing machine with minimotor	6
1.2.2	Sewing machine with direct drive	7
2	Bottom feed	
2.1	Basic setting for stitch adjustment and stitch length limit	8
2.2	Stitch uniformity for forwards and reverse stitching	9
2.3	Adjusting of feed shaft position and clutch lever position	10
2.4	Position of the eccentric tappet for the feed movement	11
2.5	Switching over the feed clutch	12
2.6	Position of the eccentric tappet for the switch over of the feed clutch	13
2.7	Checking the switch over of the feed clutch	14
2.8	Wheel feed	15
3	Top feed	
3.1	Position of the needle holder with single needle sewing machines	17
3.2	Needle feed	18
3.3	Roller foot	20
3.4	Roller foot lifting	21
3.5	Variator of the roller foot drive	22
4	Adjusting the needle bar and the hook	
4.1	Hook height	23
4.2	Needle bar height, play of needle to hook tip, loop stroke	24
4.3	Hook tip guard	25
4.4	Bobbin housing release	26
4.2	Hook lubrication	27
5	Thread setting	
5.1	Thread regulator, check spring, bolt for the thread lever mechanism	28
5.2	Bobbin winder.	29
6	Thread cutter	
6.1	Thread-pulling knife height	30
6.2	Starting position for the thread pulling knife.	31
6.3	Angle position (timing) of control cam and clearance between cam and roller	33
6.4	Bobbin thread clamp.	34

7	Electronic control and sewing machine drive - positioning motor	35
7.1	Terminals to PCB connections - electromagnetic variant	36
7.2	Terminals to PCB connections - pneumatic variant	37

1 General

These service instructions describe the adjustments that can be made to the class **884** special sewing machine.



CAUTION!

The operations described in these service instructions may only be carried out by qualified staff or other appropriately trained persons!



Caution: Risk of injury!

Turn the main switch off for repair, conversion and maintenance work and separate the machine from the pneumatic supply line.

Any adjustment work and functional testing with the machine running should be conducted only under observance of all safety measures and with the greatest possible caution.

EN

These service instructions describe the adjustment of the sewing machine in a logical order. Please observe that various setting positions are dependent on each other. Thus it is essential that the settings be conducted while keeping to the order described.

For all adjustments of parts involved in the stitch formation, a new undamaged needle must be inserted.

This text does not specifically mention any machine covers or panels which must be removed or re-mounted in order to conduct inspections or adjustments.

Note

Some shafts on the special **884** machine are provided with flat eccentric surfaces. This significantly simplifies machine adjustments.

For all adjustments on flat surfaces, the first screw screwed in the direction of the eccentric surface.

1.1 Setting gauges

The retention pin required for adjusting the machine is included with all units. It is located with the machine accessories and can be attached so that it is easily accessible below the oil tray.

1.2 Adjusting the handwheel

Rule:

The handwheel (4) is labelled with degree numbers.

Certain adjustments are made with these marked handwheel positions.

- Turn the handwheel until the degree value specified in the instructions is aligned with the pointer (3).
- Proceed with the adjustment described.

When the needle bar is at top dead centre, the pointer (3) should be aligned with “0” degrees.

1.2.1 Sewing machines with minimotor

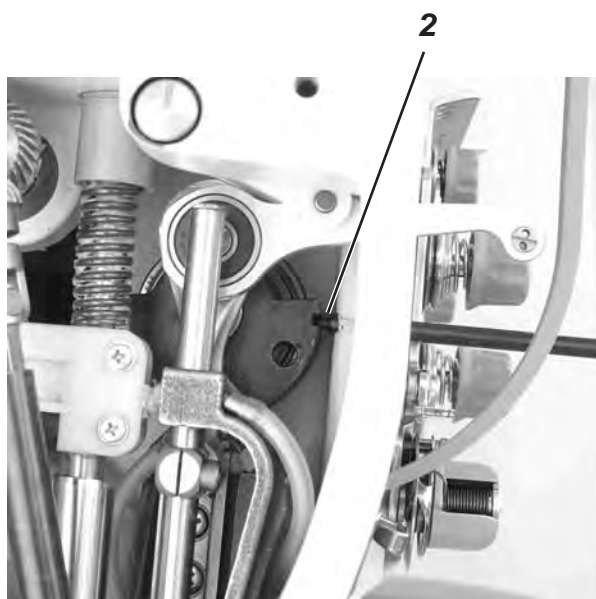
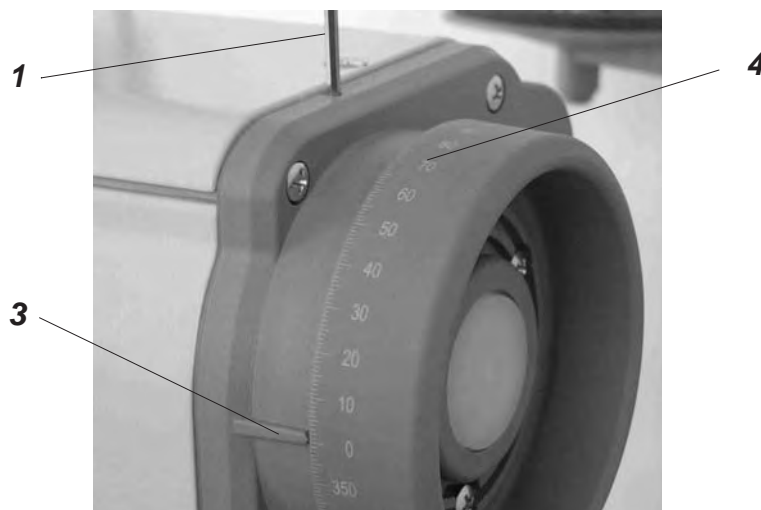

- Loosen the handwheel screws with a 3 mm Allen key (1).
- Position the needle bar in the upper dead centre position. Use the retention pin (3 mm diameter) to peg the position (2).
- Turn the handwheel so that the pointer (3) points to 0 degrees on the rotary scale.
- Tighten the first screw with the Allen key (1). Turn the handwheel to 50° and tighten the second screw with the Allen key (1).

1.2.2 Sewing machine with direct drive

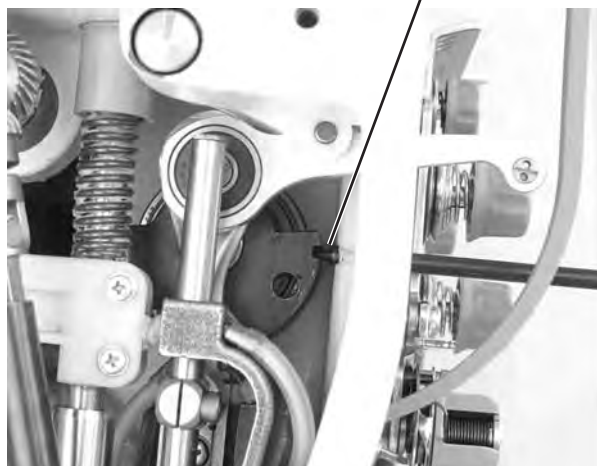
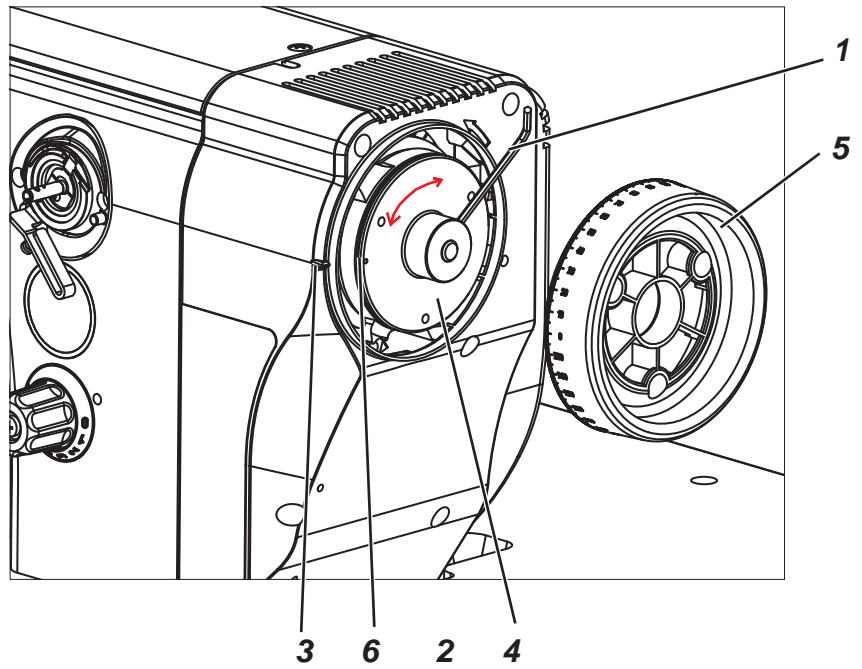

- Unscrew three fixing screws on the hand wheel (5) and remove it.
- Put the needle in the upper dead point and insert the setting pin (2), which is a part of the sewing machine accessories and which is fixed on the oil tray bottom side, into the crank head.
- Loosen two setting screws of the hand wheel flange (4) with the Allen key 3 mm (1).
- Turn the hand wheel flange with the hollow (6) against the sign (3).
- Tighten both setting screws with the key (1) and fix the hand wheel on again.

2 Bottom feed

2.1 Basic setting for stitch adjustment and stitch length limit

Rule:

1. When setting the stitch length at "0", the stitch regulator gear should have as little play (clearance) as possible when you press down on the bartacking lever.
2. The maximum stitch length limit depends on the material to be sewn and the sewing equipment being used (see operating instructions).

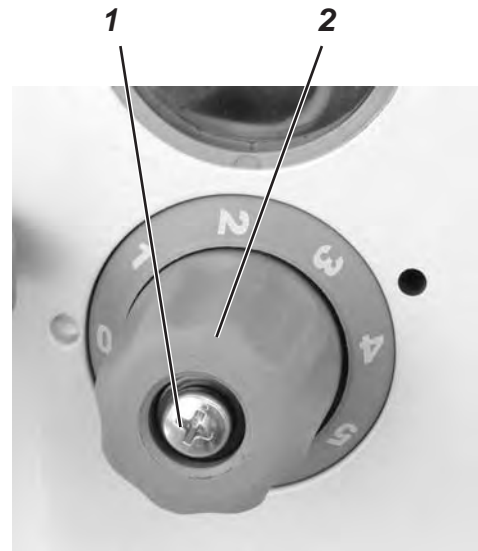
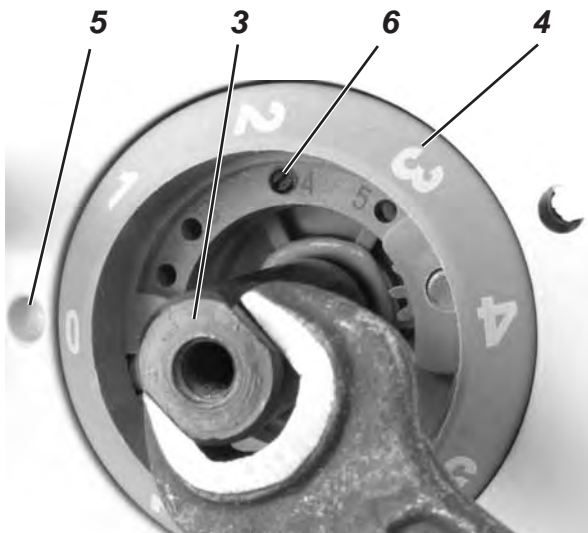

- Loosen screw (1) and take off the settings dial (2).
- Turn the screw (3) as far as needed to the right using a 10 mm open-ended wrench. Verify that the stitch regulator gear is without motion by pressing down on the bartacking lever. This fulfills rule 1.
- Set the scaling ring (4) with stitch length "0" to align with the circular mark (5).
- Limit the stitch length according to rule 2. For this, screw the retention pin (6) into the proper hole. The holes are marked with numbers which indicate the maximum stitch length.
- Put the settings dial (2) back on and tighten the screw (1).



Caution: Risk of injury!

Turn the main switch off.

Only carry out this basic stitch adjustment when the machine is turned off.

2.2 Stitch uniformity for forwards and reverse stitching

Rule:

1. When making a rough-scale adjustment to the stitch regulator gear, the machine should not feed when the stitch length is set to "0".
2. When making a fine-scale adjustment to the stitch regulator gear, the forwards and reverse stitch lengths should only deviate in value by a half stitch.

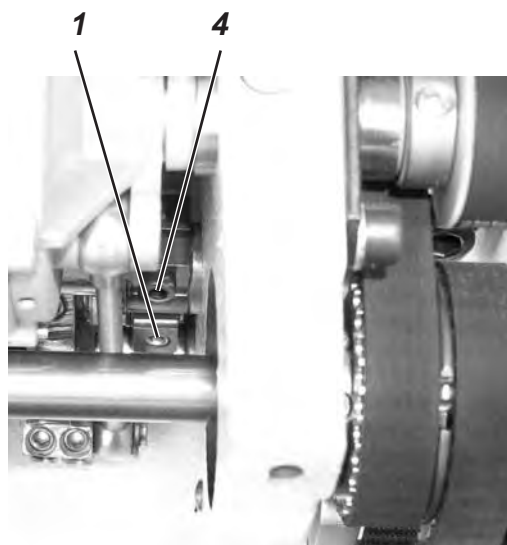
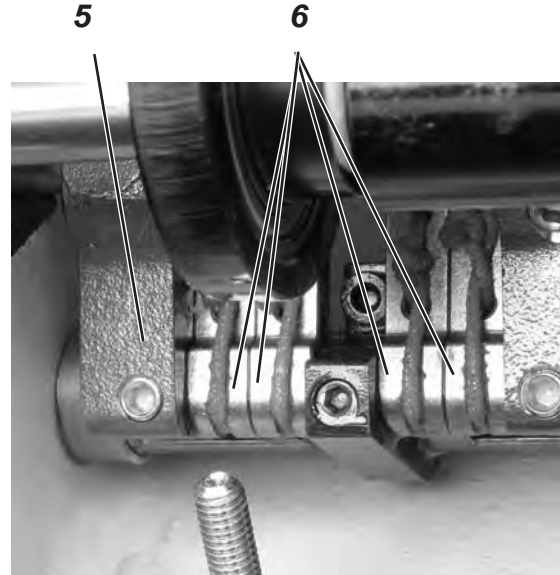
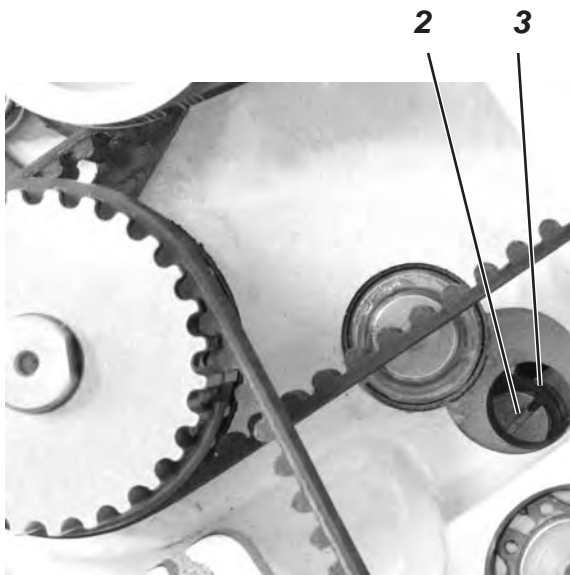

- Set the stitch length to "0".
- Loosen screw (1) and turn the grooved (3) eccentric tappet (2) according to the illustration. Fasten with screw (1).
- Loosen screw (4) on the clamping lever. Turn the settings frame (5) so that the shackles (6) are parallel. Tighten screw (4). This then fulfils rule 1.
- The next step is to match up the forwards and reverse stitch lengths. Sew ten stitches forwards. Press the bartacking lever and then sew ten stitches backwards. Rotate the eccentric tappet (2) so that rule 2 is fulfilled.
- Clockwise = increase forward stitch, decrease reverse stitch.
- Counter-clockwise = decrease forward stitch, increase reverse stitch.

2.3 Adjusting of feed shaft position and clutch lever position

Rule:

When setting the stitch length to "0" the groove on the feed shaft front side is in the vertical position. The feed clutch should be in the central position.

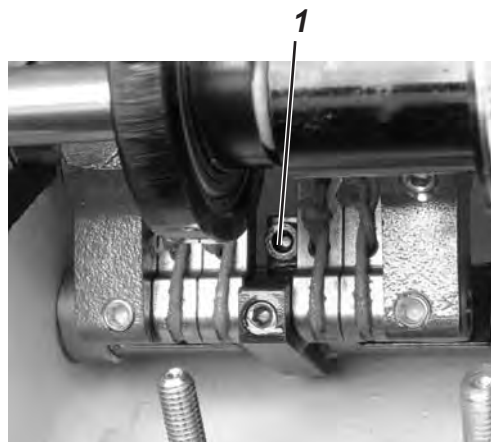
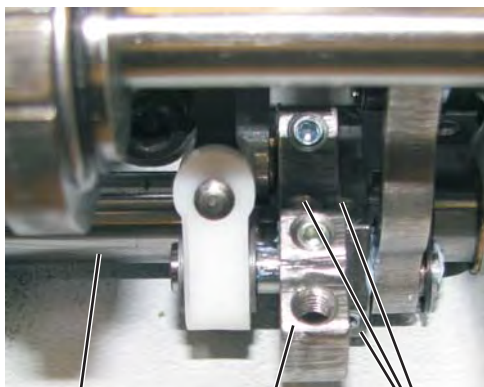

4

3

2

5

6



- Set the stitch length to "0".
- Loosen the screw (1).
- Loosen four screws (2) on the lever (3).
- Turn the shaft (4) so that the groove on its front side is in the vertical position.
- Tighten the screw (1).
- Unscrew the screw on the feed clutch (6) and insert the needle (5) into the hole left after it. Turn the clutch (6) with hand until the needle (5) fits 5 mm inwards. This fulfils the rule.
- Tighten the four screws (2).
- Remove the needle (5) and screw the screw back again.



Caution: Risk of injury!

Turn the main switch off.
Only carry out this adjustment when the machine is turned off.



ATTENTION: Danger of breakage!

With large stitch lengths, it is possible that parts within the clutch will collide if the middle working range of the clutch is not maintained.

2.4 Position of the eccentric tappet for the feed movement

Rule:

When the handwheel pointer indicates “0” degrees, the feed lever (1) should not move when the bartacking lever is pressed down.

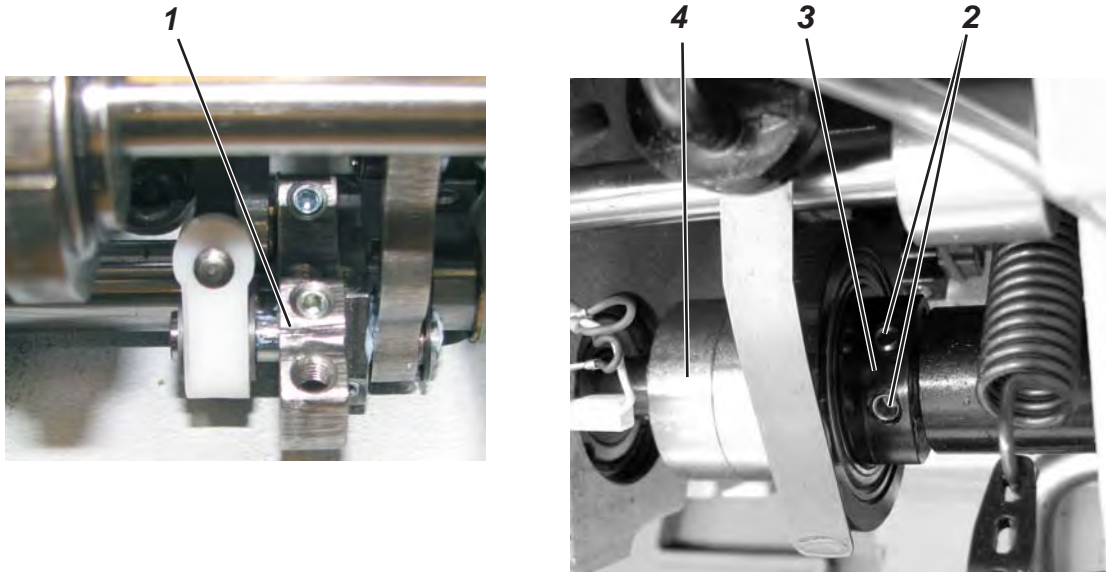

- Turn the handwheel so that the pointer indicates “0”.
- Loosen screws (2). To make the rough-scale adjustment, turn the eccentric tappet (3) so that it is approximately in the position shown in the illustration. Now make the fine-scale adjustment to the eccentric tappet. Continue until you have found the position where the feed lever (1) no longer moves when the bartacking lever is pressed down.
- Tighten screws at eccentric tappet (3).
- Fasten the weight (4) in the opposite position to the eccentric (3).



Caution: Risk of injury!

Turn the main switch off.

Only carry out this eccentric adjustment when the machine is turned off.



ATTENTION: Danger of breakage!

Imprecise settings can shorten the lifespan of the machine.

2.5 Switching over the feed clutch

Rule:

The clutch should be switched over when it is motionless (i.e., when it is in the dead centre point of its pendulum motion).

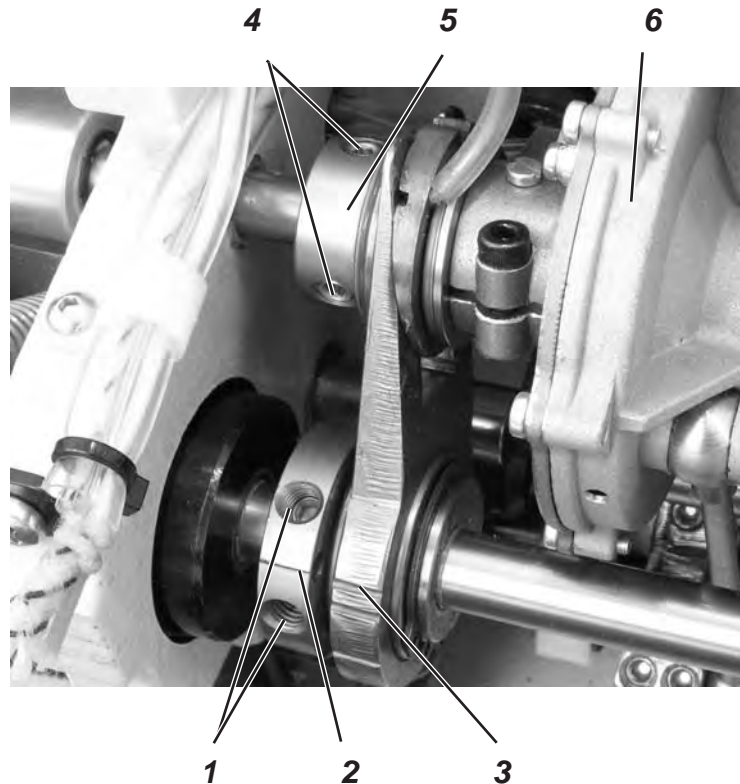

- Loosen the screws (1) on the eccentric tappet (2).
- Turn the eccentric tappet (2) so that the dash is aligned with the other dash (3).
- Loosen the three screws (4). Loosen the adjusting nut (5).
- Tighten the adjusting nut (5) until you feel it strike (the tightening increases in jumps). Push the clutch (6) to the right until the end stop is reached. Tighten the screws (4).
- Verify the adjustment. Turn the eccentric tappet with your hand in the other direction. The resistance during the rotation of the eccentric tappet should increase significantly when the two dashes are lined up.



Caution: Risk of injury!

Turn the main switch off.

Only carry out this adjustment when the machine is turned off.



ATTENTION: Danger of breakage!

Imprecise settings can shorten the lifespan of the machine.

2.6 Position of the eccentric tappet for the switch over of the feed clutch

Rule:

When the handwheel pointer indicates “313” on the scale, the dash (1) on the eccentric tappet should be lined up with the lower dash (2) on the V-shaped push rod.

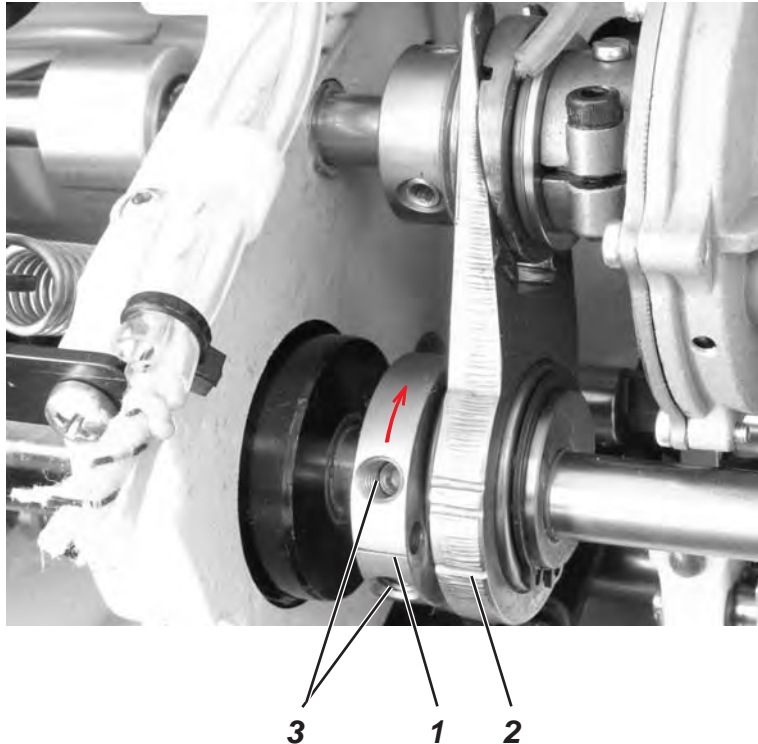

- Loosen screws (3).
- Turn the handwheel to position “313”.
- Turn the eccentric tappet in the direction of arrow so that dash (1) is lined up with dash (2).
- Turn back the eccentric tappet about 2° and move axially on the shaft until the middle is between the limit settings.
- Align the two dashes (1) and (2) again. Tighten the screws (3).



Caution: Risk of injury!

Turn the main switch off.

Only carry out this adjustment when the machine is turned off.

2.7 Checking the switch over of the feed clutch

Rule:

The feed clutch should be switched over when it is motionless (i.e., when it is in the dead centre point of its pendulum motion). This can be detected from the rotational direction of the belt pulley (1) in front of and behind the dead centre point.

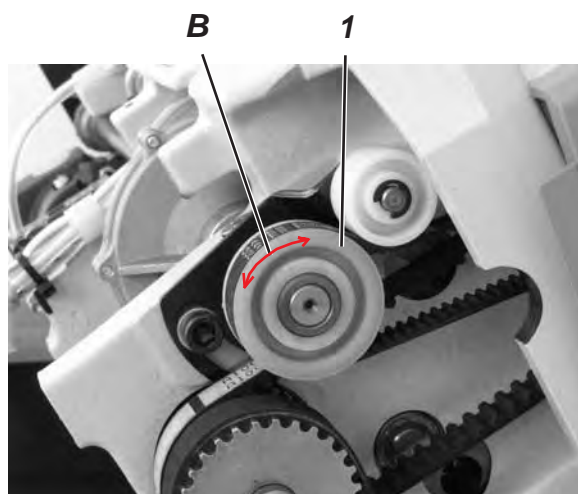

	1	2	3	4
A	274°	281°	94°	101°
B	←	→	←	→

- Set the maximum stitch length.
- Turn the handwheel (A) so that it is positioned at “274” degrees (refer to Table / A). Push the bartacking lever down. Check if the rotational direction (B) of the belt pulley (1) corresponds to the direction specified in the table. Do the same for “281” degrees.
- If the rotational directions do not correspond to those specified in the table, correct the necessary settings. If the clutch switches over too soon (on a smaller angle), tentatively loosen the adjusting nut (5) (see chapter 2.5) and repeat the check. Continue loosening until you locate the correct position for the nut. If the clutch switches over too late, tighten the controlling nut (5).



Caution: Risk of injury!

Turn the main switch off.

Only carry out this adjustment when the machine is turned off.



CAUTION!

Imprecise settings can shorten the lifespan of the machine.

2.8 Wheel feed

Rule:

1. The wheel feed elevation (**A**) over the throat plate insert should be adapted to the material thickness and hardness:

Soft or thick materials – **0.6 mm**

Thin materials – **0.2 mm**

2. The wheel feed knurling should be adapted to the sewn material character:

Soft material – the wheel feed with a crosswise knurling to suppress the prints on the material surface.

Thick material – the wheel feed with larger straight teeth.

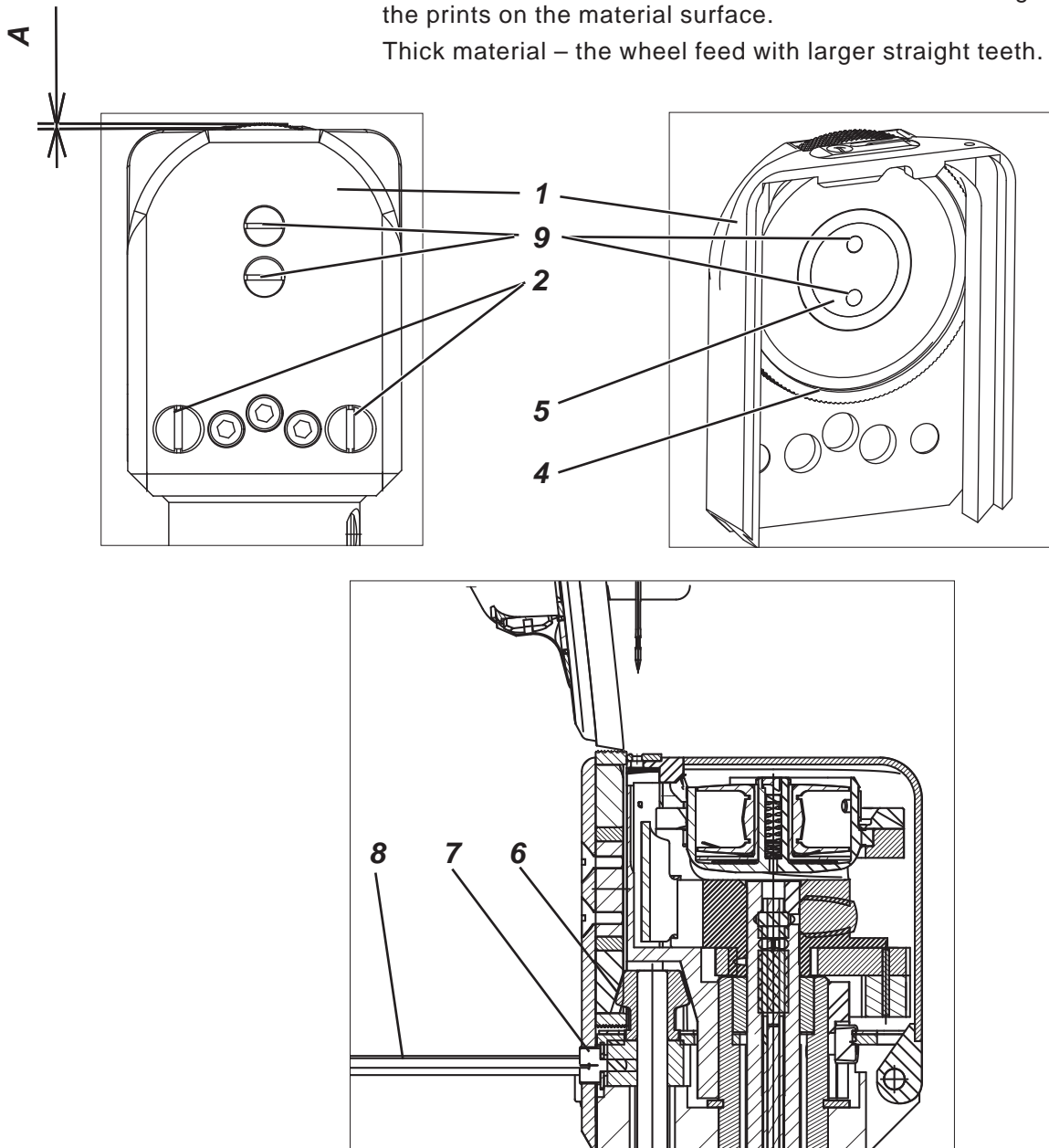

Wheel feed (A) elevation change

- Unscrew the screws (2) and dismantle the throat plate (1).
- Unscrew the screws (9).
- Turn the pin (5) with its upper side down.
- Screw the screws (9) on.
- Mount the throat plate (1) and screw the screws (2).

Wheel feed replacement

- Unscrew the screws (2) and dismantle the throat plate (1).
- Unscrew the screws (9).
- Slide the wheel feed (4) with the pin (5) downwards.
- Replace the wheel feed (4), slide the pin (5) inside and then slide them into the throat plate (1).
- Fix the pin (5) with the screws (9).
- Adjust the backlash of the teeth (6) with a setting screw (7) by means of a hexagonal key 2.5 mm (8).
- Tightening of the screw (7) reduces the backlash, and vice versa.
- Turn the hand wheel until the wheel feed turns by a whole revolution. When turning, check whether the wheel feed has a dead travel in all positions, which should be as small as possible.

3. Top feed

3.1 Position of the needle holder with single needle sewing machines

Rule:

The position of the needle holder is to be set according to the picture.

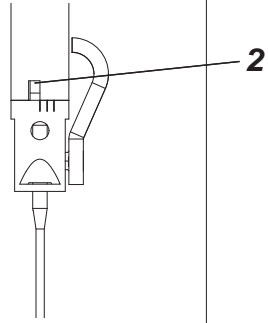
Angular position of the needle holder	
Needle thickness/Nm	70 - 110

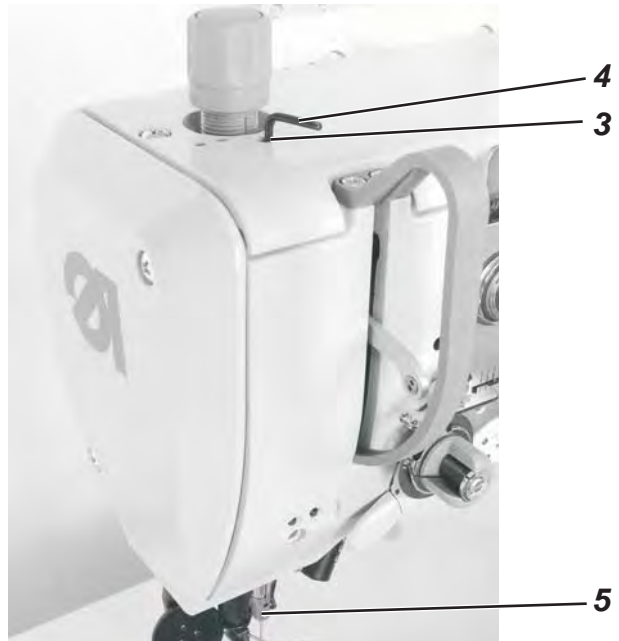

- Loosen screw (1) and turn the needle bar with the right groove edge (2) to the needle bar axis (in sewing direction) and tighten screw (1).
- Bring the needle bar to the upper dead center and loosen the screw of the needle holder through the bore (3) by using an Allen key of 2.5 mm (4).
- Turn the needle holder (5) according to the rule and tighten the screw.

3.2 Needle feed

Rule:

1. The needle bar should be laterally adjusted to flush with the presser bar.
2. The wheel feed holder should be laterally adjusted to make the clearance (A) approximately twice as wider than the clearance (B).
3. The feed movement of the needle should be set, so that, with maximum stitch lengths, the needle leaves the throat plate close to the backward edge of the stitch hole.

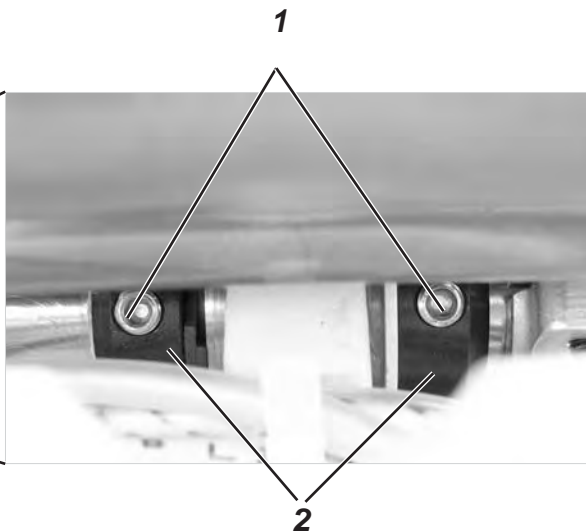
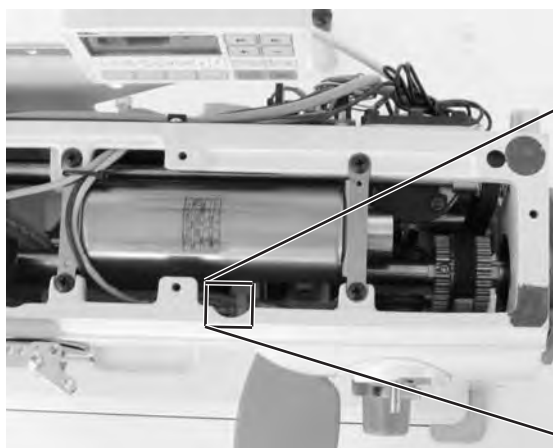
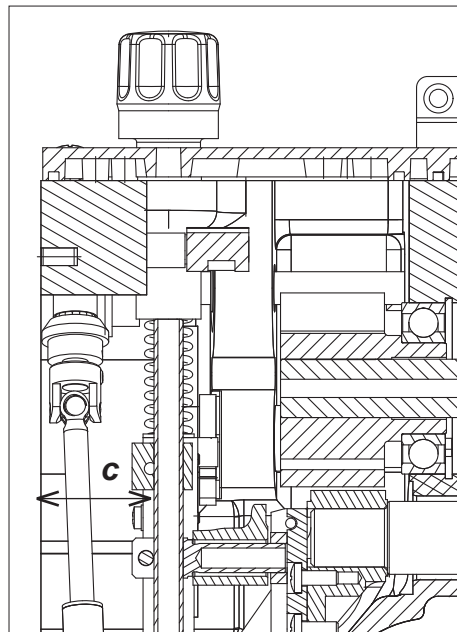
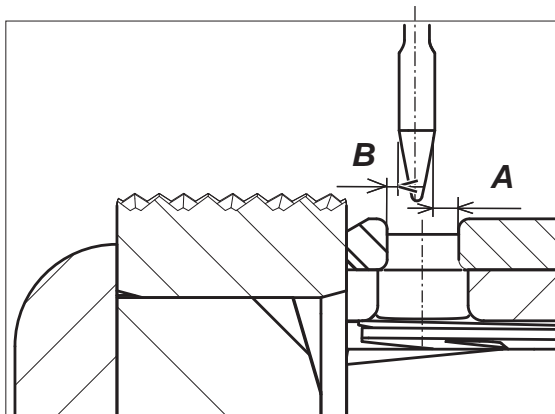

- Loosen screw (1) and set the needle bar to the measure (C) = 31mm as shown in the diagram. This procedure accomplishes rule 1.
- Set the adjustment rings (2) and tighten the screws (1).

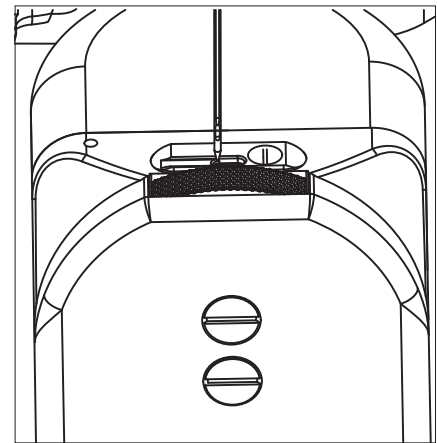
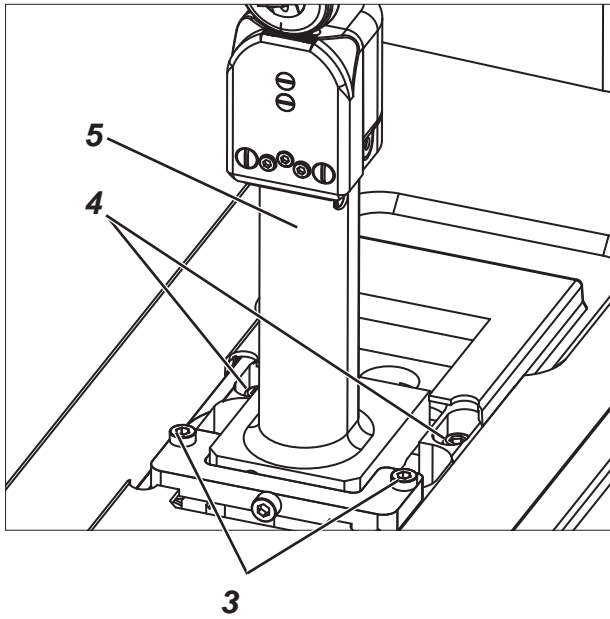
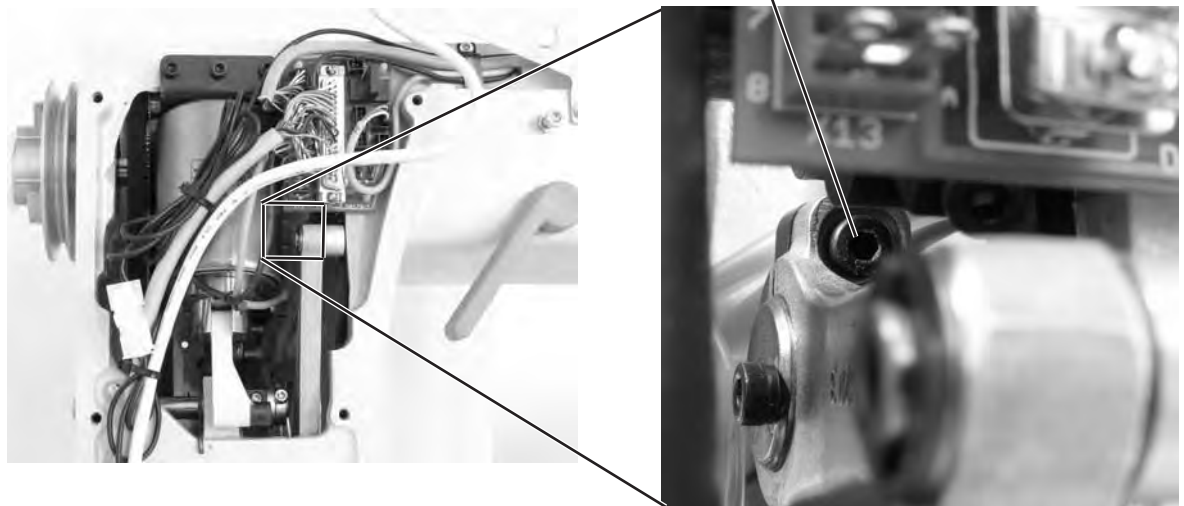

Fig. 1



- Loosen two screws (3) and the two screws (4). Displace the post bed feed (5) so that rule 2 is accomplished.
- Set the maximum stitch length as described in chapter 2.
- Set the needle to the position in which it leaves the throat plate insert. Dismantle the rear cover and loosen screw (6). Set the needle manually to the position shown in **fig. 1** and tighten screw (6).

3.3 Roller foot

Rule:

1. The location surface on the roller foot holder should be aligned in the right angle to the longitudinal axis of the machine.
Between the roller foot and the wheel feeder should be a distance of **(A) = 0,03 to 0,16 mm**.
2. The position of the roller foot in sewing direction should be set so that the distance **(B) = 1,3 to 2,3 mm**.
3. The lateral position of the roller foot should be set so that the lower edge of the roller foot ends with the left-hand edge of the stitch hole (8).

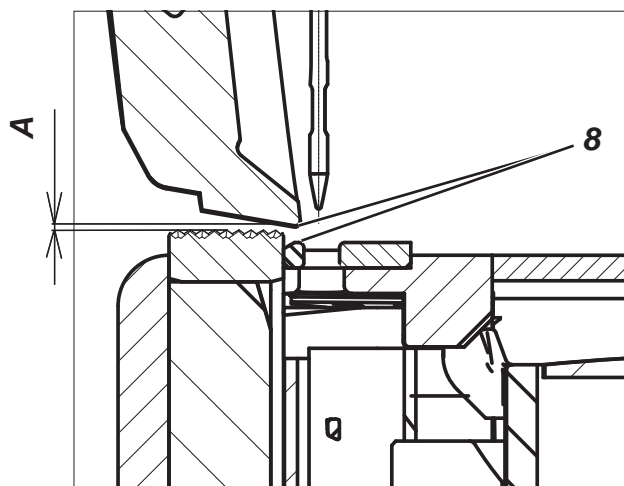
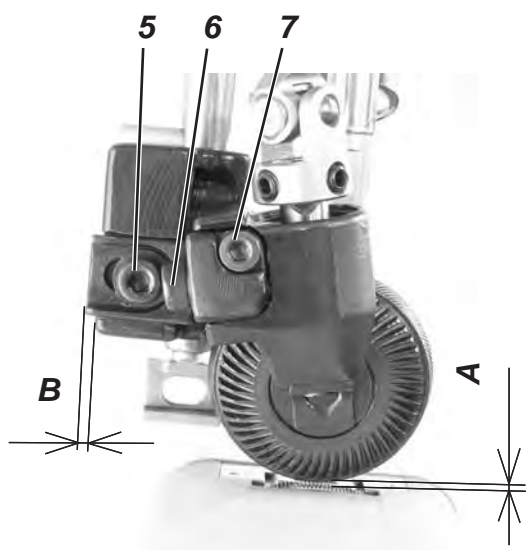
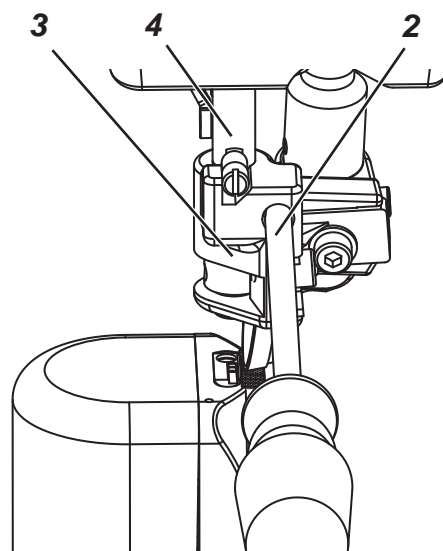
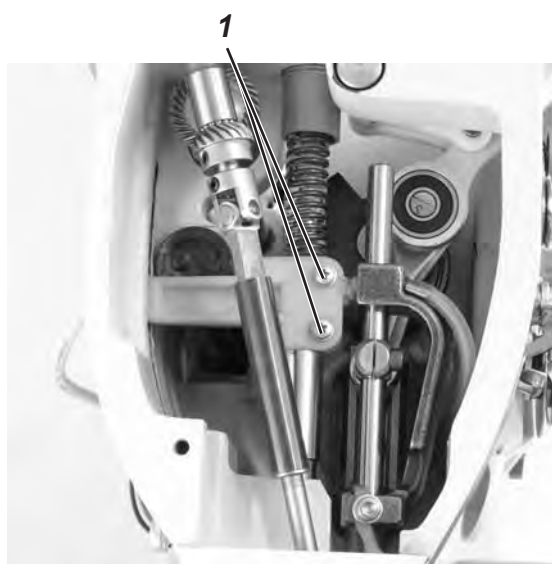

- Loosen screw (1). Displace the presser foot bar vertically according to rule 1. Insert the Philips screw-driver (2) that is part of the accessories into the hole of the roller foot holder (3) and turn the presser foot bar (4) together with the roller foot holder (3) until the Philips screw-driver comes to a right angle with the longitudinal axis of the machine. Tighten screw (1).
- Loosen screw (5). Displace the roller foot according to rule 2 and tighten screw (5).
- Loosen screw (6). Displace the roller foot according to rule 3 with the adjusting screw (7) and tighten screw (6).

3.4 Roller foot lifting

Rule:

1. The lifting of the roller foot via hand lever should be of **5.4 to 5.6 mm**.
2. The lifting of the roller foot via electromagnet should be of **11.5 to 12.5 mm**.
3. The lifting of the roller foot via knee lever should be of about **0.2 to 0.4 mm** higher than the electromagnetic lifting (if existing).

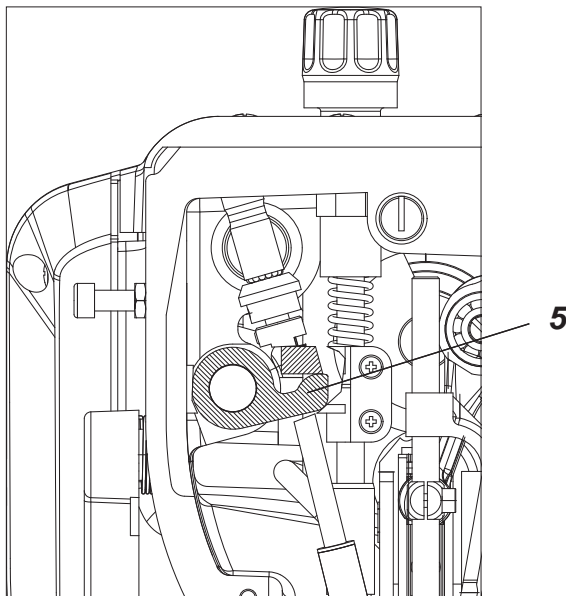
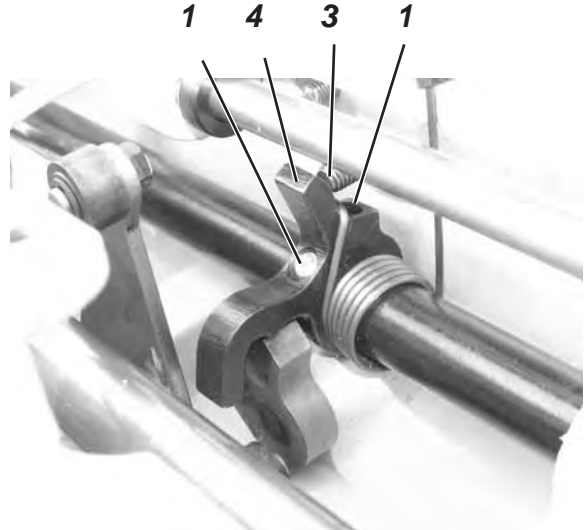
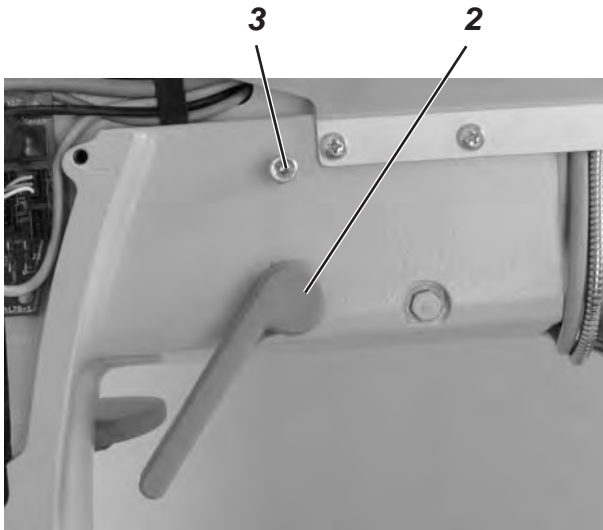

- Remove the solenoid of the presser foot lifting.
- Loosen screw (1). Bring the hand lever (2) into the depicted position and simultaneously screw in screw (3) until it butts against the lever (4). The lever (2) remains in the depicted position.
- Put a spacer of **5.6 mm** underneath the roller foot and push the lever (5) manually according to the figure above until it stops. Tighten screw (1). This procedure accomplishes rule 1.
- Remove screw (3) and mount the electromagnet of the presser foot lifting (6). In order to check whether rule 2 is accomplished, engage the magnetic core. If the values are not correct, effectuate an adjustment.
- Set the lifting of the knee lever according to rule 3 by adjusting screw (3).

EN

3.5 Variator of the roller foot drive

Rule:

1. With the correct position of the belt tensioner (1) the distance between the two cords of the V-belt should be **(A) = 1 to 2 mm**.
2. If the difference between upper and lower feed is set to zero on the setting nut (3), the graduation scale on the nut (4) should point exactly to "0".

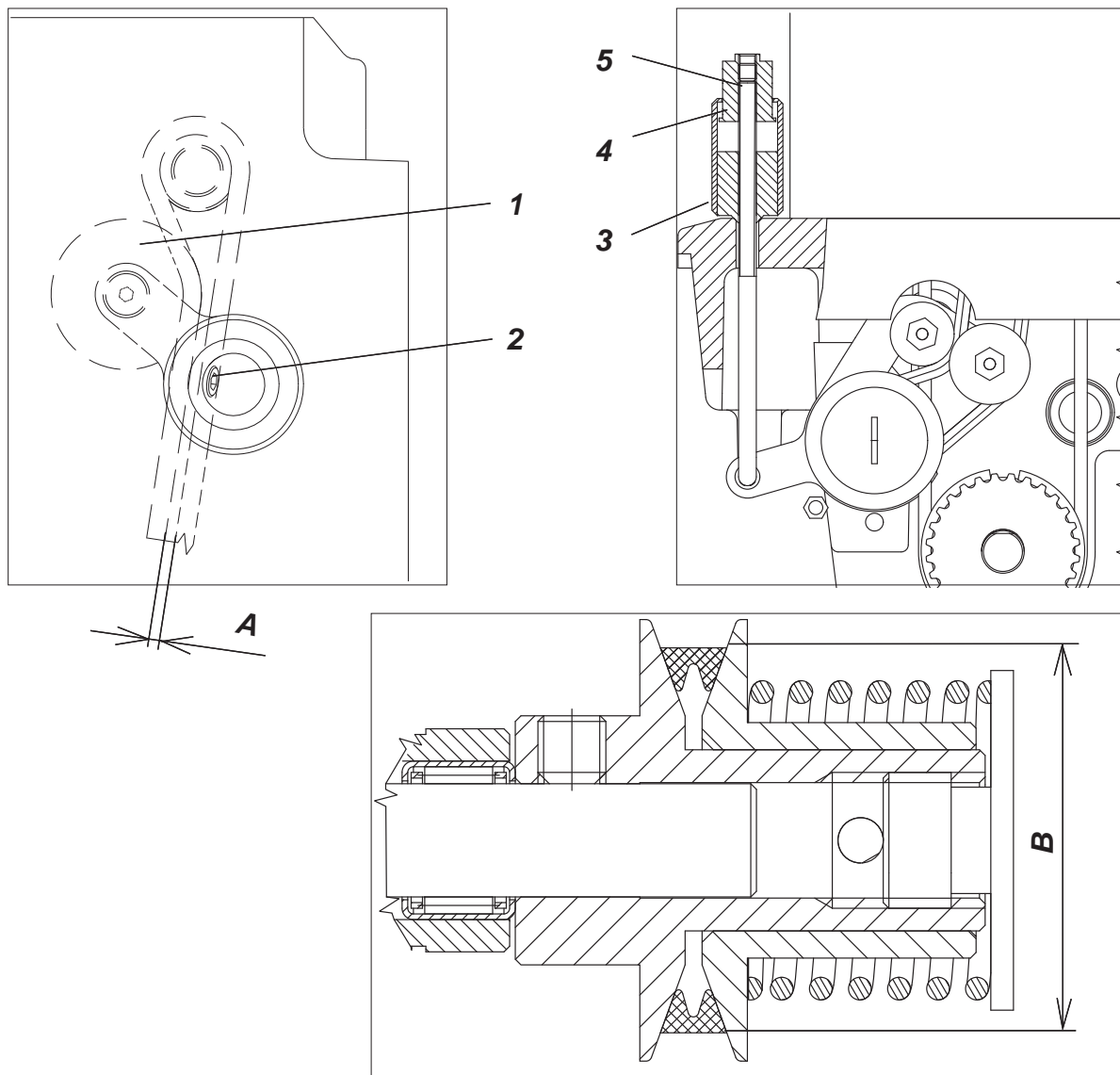

- Loosen screw (2) and position the belt tensioner roller (1) according to rule 1. Tighten screw (2).
- Set the diameter **(B) = 34 mm** by turning the setting nut (3).
- Make sure that there is no material displacement between upper and lower feed. Sew two narrow strips of sewing material of about 30 cm together. If the strips after sewing are vaulted upward or downward, this indicates a difference between upper and lower feed. The position of the setting nut (3) must be adjusted accordingly.
- After reaching the point of "zero difference", the graduation scale on the nut (4) must be adjusted. Turn the nut (4) until the third line of the scale is on the upper edge of the the nut (3). This marks the zero position.
- Secure the nut (4) with screw (5).

4. Setting of the needle bar and of the hook

4.1 Hook height

Rule:

The distance **A** should be 1.0 up to 1.1 mm.

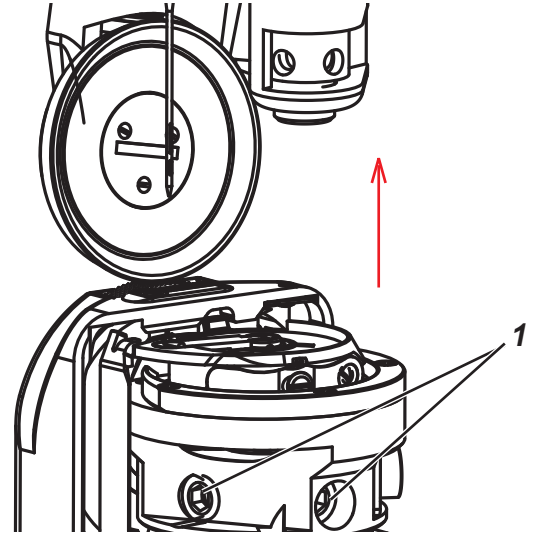
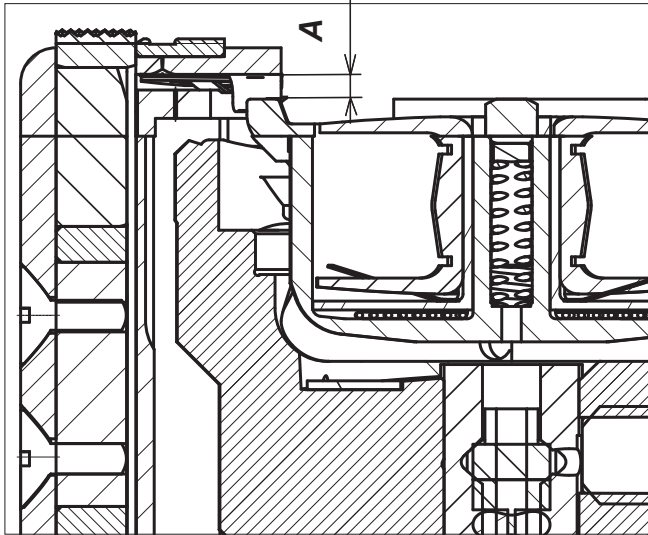

- Loosen screws (1) and set the height (**A**) according to the rule.
- Tighten the screws (1).



Caution: Danger of injury !

Turn the main switch off.

Proceed with the hook setting only with the sewing machine switched off.

EN

4.2 Needle bar height, play of needle to hook tip, loop stroke

Rule:

When the handwheel pointer indicates "205" degrees (2.3 mm loop stroke), the hook tip should stand at the needle axis at the stitch length "0". Length (A) = 1.5 mm, distance (B) = 0.02 to 0.1 mm.

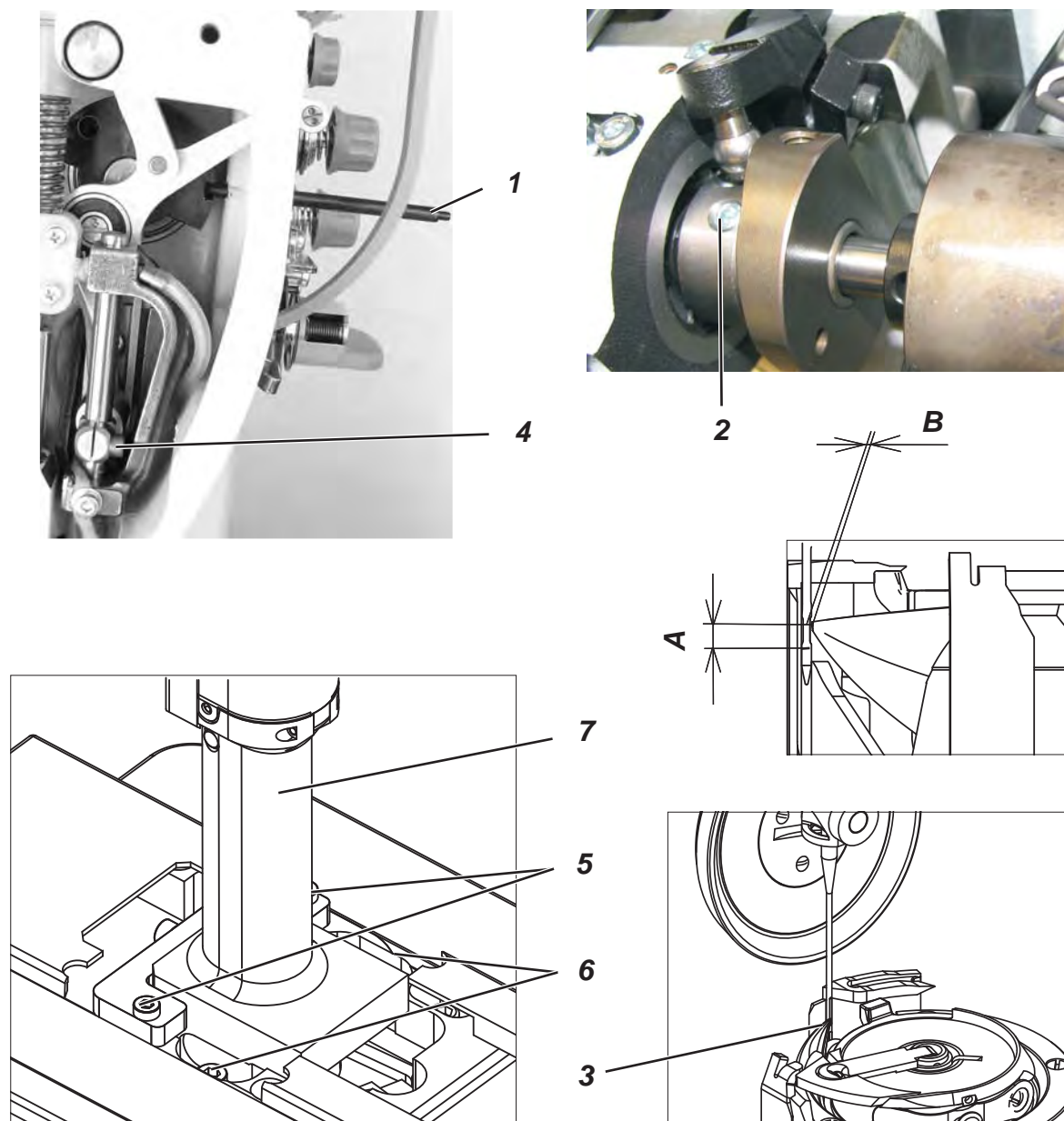

- Lock the handwheel in loop stroke position (2.3 mm) by using the locking pin (1) 5 mm, degree "205".
- Loosen four screws (2) and turn the hook tip (3) to the needle axis.
- Loosen screw (4), position the needle bar and needle to the distance measure (A) and tighten screw (4).
- Loosen the two screws (5) and screws (6) and displace the hook column (7) from off the needle to the distance measure (B). Tighten screws (5) and (6).
- Check whether the hook tip (3) is positioned in the range of the needle axis, tighten screw (2)

4.3 Hook tip guard

Rule:

The guard plate of the hook (1) should prevent a contact between the needle and the hook tip (2).

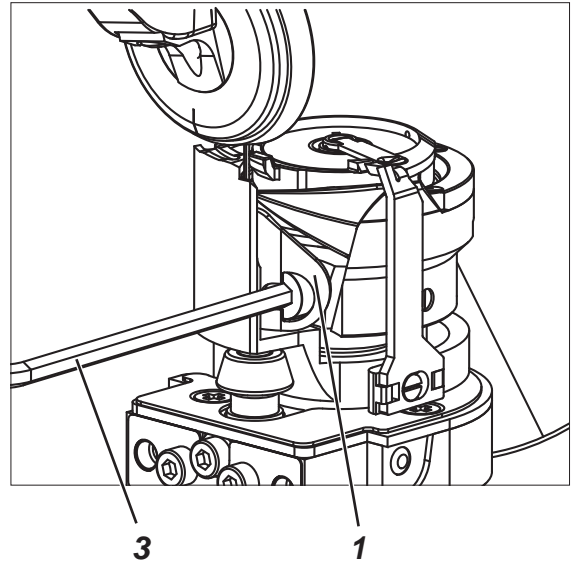
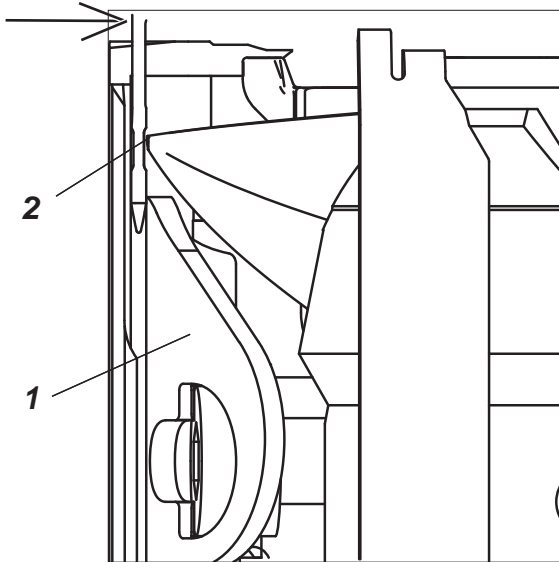

- Set the maximum stitch length according to the sewing equipment.
- Dismount the throat plate.
- Position the hook tip (2) on the needle and adjust the setting screw of the guard plate (1) by using an Allen key of 3 mm (3), so that the needle does not touch the hook tip (2).
- Checking: Exert a light pressure on the needle (see arrow) and turn the hook at the same time.
- The setting is not incorrect if the guard plate (1) slightly deflects the needle.



Caution: Danger of injury !

Turn the main switch off.

Proceed with the setting of the hook guard and loop former only with the sewing machine switched off.

4.4 Bobbin housing release

Rule:

The distance measure (A) with max. release should be 0,5 mm.

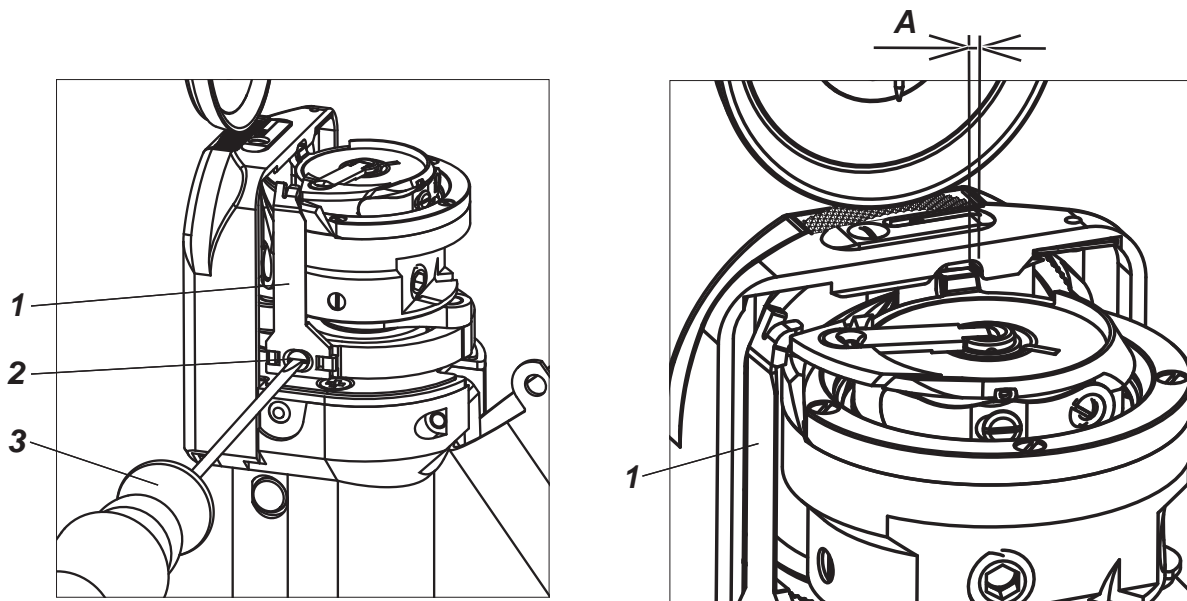

- Set the degree "310" on the scale of the handwheel.
- Loosen screw (2) by the screwdriver (3), set the bobbin housing release (1) so that the distance measure (A) according to rule 2 is accomplished.
- Tighten screw (2).

4.5 Hook lubrication

Rule:

The screw (2) is to be unscrewed by 1.5 revolution from the position where the lubrication is fully closed.

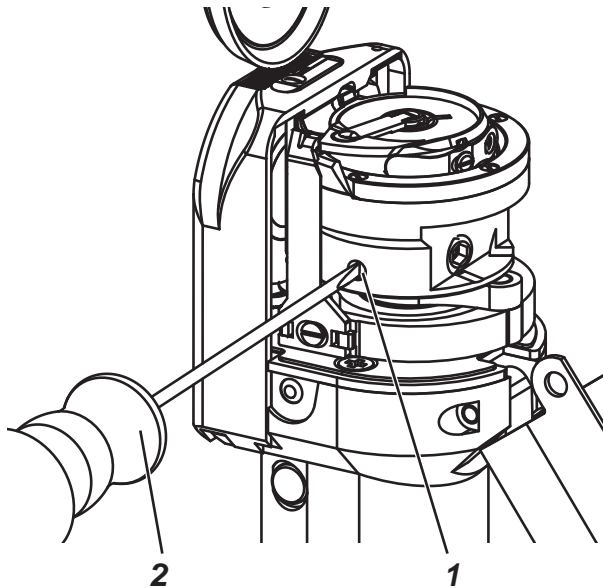

- Screw the choking screw (1) by means of a screwdriver (2) and loosen it back by 1.5 revolution according to the rule.
- Check whether the oil lubrication is sufficient. Place a sheet of paper near the hook, run the machine to full speed and observe whether a trace of sprinkling oil appears on the paper.
- If you want to choke the lubrication, screw the screw (1) deeper, and vice versa.



Caution: Danger of injury !

Turn the main switch off.

Proceed with the setting of the hook lubrication only with the sewing machine switched off.

5. Thread setting

5.1 Thread regulator, check spring, bolt for the thread lever mechanism

Rule:

1. The right edge of the thread regulator (1) should end at figure 2 on the scale.
2. The check spring (5) should be set to the distance measure of **(A) = 15 mm**. The spring travel consists of about **30°**.
3. The slot position of the bolt (8) should form an angle **30°** on the left from vertical.

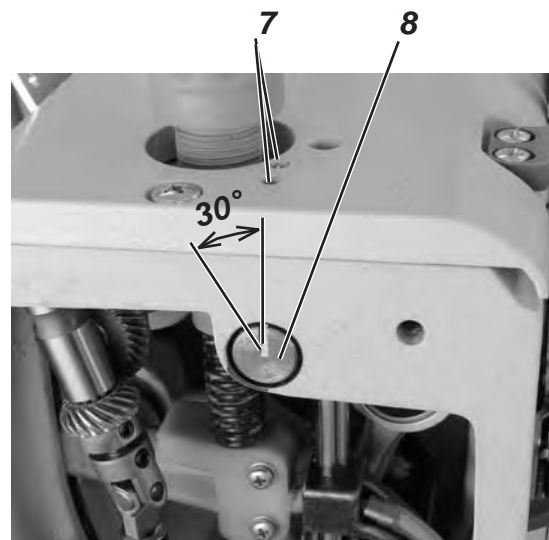
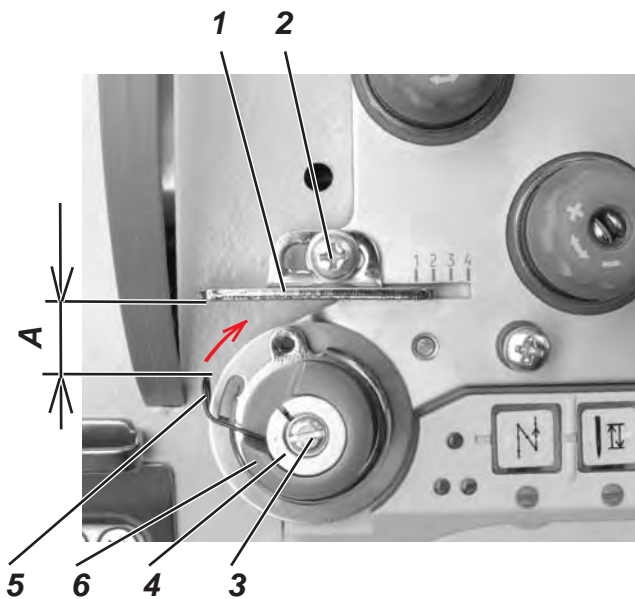

- Loosen screw (2), push the thread regulator (1) according to rule 1 to end at figure 2, tighten screw (2).
- Loosen screw (3). Turn the stop sleeve (4) in the direction of the arrow until the check spring (5) comes off the body (6). Turn the stop sleeve (4) against the direction of the arrow until the check spring (5) touches the body (6). Turn both parts (4) and (6) together to reach the distance measure **(A)**. Detain the body (6) and turn the stop sleeve (4) for another **30°** against the arrow. Detain the parts (4) and (6), tighten screw (3).
- Insert a 3 mm Allen key in the holes (7) and loosen the screws. Bring the bolt (8) into the correct position according to rule 3 and tighten screws (7).

5.2 Bobbin winder

Rule:

1. When the bobbin winder is switched off, the distance between bobbin winder wheel and belt pulley should be **(A) = 0.8 mm**.
2. The winding procedure should stop automatically, when the bobbin is filled up to **0.5 mm** underneath the the bobbin edge.

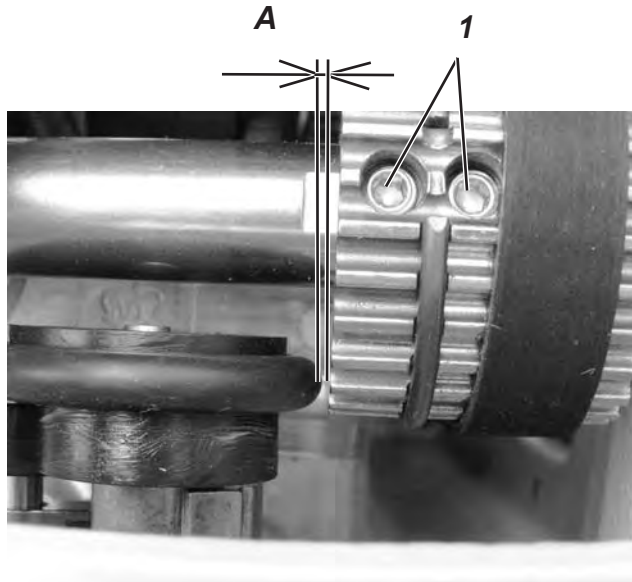

- Turn the belt pulley to the top using the screws (1). Push the toothed belt to the right so that both screws (1) are accessible. Loosen screws (1) and set the distance measure **(A)** according to rule 1, tighten screws (1).
- Determine the bobbin filling by adjusting screw (2). Screw in screw (2) for 1 to 2 mm, but a bobbin on the bobbin winder shaft and wind on thread. Check the filling level as soon as the bobbin winder turns off. If necessary, change the position of the screw (2) until rule 2 is fulfilled.

6. Thread cutter

6.1 Thread-pulling knife height

Rule:

At the turning to its adjusting position the thread-pulling knife (1) should touch the counter knife (3) without pressure.

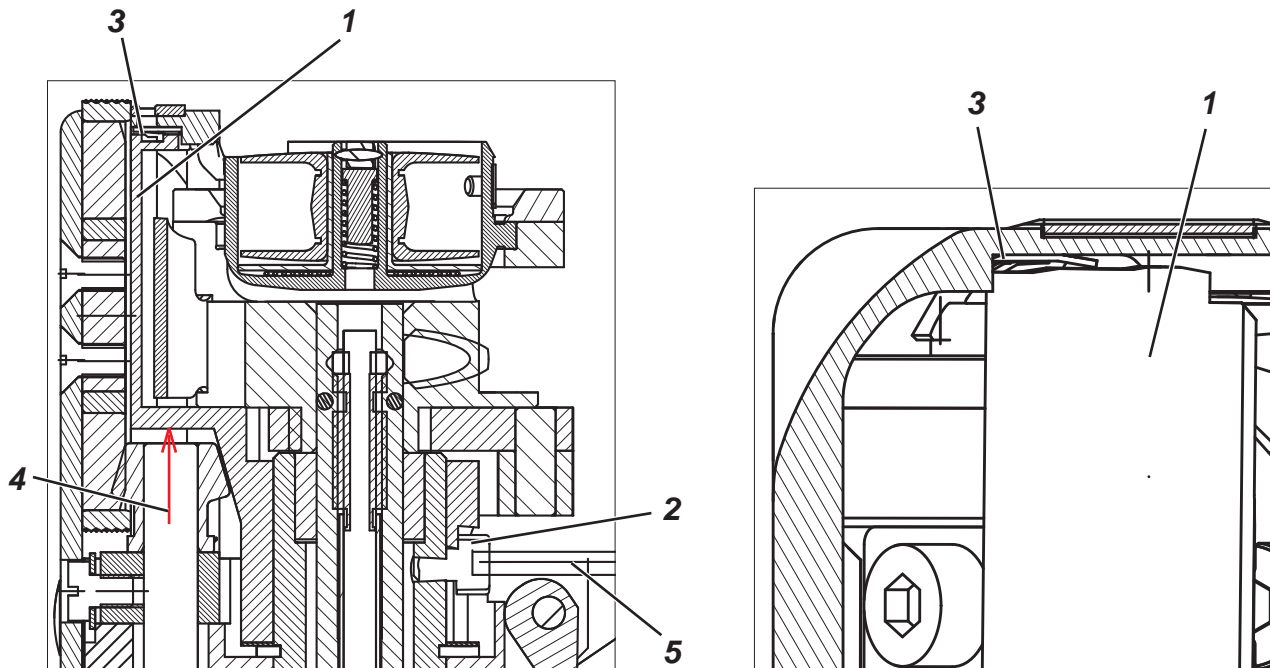

- Slightly turn the thread-pulling knife (1) so that its locking screw (2) is accessible for the hexagonal key 2.5 mm (5).
- Loosen the screw (2) and lift the thread-pulling knife (1) in the arrow (4) direction to touch the counter knife (3). The thread-pulling knife must not develop any pressure on the counter knife (3). The cutting pressure between the knives (1) and (3) will develop during the thread-pulling knife (1) slight turning to the cutting position due to the elevated position of its cutting edge surface.
- Fix the thread-pulling (5) with the screw (2).



Caution: Danger of injury !

Turn the main switch off.

Proceed with the thread cutter setting only with the sewing machine switched off.



Attention!

When the pressure of the counter knife is set too high this results in a higher knife wear.

6.2 Starting position of the thread-pulling knife

Rule:

If the thread-pulling knife (1) is locked in the starting position with a needle shank (2), the electric motor shock absorber (4) and the lever (3) should be positioned at the stop.

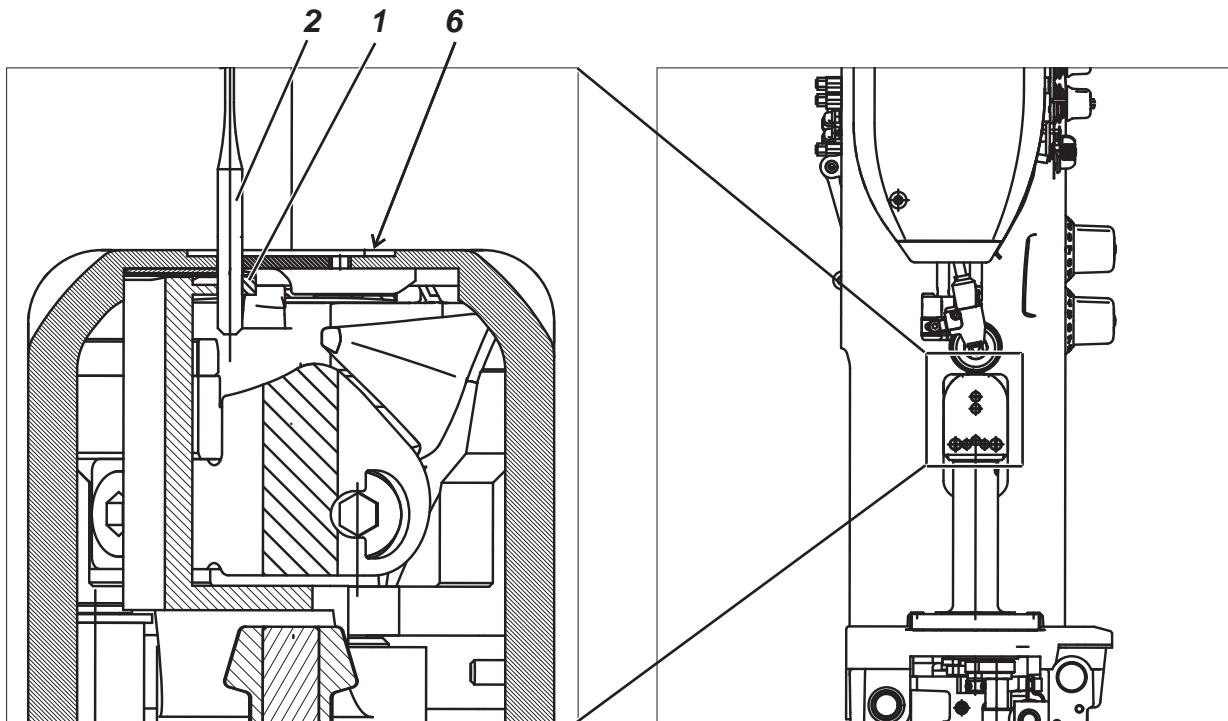

- Dismantle the throat plate insert in the recess (6).
- Loosen the screw (5) with the hexagonal key 3 mm.
- With your hand slightly turn the thread-pulling knife (1) to the starting position and lock it with the needle shank (2).
- Turn the lever (3) in the arrow direction to the stop and then fix it with the screw (5).
- Remove the needle (2) and mount the throat plate insert back again.



Caution: Danger of injury !

Turn the main switch off.

Proceed with the thread cutter setting only with the sewing machine switched off.

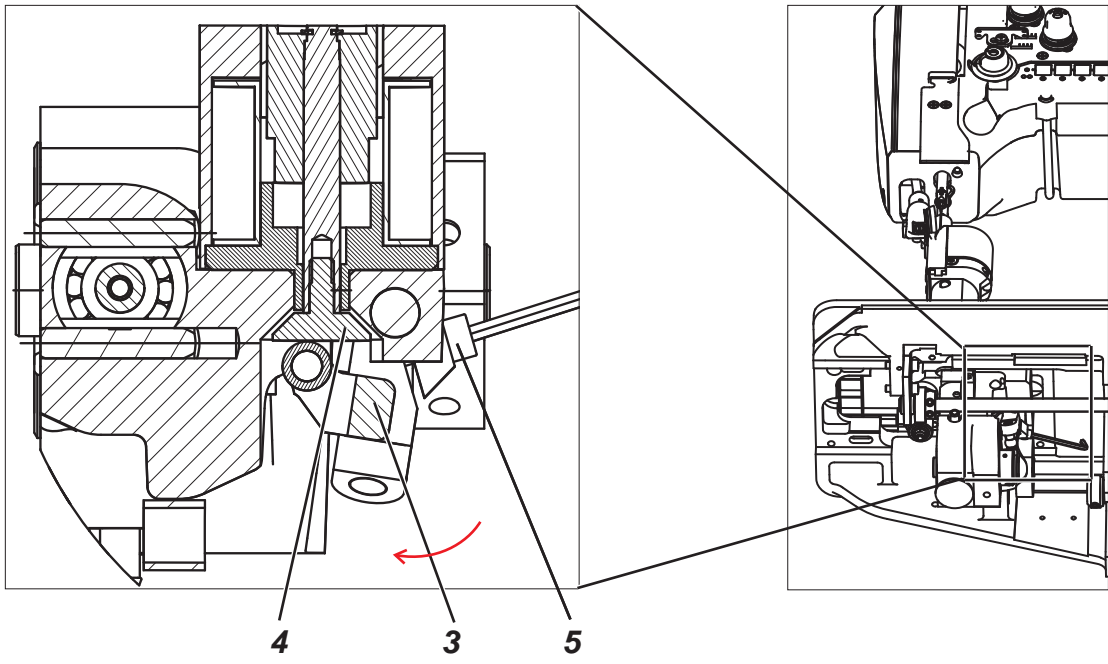

6.3 Angle position (timing) of control cam and clearance between cam and roller

Rule:

If the control cam (3) is locked with the pin (1) according to the picture:

1. On the hand wheel there should be the angle **100°**.
2. Between the control cam (3) and the roller (4) there should be the distance **(A) = 0,1 mm**.

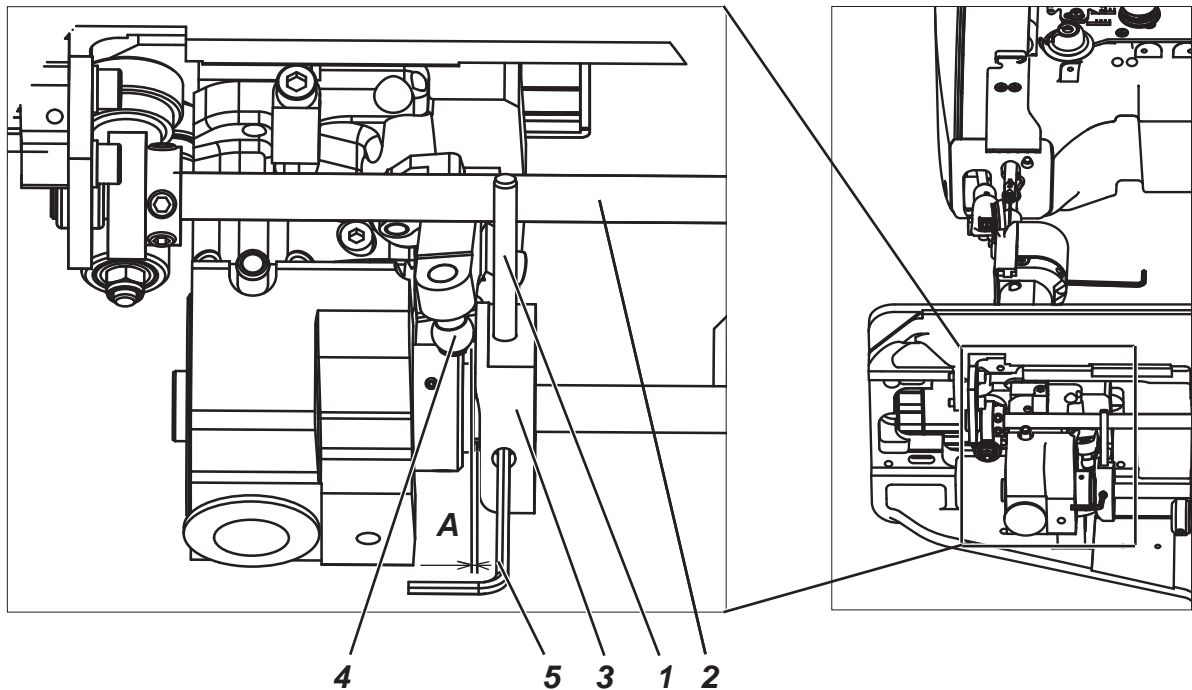

- Loosen both locking screws of the cam (3) with the hexagonal key 3 mm (5).
- Slightly turn the hand wheel to the angle **100°**.
- Insert the locking pin (1) according to the picture and lean it against the shaft (2).
- Insert the feeler gauge **0.1 mm** between the cam (3) and the roller (4).
- Slide the cam (3) to the left fully to the stop until the clearances inside the mechanism are set.
- Fix the cam (3) with one locking screw with the key (5).
- Remove the pin (1) and tighten also the other locking screw of the cam (3).



Caution: Risk of injury!

Turn the main switch off.

Proceed with the setting of the control cam only with the sewing machine switched off.

6.4 Bobbin thread clamp

Rule:

The clamping force of the spring (1) should be high enough so as the tension needed to pull out the bottom thread is approximately the same as the tension needed to pull this thread from the hook bobbin.

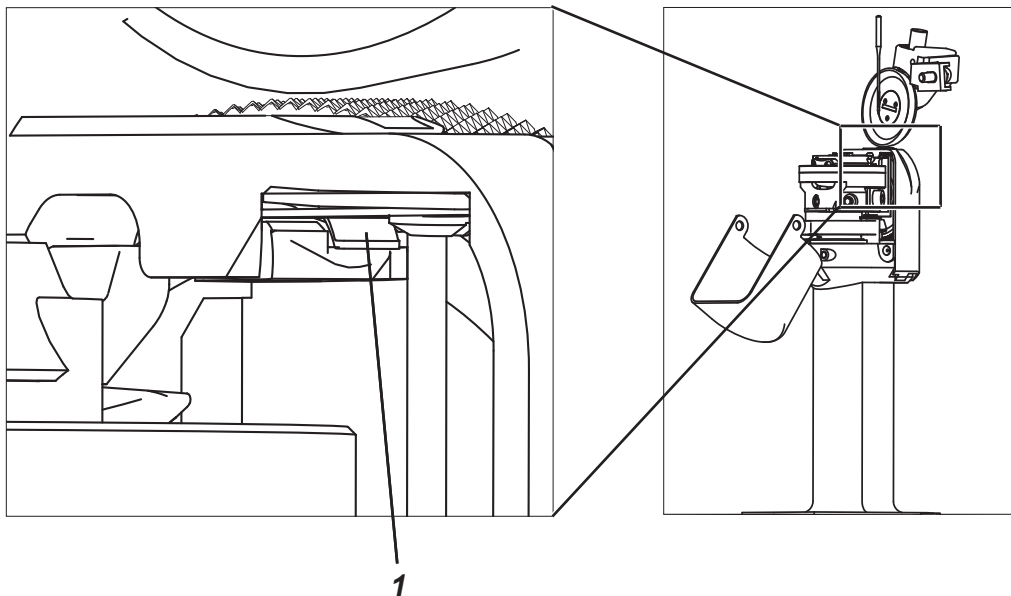

- Sew and cut the threads.
- Pull the bottom thread. If its tension is too low (the thread under the spring can easily slip out), turn the hand wheel to the angle 290°, tilt the hook cover up and slightly bend the spring (1) downwards with a screwdriver.
- Repeat the seam sewing, do the thread cutting, perform a test of the tension needed to pull the thread out, and slightly bend the spring, until the thread is reliably retained with the spring.



Caution: Risk of injury!

Turn the main switch off.

Only adjust the clamping spring when the machine is turned off.



CAUTION!

Sewing problems can result when the clamping spring is improperly adjusted.

7 Electronic control and sewing machine drive - positioning motor

All operating instructions and parameter sheets are available at the manufacturers' websites (see www.efka.net, www.duerkopp-adler.com, www.hohsing.com, etc.).

Selected instructions concerning the control and drive setting needed for the operators are included in the Operating instructions.

Selected instructions needed for the technician to set the drive are included in the Operating instructions.

Important notes concerning electrostatic discharges (ESD)



Caution!

Before effectuating any works on electronic components: Turn off the main switch. Remove the plug from the socket.

EN

Electrostatic discharges can cause damage to PCBs and other components. You can obtain a certain protection by wearing anti-static gloves or wrist-wraps that you can connect for grounding on the mass of any unpainted metal piece of the machine head or on the switch cabinet.

Handle the PCBs with utmost caution. They are very sensitive towards electrostatic discharges. Hold the PCBs only at their edges.

Put the PCBs after unwrapping or after dismantling with their components upside onto a grounded statically discharged surface. We recommend to use a conductive foam underlay but not as the protective cover of the PCB.

Pay attention not to pull the PCBs over any surface.

7.1 Terminals to PCB connections - electromagnetic variant

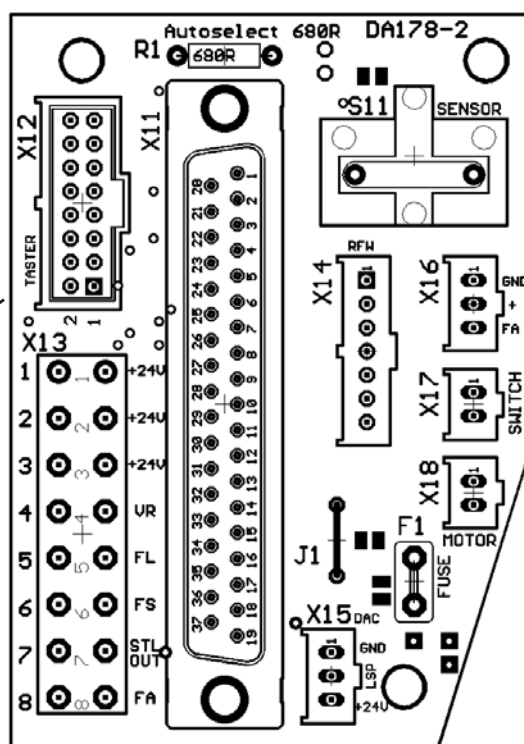
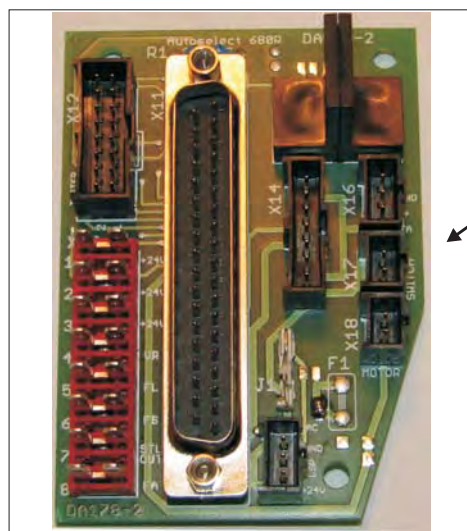

Description of DA178-2 (9850 688001) switchboard connection

X11 - main connection cable to control unit

X12 - keypad (Taster)

X13 - terminals for solenoid connection

1,2,3 – supply voltage +24V

4 - VR (backtacking)

5 - FL (foot lifting)

6 - FS (thread tensioner)

7 - STL OUT (half stitch)

8 - FA (thread trimmer)

X14 - bobbin thread monitor

X15 - connection of side switchboard when using DAC control
(with cable 9870 867018)

X16* - connection of connecting cable 9870 688002 for connector on base plate
(thread trimmer solenoids, sewn material edge horizontal trimmer)

X17 - microswitch of sewn material edge trimmer (vertical, oblique)

X18 - sewn material edge trimmer motor

F1 - sewn material edge trimmer resettable fuse

R1 - Autoselect resistor (sewing machine class selection)

S11 - tilt sensor

J1 - switch; if the sewing machine has a direct drive (DAC control, side switchboard), switch J1 off, otherwise switch J1 on.

* Connection of edge trimmer solenoids to the grey connector on the base plate is to be made between FA and + (white and brown).

Connection of the horizontal edge trimmer is to be made between + and GND (brown and green).

7.2 Terminals to PCB connections - pneumatic variant

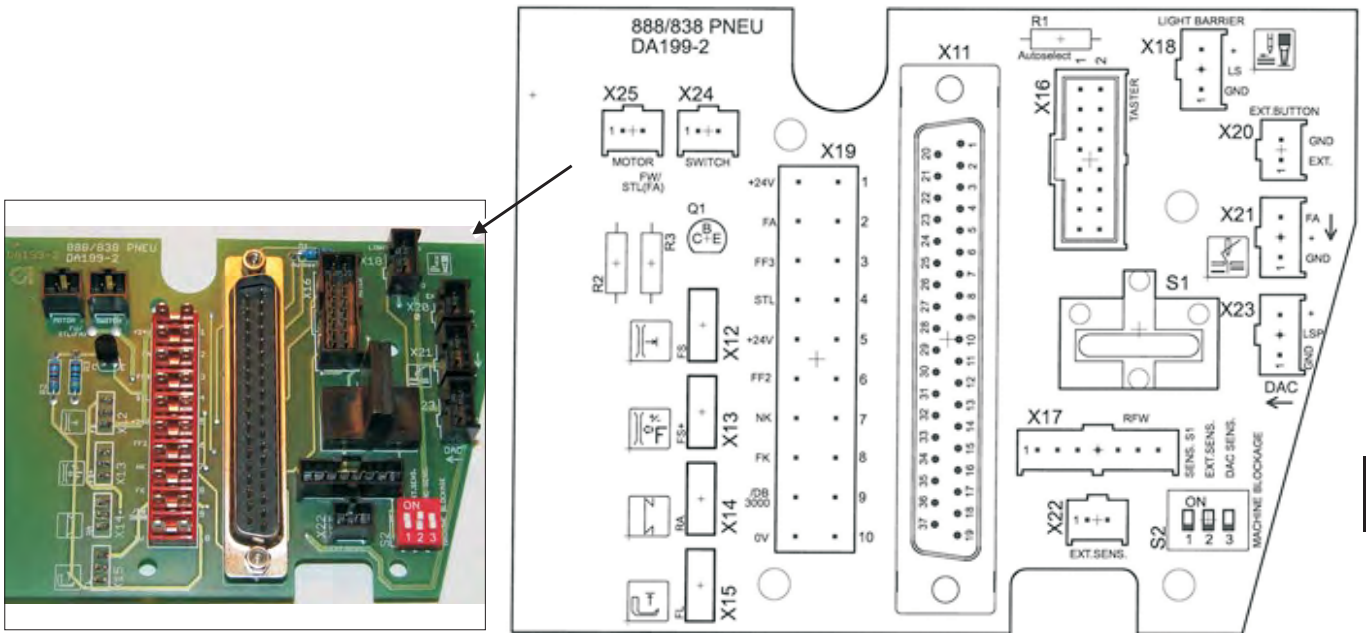

Description of DA199_2 (9850 838000) switchboard

- X11 - 37-pole connector (to control box)
- X12 - thread tensioner valve
- X13 - secondary thread tensioner valve
- X14 - bartacking valve
- X15 - sewing foot valve
- X16 - keypad
- X17 - bobbin thread monitor
- X18 - light barrier
- X19 - 1. +24V
2. FA (thread trimming)
3. FF3 (functional outlet 3, e. g. puller, pneumatic material edge trimmer)
4. STL (stitch length valve)
5. +24V
6. FF2 (functional outlet 2)
7. NK (needle cooling)
8. FK (thread clamp)
9. /DB3000 (needle switch off)
10. 0V
- FW/STL(FA) – auxiliary outlet (thread wiper/zero stitch length at thread trimming)
- X20 - external outlet controlled with auxiliary pushbutton on keypad ($I_{max}=50mA$)
- X21 - connection of auxiliary cable for bottom distribution (FA, +24V, GND)
- X22 - external blocking of operation (e. g. thread lever guard switch, etc.)
- X23 - connection of a side DAC switchboard (direct drive)
- X24 - material edge trimmer microswitch
- X25 - material edge trimmer mini motor
- S1 - tilt sensor
- S2 - sewing machine operation blocking mode; switch in ON position means that the sensor is without function
- SENS. S1 = tilt sensor on switchboard; EXT.SENS. = sensor in connector X22
- DAC SENS. = sensor on DAC side switchboard (direct drive)

EN



DÜRKOPP ADLER GmbH
Potsdamer Str. 190
33719 Bielefeld
Germany
Phone +49 (0) 521 925 00
E-Mail: service@duerkopp-adler.com
www.duerkopp-adler.com