



Integrated motor Additional manual

All rights reserved.

Property of Dürkopp Adler AG and protected by copyright. Any reuse of these contents, including extracts, is prohibited without the prior written approval of Dürkopp Adler AG.

Copyright © Dürkopp Adler AG - 2014

1	Safety information	3
2	Overview of the components.....	5
3	Disassembling the drive	6
4	Assembling the drive	9

1 Safety information

DANGER



Risk of injury from electricity.

Unprotected contact with electricity can result in serious injuries or death.

Work on the electrical system must **ONLY** be performed by qualified electricians or appropriately trained and authorized personnel.

ALWAYS unplug the power plug before working on the electrical equipment.

WARNING



Risk of injury.

The machine may only be disassembled and assembled by trained specialists.

2 Overview of the components

Figure 1: Overview of the components

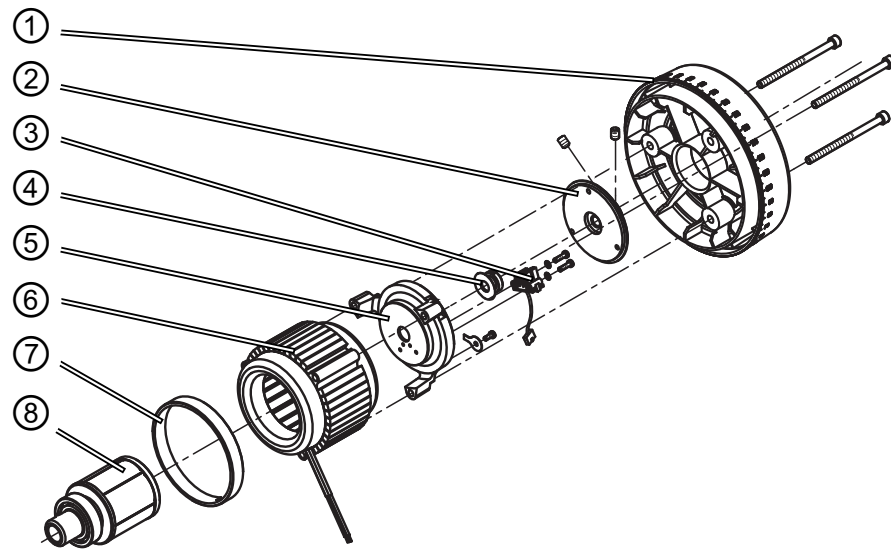

- (1) - Handwheel
- (2) - Handwheel flange
- (3) - Encoder
- (4) - Encoder disc

- (5) - Cover plate
- (6) - Stator
- (7) - Ring
- (8) - Rotor

3 Disassembling the drive

Removing the handwheel and handwheel flange

Figure 2: Removing the handwheel and handwheel flange



(1) - Handwheel
(2) - Screws

(3) - Setscrews
(4) - Handwheel flange



1. Undo all three screws (2) on the handwheel (1).
2. Undo both setscrews (3) and remove the handwheel flange (4).

Removing the cover

Figure 3: Removing the cover

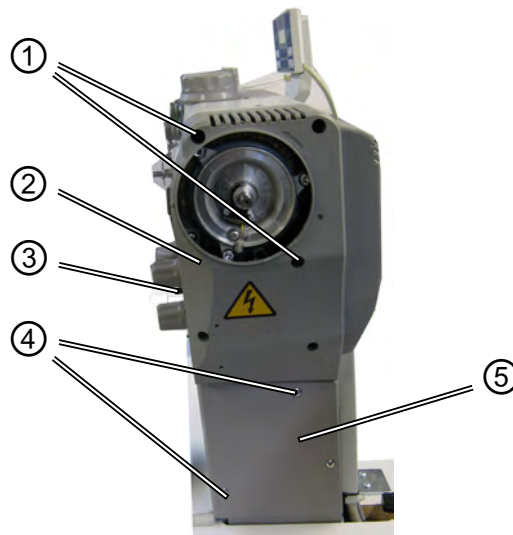

(1) - Screws
(2) - Upper cover
(3) - Dial

(4) - Screws
(5) - Lower cover (depending on machine)



1. Undo all five screws (1).
2. Carefully remove the upper cover (2) from the side, paying attention to the dial (3) in doing so.

3. If there is a lower cover mounted: Undo all three screws (4) and remove the lower cover (5).

Removing the encoder

Figure 4: Removing the encoder

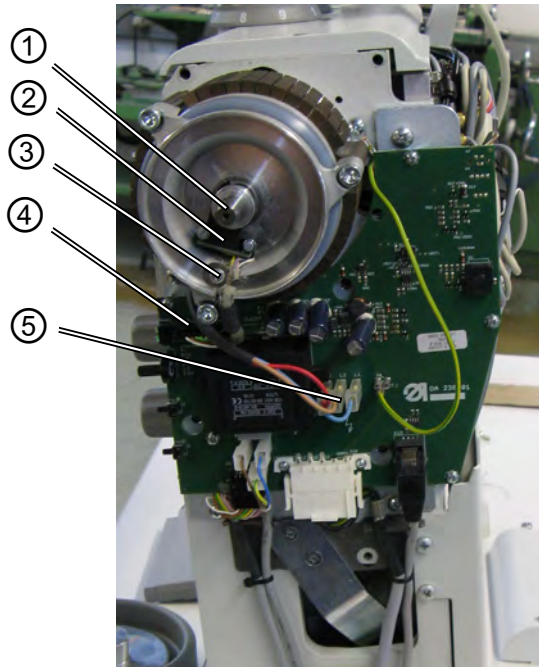

(1) - Encoder disc
(2) - Encoder
(3) - Retaining plate

(4) - Encoder plug
(5) - Plugs L1, L2, L3



1. Disconnect plugs L1, L2, and L3 (5).
2. Disconnect the encoder plug (4).
3. Unscrew the retaining plate (3).
4. Undo both screws for the encoder (2).
5. Undo the screw for the encoder disc (1).
6. Carefully and uniformly pull the encoder (2) and encoder disc (1) away from the shaft.

Removing the stator *Figure 5: Removing the stator*

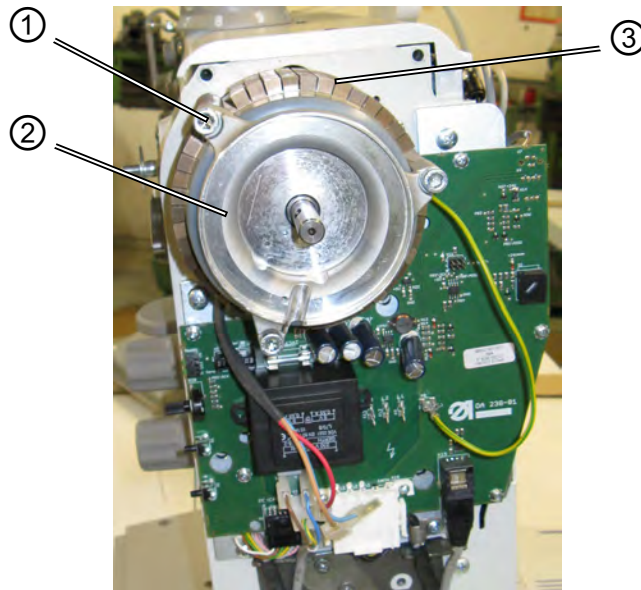

(1) - Screws

(2) - Cover plate

(3) - Stator with ring



1. Undo all three screws (1).
2. Remove the cover plate (2).
3. Remove the stator with ring (3).

Removing the rotor *Figure 6: Removing the rotor*

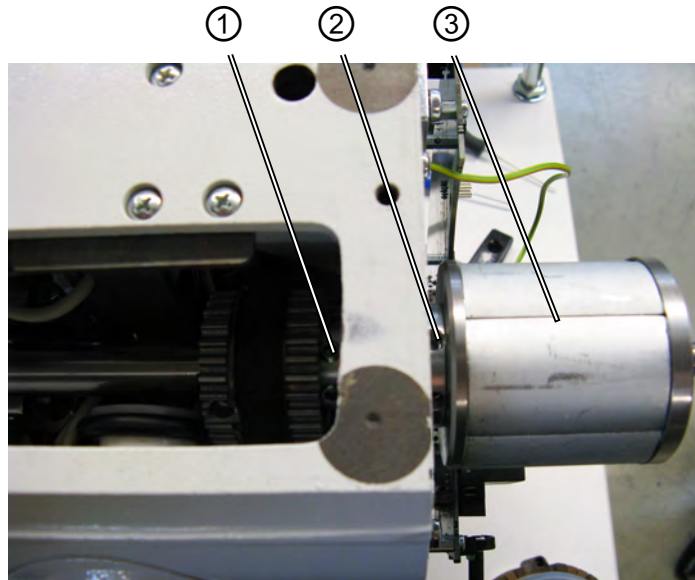

(1) - Threaded screws

(2) - Threaded screws

(3) - Rotor with deep groove ball bearing



1. Remove the arm cover.
2. Undo all four threaded screws (1, 2).
3. Remove the rotor with deep groove ball bearing (3).

4 Assembling the drive

Attaching the rotor

Figure 7: Attaching the rotor

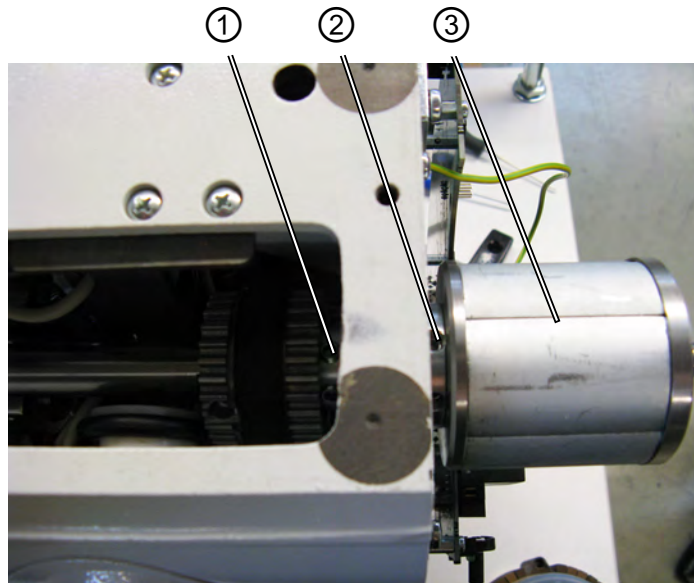

(1) - Threaded screws

(2) - Threaded screws

(3) - Rotor with deep groove ball bearing



1. Push the rotor (3) onto the shaft until the deep groove ball bearing is resting against the stop.
2. Screw all four threaded screws (1, 2) firmly in place, observing the surface of the shaft in doing so: Screw the first screw in the direction of rotation firmly in place on the surface.

**Attaching
the stator**

CAUTION



Magnetism!

Work carefully and in a controlled manner, since the stator can be pulled out of your hands.

Figure 8: Attaching the stator

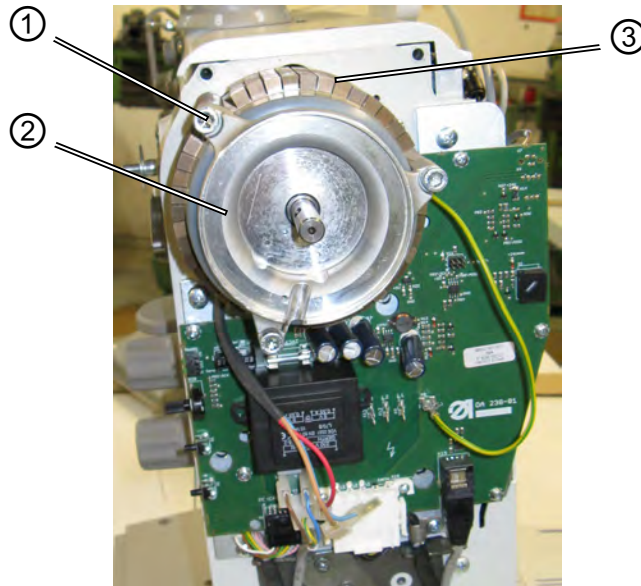

(1) - Screws

(2) - Cover plate

(3) - Stator with ring



1. Push the stator with ring (3) onto the shaft, taking care to pay attention to the ring gap for the cable.
2. Fit the cover plate (2).
3. Evenly screw all three screws (1) firmly in place such that a uniform gap exists between the cover plate (2) and shaft.

**Attaching
the encoder**

Figure 9: Attaching the encoder

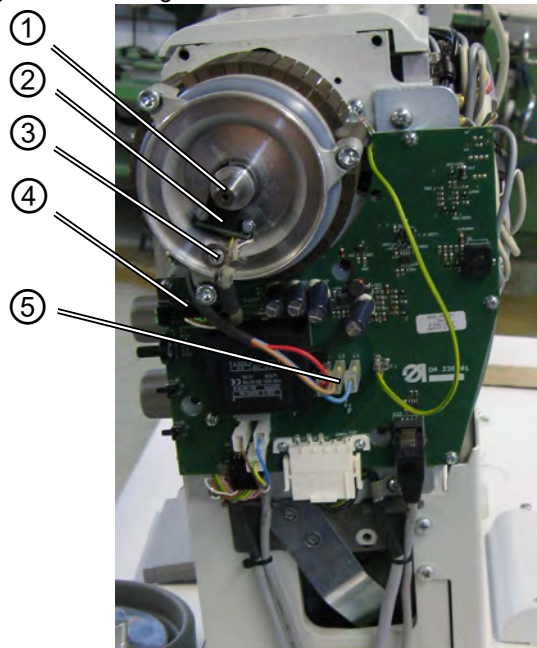

(1) - Encoder disc
(2) - Encoder
(3) - Retaining plate

(4) - Encoder plug
(5) - Plugs L1, L2, L3



1. Push the encoder (2) and encoder disc (1) onto the shaft.
2. Align the encoder disc (1) such that it runs in the middle of the encoder (2).
3. Screw the encoder disc (1) and encoder (2) firmly in place.
4. Tighten the retaining plate (3).
5. Insert plugs L1, L2, and L3 (5).
6. Insert the encoder plug (4).

Attaching the cover

Figure 10: Attaching the cover

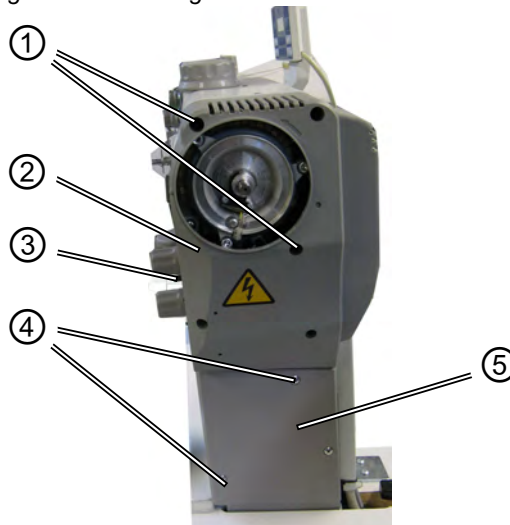

- (1) - Screws
- (2) - Upper cover
- (3) - Dial

- (4) - Screws
- (5) - Lower cover (depending on machine)



1. Carefully attach the upper cover (2) from the side, paying attention to the dial (3) in doing so.
2. Tighten all five screws (1).
3. Attach the lower cover (5) and tighten all three screws (4).

Locking the machine in place

Figure 11: Locking the machine in place

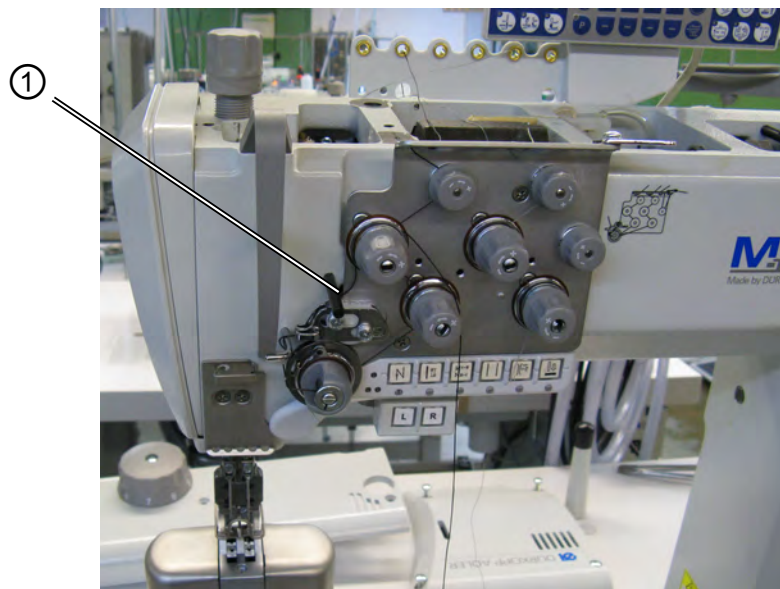

- (1) - Locking peg



1. Lock the machine in place using the Ø3 mm locking peg (1).
 ↙ The needle is in the top dead center position.

Attaching the handwheel flange

Figure 12: Attaching the handwheel flange

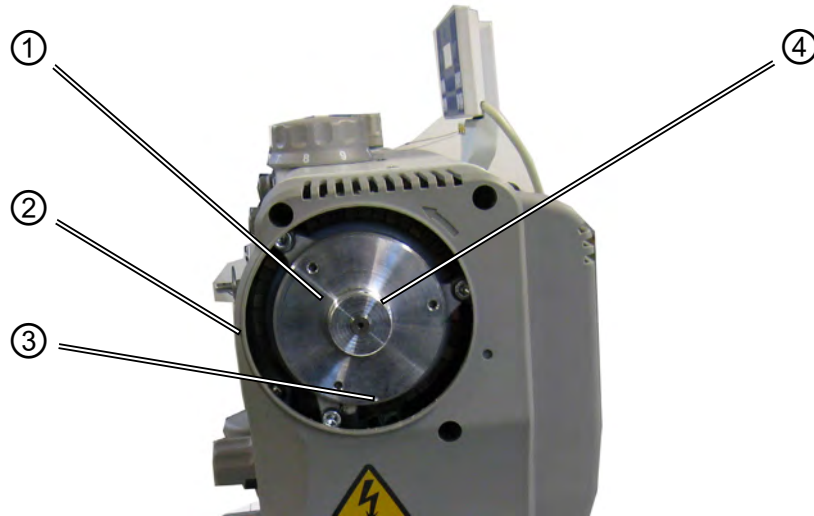

(1) - Handwheel flange
(2) - Marking for cover

(3) - Marking for handwheel flange
(4) - Setscrews



1. Attach the handwheel flange (1) such that the two markings (2, 3) are in line.
2. Tighten both setscrews (4), taking care in doing so that there is a distance of approx. 0.5 - 1 mm between the handwheel flange (1) and cover plate.

Attaching the handwheel

Figure 13: Attaching the handwheel

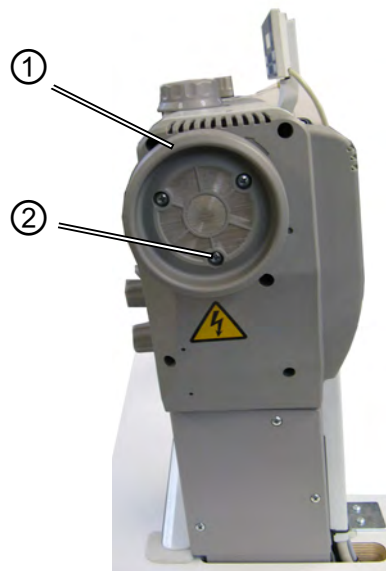

(1) - Handwheel

(2) - Screws



1. Attach the handwheel (1) and tighten all three screws (2).
2. Set the zero point via the control, see  manual for the control unit.



DÜRKOPP ADLER AG
Potsdamer Str. 190
33719 Bielefeld
Germany
Phone +49 (0) 521 925 00
E-Mail: service@duerkopp-adler.com
www.duerkopp-adler.com