



838

## Service Instructions

*All rights reserved.*

Property of Dürkopp Adler GmbH and copyrighted. Reproduction or publication of the content in any manner, even in extracts, without prior written permission of Dürkopp Adler GmbH, is prohibited.

**Copyright © Dürkopp Adler GmbH - 2021**

## Introduction

This service booklet contains the instructions for setting the sewing machine head mechanisms.

The directions for putting the machine into operation and for setting the positioning drive are contained in another publication.

The service booklet is common for all subclasses of the machine and contains also the instructions for setting optional accessories of the machine, if this is necessary owing to their complexity. Provided the machine supplied does not contain some elements, then the respective chapters may be ignored.

The succession of the setting operations is expressed here by sequencing the paragraphs of this booklet. When setting, check up, if the setting operations related to this setting have already been performed.

## General safety instructions

**The non-observance of the following safety instructions can cause bodily injuries or damages to the machine.**

1. The machine must only be commissioned in full knowledge of the instruction book and operated by persons with appropriate training.
2. Before putting into service also read the safety rules and instructions of the motor supplier.
3. The machine must be used only for the purpose intended. Use of the machine without the safety devices is not permitted. Observe all the relevant safety regulations.
4. When gauge parts are exchanged (e.g. needle, presser foot, needle plate, feed dog and bobbin) when threading, when the workplace is left, and during service work, the machine must be disconnected from the mains by switching off the master switch or disconnecting the mains plug.
5. Daily servicing work must be carried out only by appropriately trained persons.
6. Repairs, conversion and special maintenance work must only be carried out by technicians or persons with appropriate training.
7. For service or repair work on pneumatic systems, disconnect the machine from the compressed air supply system (max. 7-10 bar). Before disconnecting, reduce the pressure of the maintenance unit. Exceptions to this are only adjustments and functions checks made by appropriately trained technicians.
8. Work on the electrical equipment must be carried out only by electricians or appropriately trained persons.
9. Work on parts and systems under electric current is not permitted, except as specified in regulations DIN VDE 0105.
10. Conversion or changes to the machine must be authorized by us and made only in adherence to all safety regulations.
11. For repairs, only replacement parts approved by us must be used.
12. Commissioning of the sewing head is prohibited until such time as the entire sewing unit is found to comply with EC directives.
13. The line cord should be equipped with a country-specific mains plug. This work must be carried out by appropriately trained technicians (see paragraph 8).



It is absolutely necessary to respect the safety instructions marked by these signs.

**Danger of bodily injuries !**

Please note also the general safety instructions.



## Service Instructions for the Class 838

(Edition 11.2021)

<b>1</b>	<b>General</b>	
1.1	Setting gauges . . . . .	5
1.2	Adjusting the handwheel . . . . .	6
1.2.1	Sewing machine with minimotor . . . . .	6
1.2.2	Sewing machine with direct drive . . . . .	7
<b>2.</b>	<b>Bottom feed</b>	
2.1	Basic setting for stitch adjustment and stitch length limit . . . . .	8
2.2	Stitch uniformity for forwards and reverse stitching . . . . .	9
2.3	Adjusting the levers on the rear feed shaft . . . . .	10
2.4	Position of the eccentric tappet for the feed movement . . . . .	11
2.5	Position of the eccentric tappet and the feed dog stroke . . . . .	12
2.6	Switching over the feed clutch . . . . .	13
2.7	Position of the eccentric tappet for the switch over of the feed clutch . . . . .	14
2.8	Checking the switch over of the feed clutch . . . . .	15
2.9	Feed dog. . . . .	16
2.10	Balance weight . . . . .	17
<b>3</b>	<b>Top feed</b>	
3.1	Position of the needle holder for single needle sewing machines . . . . .	19
3.2	Needle bar holder . . . . .	20
3.3	Top roller. . . . .	22
3.4	Lifting the top roller . . . . .	23
3.5	Fabric holder for double needle sewing machines . . . . .	24
<b>4</b>	<b>Setting the needle bar and the hook</b>	
4.1	Hook height . . . . .	25
4.2	Needle bar height, play of needle to hook tip, loop stroke . . . . .	26
4.3	Hook tip guard and loop former . . . . .	27
4.4	Bobbin housing release . . . . .	28
4.2	Hook lubrication . . . . .	29
<b>5</b>	<b>Thread setting</b>	
5.1	Thread regulator, check spring, bolt for the thread lever mechanism. . . . .	30
5.2	Bobbin winder. . . . .	31
<b>6</b>	<b>Thread cutter</b>	
6.1	Thread cutter height, position of the counter knife . . . . .	32
6.2	Starting position for the thread pulling knife. . . . .	33
6.3	Control cam . . . . .	34
6.4	Bobbin thread clamp. . . . .	35

<b>7.</b>	<b>Electronic control and sewing machine drive - positioning motor . . . . .</b>	<b>36</b>
7.1	Terminals to PCB connections - electromagnetic variant . . . . .	37
7.2	Terminals to PCB connections - pneumatic variant . . . . .	38

# 1 General

These service instructions describe the adjustments that can be made to the class **838** special sewing machine.



## **CAUTION!**

The operations described in these service instructions may only be carried out by qualified staff or other appropriately trained persons!



## **Caution: Risk of injury!**

Turn the main switch off for repair, conversion and maintenance work and separate the machine from the pneumatic supply line.

Any adjustment work and functional testing with the machine running should be conducted only under observance of all safety measures and with the greatest possible caution.

EN

These service instructions describe the adjustment of the sewing machine in a logical order. Please observe that various setting positions are dependent on each other. Thus it is essential that the settings be conducted while keeping to the order described.

For all adjustments of parts involved in the stitch formation, a new undamaged needle must be inserted.

This text does not specifically mention any machine covers or panels which must be removed or re-mounted in order to conduct inspections or adjustments.

## **Note**

Some shafts on the special **838** machine are provided with flat eccentric surfaces. This significantly simplifies machine adjustments.

For all adjustments on flat surfaces, the first screw screwed in the direction of the eccentric surface.

## 1.1 Setting gauges

The retention pin required for adjusting the machine is included with all units. It is located with the machine accessories and can be attached so that it is easily accessible below the oil tray.

## 1.2 Adjusting the handwheel

### Rule:

The handwheel (4) is labelled with degree numbers.

Certain adjustments are made with these marked handwheel positions.

- Turn the handwheel until the degree value specified in the instructions is aligned with the pointer (3).
- Proceed with the adjustment described.

When the needle bar is at top dead centre, the pointer (3) should be aligned with “0” degrees.

### 1.2.1 Sewing machines with minimotor

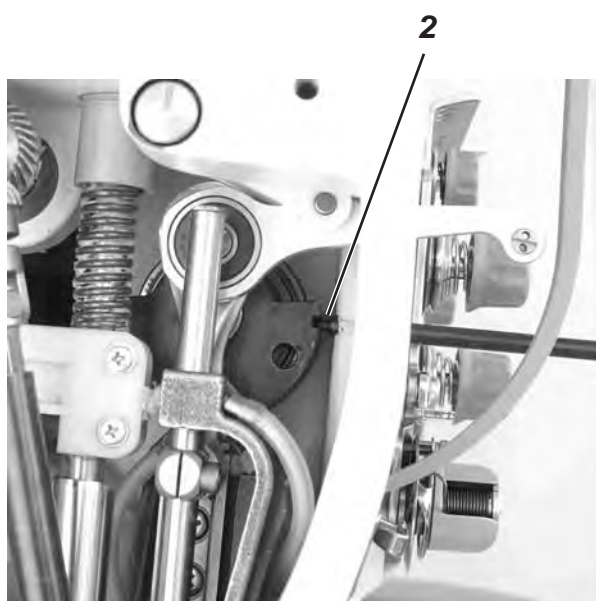
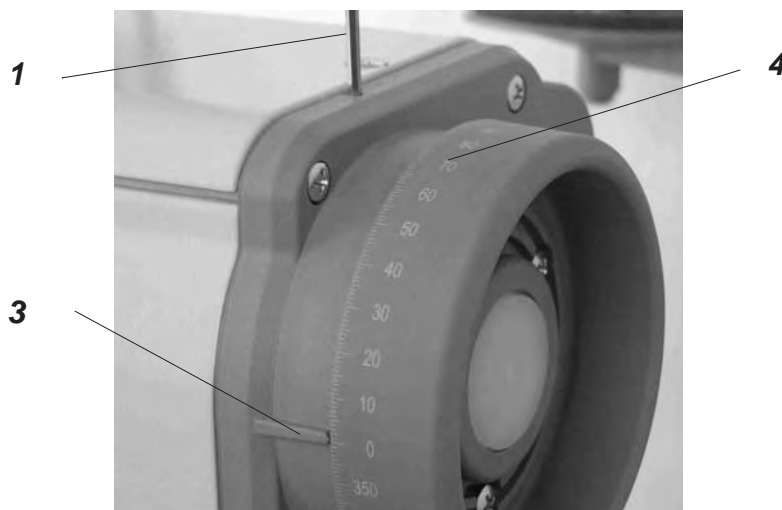

- Loosen the handwheel screws with a 3 mm Allen key (1).
- Position the needle bar in the upper dead centre position. Use the retention pin (3 mm diameter) to peg the position (2).
- Turn the handwheel so that the pointer (3) points to 0 degrees on the rotary scale.
- Tighten the first screw with the Allen key (1). Turn the handwheel to 50° and tighten the second screw with the Allen key (1).



## 1.2.2 Sewing machine with direct drive

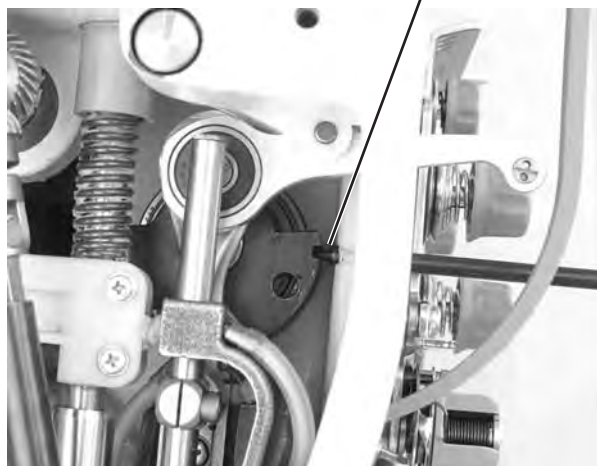
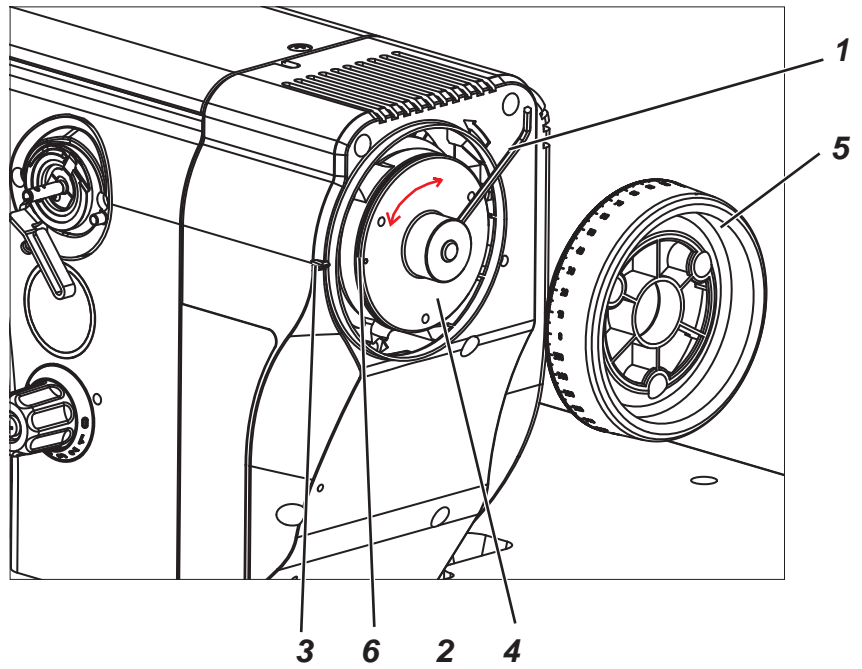

- Unscrew three fixing screws on the hand wheel (5) and remove it.
- Put the needle in the upper dead point and insert the setting pin (2), which is a part of the sewing machine accessories and which is fixed on the oil tray bottom side, into the crank head.
- Loosen two setting screws of the hand wheel flange (4) with the Allen key 3 mm (1).
- Turn the hand wheel flange with the hollow (6) against the sign (3).
- Tighten both setting screws with the key (1) and fix the hand wheel on again.

## 2 Bottom feed

### 2.1 Basic setting for stitch adjustment and stitch length limit

#### Rule:

1. When setting the stitch length at "0", the stitch regulator gear should have as little play (clearance) as possible when you press down on the bartacking lever.
2. The maximum stitch length is limited to **8 mm**.

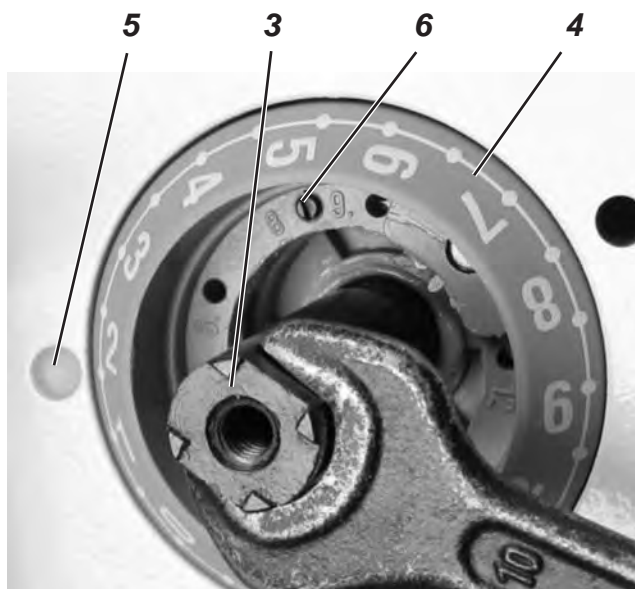

- Loosen screw (1) and take off the settings dial (2).
- Turn the screw (3) as far as needed to the right using a 10 mm open-ended wrench. Verify that the stitch regulator gear is without motion by pressing down on the bartacking lever. This fulfills rule 1.
- Set the scaling ring (4) with stitch length "0" to align with the circular mark (5).
- Limit the stitch length according to rule 2. For this, screw the retention pin (6) into the proper hole. The holes are marked with numbers which indicate the maximum stitch length.
- Put the settings dial (2) back on and tighten the screw (1).



#### Caution: Risk of injury!

Turn the main switch off.

Only carry out this basic stitch adjustment when the machine is turned off.

## 2.2 Stitch uniformity for forwards and reverse stitching

### Rule:

1. When making a rough-scale adjustment to the stitch regulator gear, the machine should not feed when the stitch length is set to "0".
2. When making a fine-scale adjustment to the stitch regulator gear, the forwards and reverse stitch lengths should only deviate in value by a half stitch.

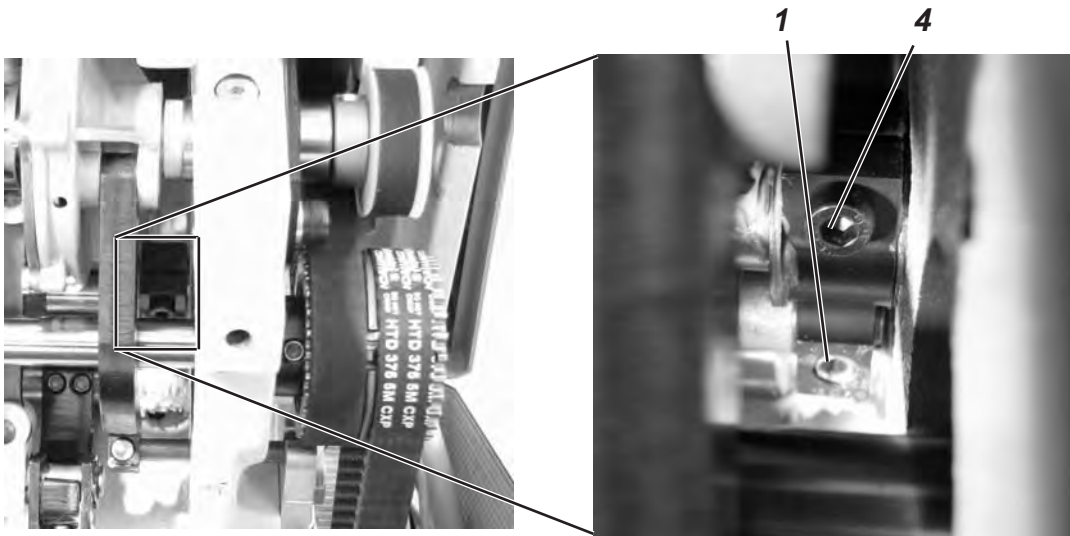
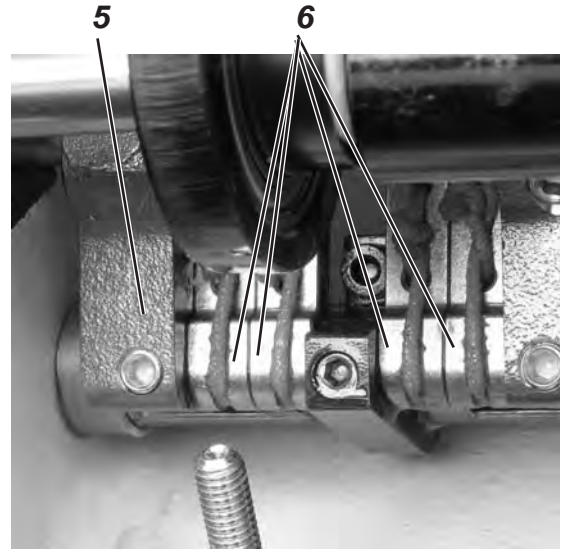
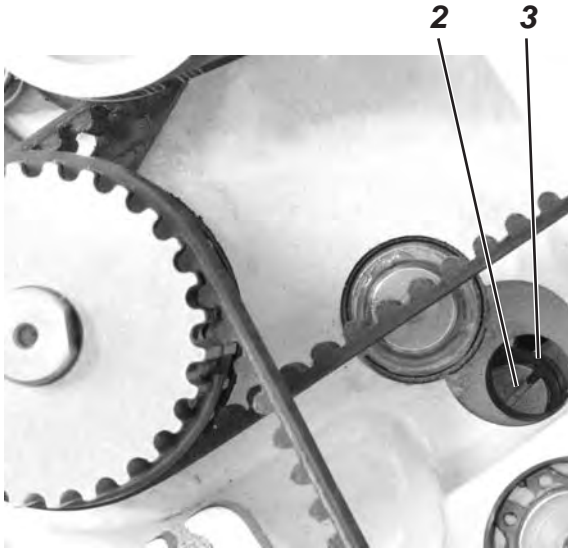

- Set the stitch length to "0".
- Loosen screw (1) and turn the grooved (3) eccentric tappet (2) according to the illustration. Fasten with screw (1).
- Loosen screw (4) on the clamping lever. Turn the settings frame (5) so that the shackles (6) are parallel. Tighten screw (4). This then fulfils rule 1.
- The next step is to match up the forwards and reverse stitch lengths. Sew ten stitches forwards. Press the bartacking lever and then sew ten stitches backwards. Rotate the eccentric tappet (2) so that rule 2 is fulfilled.
- Clockwise = increase forward stitch, decrease reverse stitch.
- Counter-clockwise = decrease forward stitch, increase reverse stitch.

EN

## 2.3 Adjusting the levers on the rear feed shaft

### Rule:

When setting the stitch length "0", the feed clutch should be in the middle range of the work limit settings.

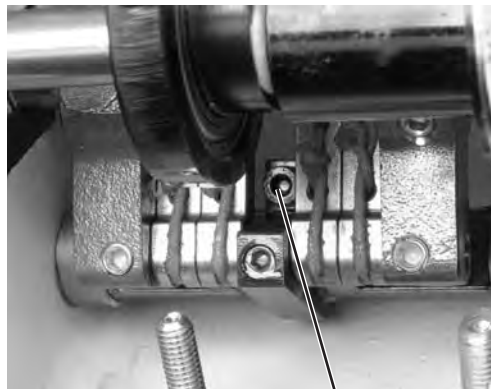
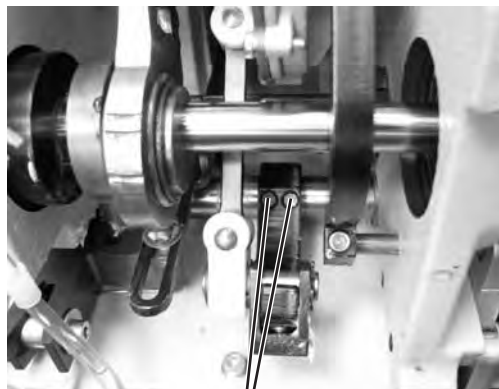

2

3

4

1



- Set the stitch length to "0".
- Loosen screw (1).
- Set the lower feed dog in the middle between the dead centre points of its motion in the throat plate.
- Tighten screw (1).
- Loosen screws (2).
- Screw out the screw on the feed clutch (4). Push the needle (3) into this opening. Turn the clutch (4) with your hand until the needle (3) is **5 mm** into the hole. The rule is then fulfilled.
- Tighten screw (1).



### Caution: Risk of Injury!

Turn the main switch off.  
Only carry out this lever adjustment when the machine is turned off.



### ATTENTION: Danger of breakage!

With large stitch lengths, it is possible that parts within the clutch will collide if the middle working range of the clutch is not maintained.

## 2.4 Position of the eccentric tappet for the feed movement

### Rule:

When the handwheel pointer indicates “355” degrees, the feed lever (1) should not move when the bartacking lever is pressed down.

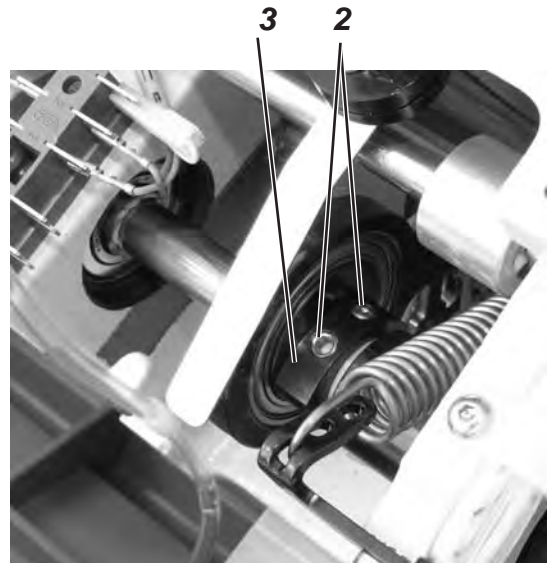
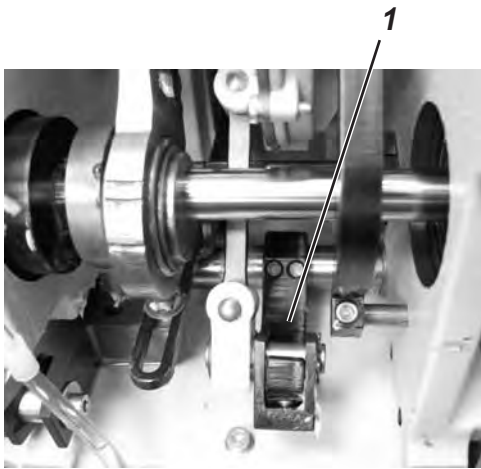

- Turn the handwheel so that the pointer indicates “355”.
- Loosen screws (2). To make the rough-scale adjustment, turn the eccentric tappet (3) so that it is approximately in the position shown in the illustration. Now make the fine-scale adjustment to the eccentric tappet. Continue until you have found the position where the feed lever (1) no longer moves when the bartacking lever is pressed down.
- Tighten screws at eccentric tappet (3).



### Caution: Risk of injury!

Turn the main switch off.

Only carry out this eccentric adjustment when the machine is turned off.



### ATTENTION: Danger of breakage!

Imprecise settings can shorten the lifespan of the machine.

## 2.5 Position of the eccentric tappet and the feed dog stroke

### Rule:

When the handwheel pointer indicates “239” on the scale, a settings pin inserted into the eccentric tappet should be flush with the ridge on the crankshaft (4).

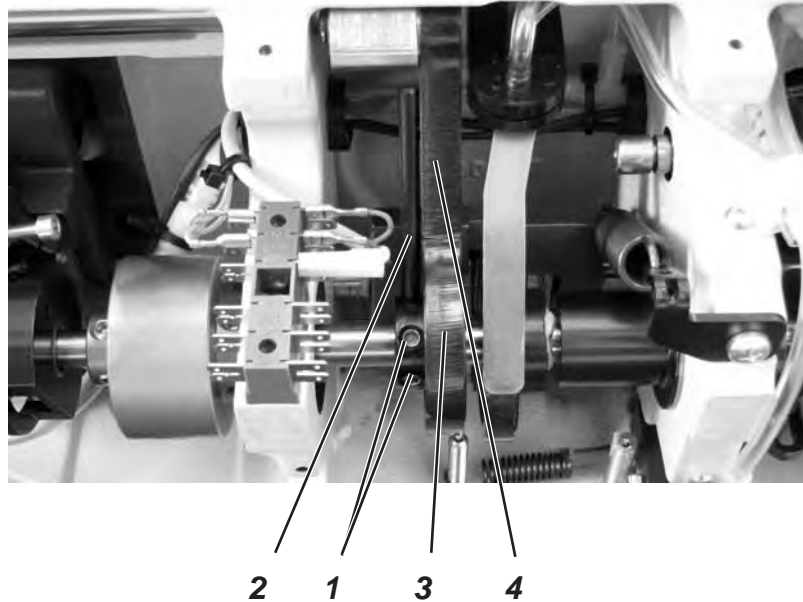

- Turn the handwheel so that the pointer indicates “239”. Loosen screws (1).
- Insert a settings pin (2) into the eccentric tappet (3). Position it so that it is flush with the crankshaft ridge.
- Tighten screws (1).



### **Caution: Risk of injury!**

Turn the main switch off.

Only carry out this eccentric adjustment when the machine is turned off.

## 2.6 Switching over the feed clutch

### Rule:

The clutch should be switched over when it is motionless (i.e., when it is in the dead centre point of its pendulum motion).



- Loosen the screws (1) on the eccentric tappet (2).
- Turn the eccentric tappet (2) so that the dash is aligned with the other dash (3).
- Loosen the three screws (4). Loosen the adjusting nut (5).
- Tighten the adjusting nut (5) until you feel it strike (the tightening increases in jumps). Push the clutch (6) to the right until the end stop is reached. Tighten the screws (4).
- Verify the adjustment. Turn the eccentric tappet with your hand in the other direction. The resistance during the rotation of the eccentric tappet should increase significantly when the two dashes are lined up.



### **Caution: Risk of injury!**

Turn the main switch off.

Only carry out this adjustment when the machine is turned off.



### **ATTENTION: Danger of breakage!**

Imprecise settings can shorten the lifespan of the machine.

## 2.7 Position of the eccentric tappet for the switch over of the feed clutch

### Rule:

When the handwheel pointer indicates “305” on the scale, the dash (1) on the eccentric tappet should be lined up with the lower dash (2) on the V-shaped push rod.

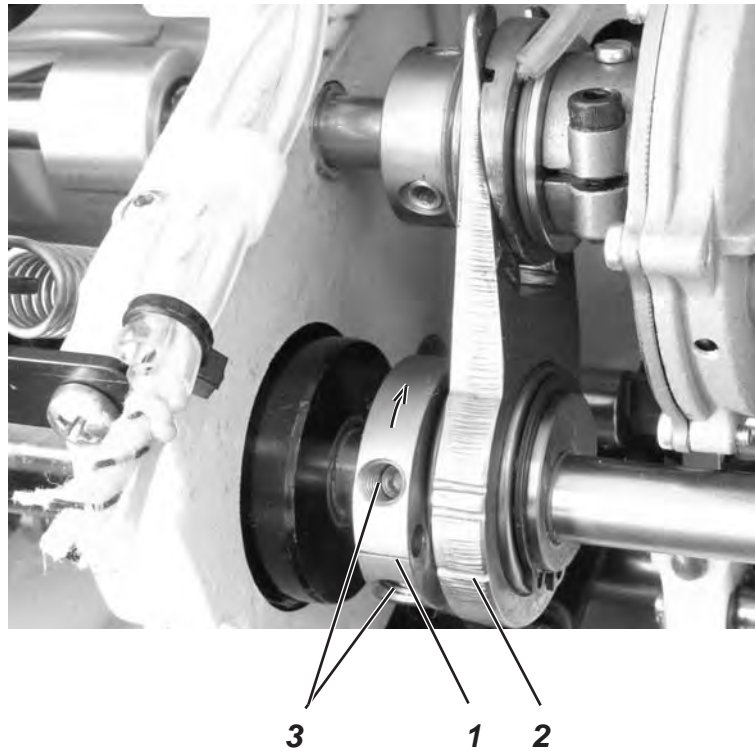

- Loosen screws (3).
- Turn the handwheel to position “305”.
- Turn the eccentric tappet in the direction of arrow so that dash (1) is lined up with dash (2).
- Turn back the eccentric tappet about  $2^\circ$  and move axially on the shaft until the middle is between the limit settings.
- Align the two dashes (1) and (2) again. Tighten the screws (3).



### Caution: Risk of injury!

Turn the main switch off.

Only carry out this adjustment when the machine is turned off.



## 2.8 Checking the switch over of the feed clutch

### Rule:

The feed clutch should be switched over when it is motionless (i.e., when it is in the dead centre point of its pendulum motion). This can be detected from the rotational direction of the belt pulley (1) in front of and behind the dead centre point.

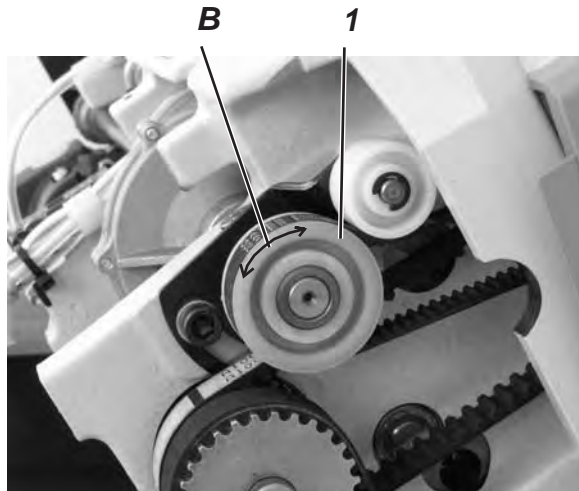

	1	2	3	4
A	270°	276°	88°	93°
B	0	→	←	0

- Set the maximum stitch length.
- Turn the handwheel (A) so that it is positioned at “270” degrees (refer to Table / A). Push the bartacking lever down. Check if the rotational direction (B) of the belt pulley (1) corresponds to the direction specified in the table. Do the same for “276” degrees.
- If the rotational directions do not correspond to those specified in the table, correct the necessary settings. If the clutch switches over too soon (on a smaller angle), tentatively loosen the adjusting nut (5) (see chapter 2.6) and repeat the check. Continue loosening until you locate the correct position for the nut. If the clutch switches over too late, tighten the controlling nut (5).



### Caution: Risk of Injury!

Turn the main switch off.

Only carry out this adjustment when the machine is turned off.



### CAUTION!

Imprecise settings can shorten the lifespan of the machine.

## 2.9 Feed dog

### Rules:

1. The height **(A)** that the feed dog (1) is above the throat plate must be appropriate for the thickness and toughness of the material.
2. In its highest position **(A)**, the feed dog should be 1 mm over the throat plate insert.

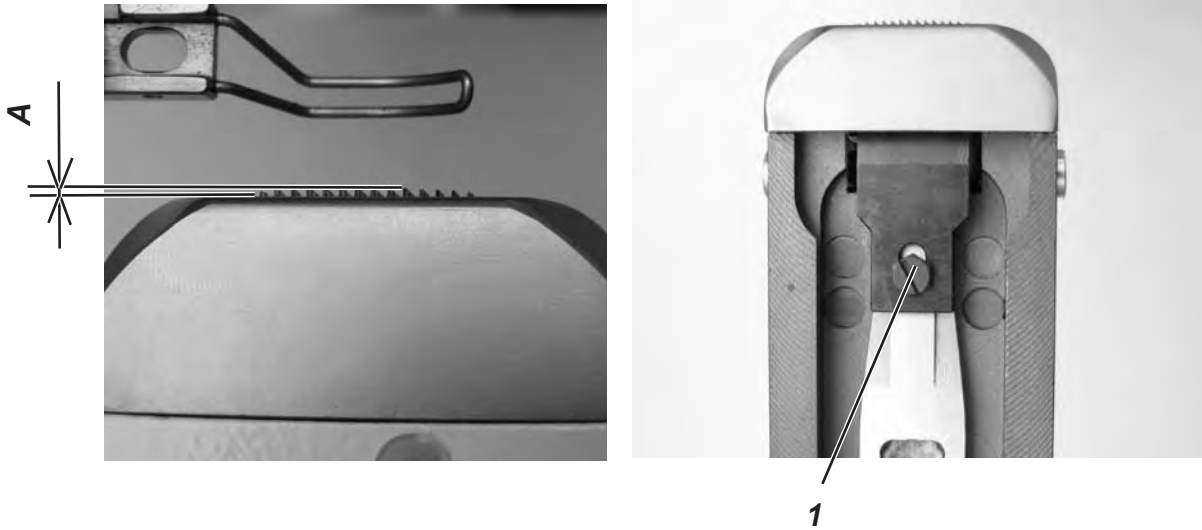

- Loosen screw 1.
- According to the above rule, lower or raise the feed dog. Then re-tighten screw (1).

## 2.10 Balance weight

### Rule:

The balance weight (1) has to be positioned in a way that, with the handwheel in position “210°”, an Allen key (3) stuck in stands parallel to the bed plate (2).



1



3

2

- Loosen the screws on the balance weight (1).
- Turn the balance weight (1) according to the rule.
- Tighten the screws on the balance weight (1).



### Caution: Danger of injury !

Turn the main switch off !

Check and set the balance weight only with the sewing machine switched off.

Notes:

### 3 Top feed

#### 3.1 Positioning the needle holder for single-needle sewing machines

**Rule:**

The needle holder positioning is carried out according to the following table and depends on the thickness of the needle.

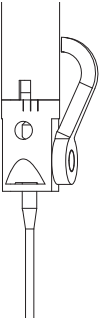
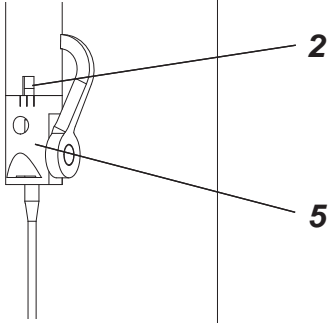
Angularity of the needle holder		
Needle width/ Nm	120 - 160	180 - 200

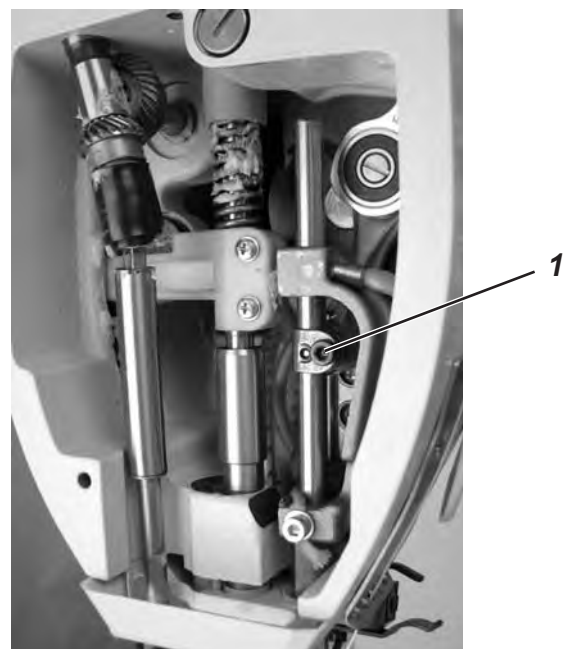
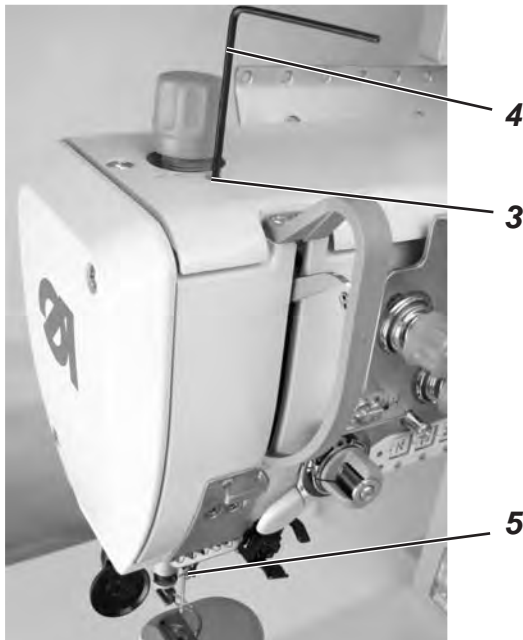

- Loosen screw (1). Turn the needle bar with the right grooved edge (2) on the needle-bar axis (in the sewing direction). Tighten screw (1).
- Move the needle bar into the top dead centre point. Use the 2.5 mm hexagon socket wrench (4) to loosen the needle-holder screw in the hole (3).
- Turn the needle holder (5) according to the rule above. Tighten the screw (1).

## 3.2 Needle bar holder

### Rules:

1. The needle bar should be adjusted so that it is flush with the presser foot bar.
2. The post bed feed should be:
  - 2.1 for the single-needle machine, it should be set so that the axis of the needle is moved **(A) = 0.1mm** to the left to the middle of the stitch hole.
  - 2.2 for the double-needle machine, it should be set so the needle stands symmetric to the middle of the stitch hole.
3. The needle position is to be adjusted so that the needle is at the rear edge of the stitch hole.

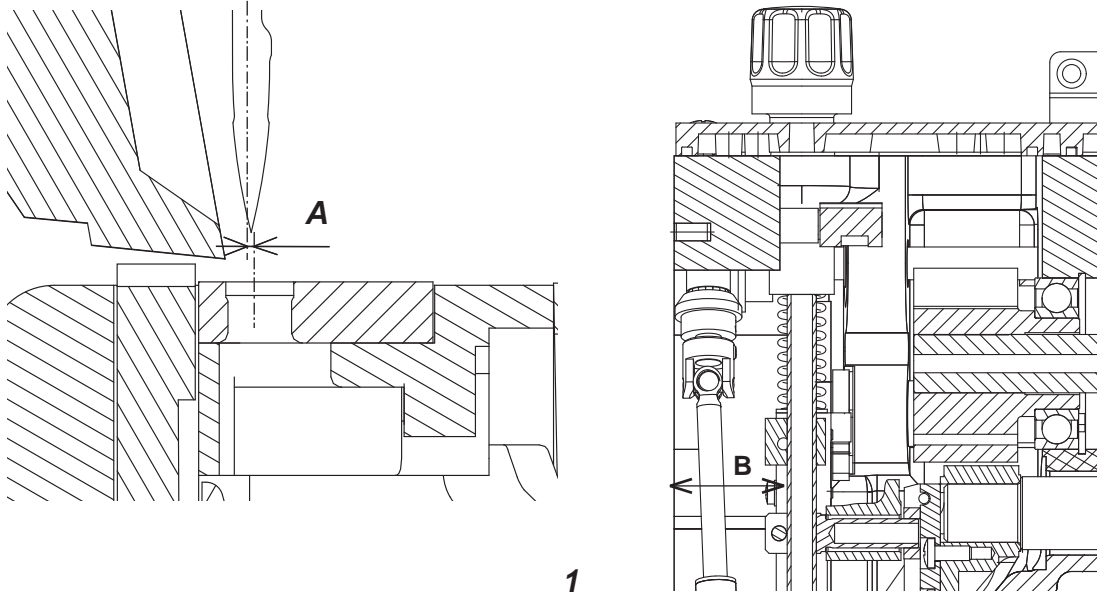

- Loosen screws (1) and adjust the needle bar to the dimension **(B) = 31mm** as show in the illustration. Rule 1 has been fulfilled.

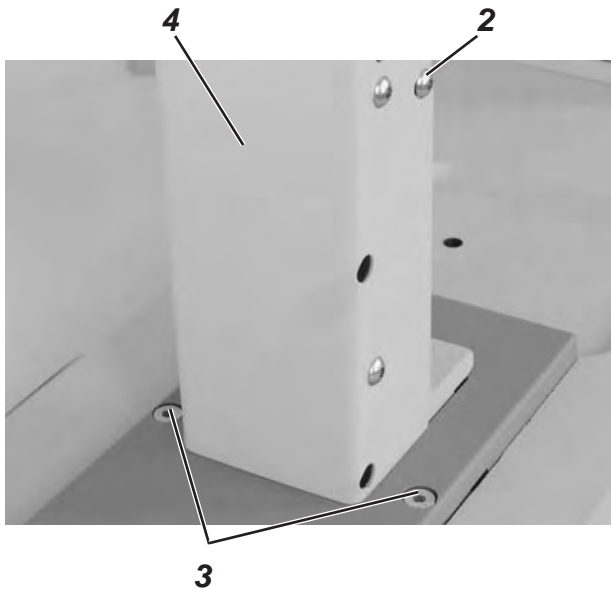

**Fig. 1**

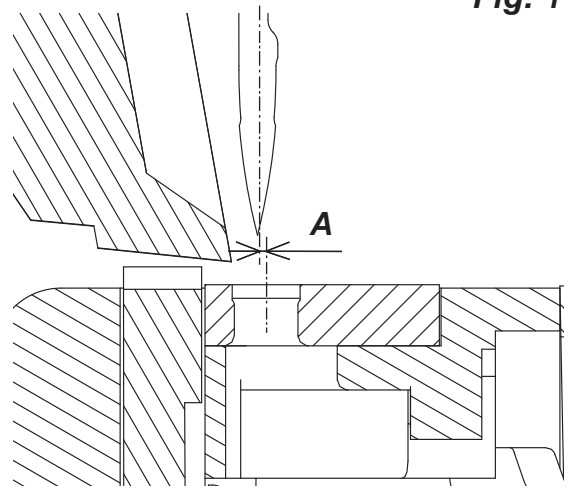

**Fig. 2**

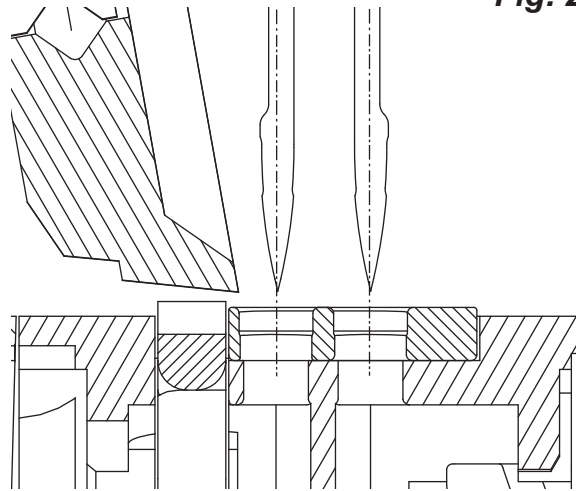

- Loosen screw (2) and the two screws (3). Move the post bed feed (4) so that either rule 2.1 is met (**A = 0.1 mm**) according to **Figure 1**, or rule 2.2 according to **Figure 2**.

### 3.3 Top roller

#### Rules:

1. The seating area on the top roller holder should be aligned at a right angle to the machine's longitudinal axis (centre-line).  
A clearance of **(A) = 0 mm** should exist between the top roller and the throat plate.
2. The position of the top roller in the sewing direction should be adjusted as follows:
  - for single-needle machines: **(B) = 1.3 to 2.3 mm**
  - for double-needle machine: **(B) = 0 to 2.3 mm**
3. The lateral position of the top roller should be set so that the lower edge of the top roller is aligned with the left edge of the stitch hole (8).

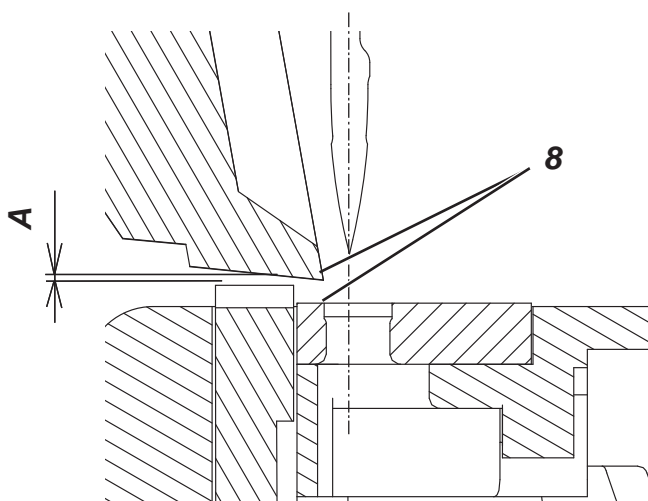
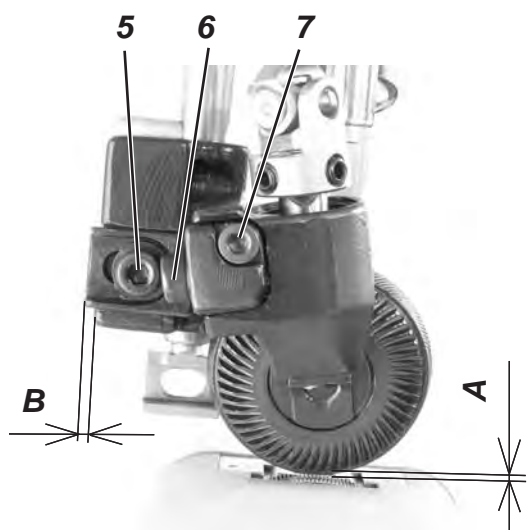
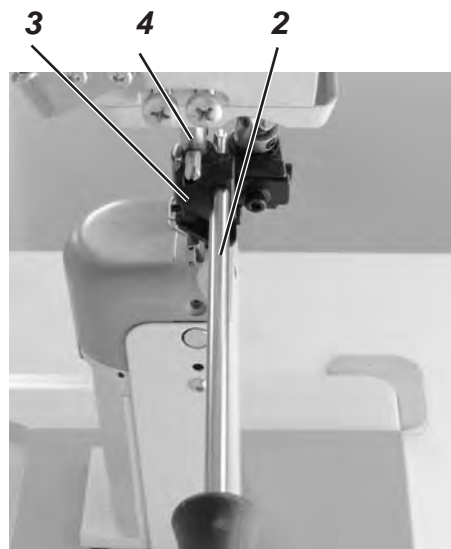
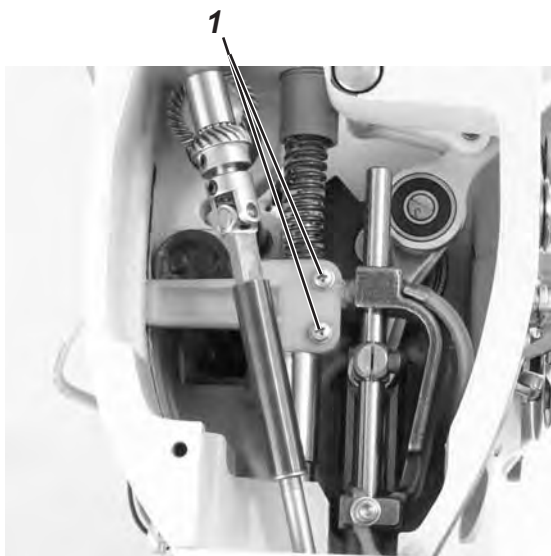

- Loosen screws (1). Push the presser foot bar perpendicularly, according to rule 1. Insert the cross-head screwdriver (2) (included with the accessories) into the hole on the top roller holder (3). Turn the presser foot bar (4) with top roller holder (3) until the screwdriver is at a right angle to the machine's longitudinal axis. Tighten the screws (1).
- Loosen screw (5). Move the top roller according to rule 2. Tighten screw (5).
- Loosen screw (6). Move the top roller by turning the screw (7), according to rule 3. Tighten screw (6).



### 3.4 Lifting the top roller

#### Rules:

1. The top roller should have a **5.4 to 5.6 mm** lift from the hand lever.
2. The top roller should have an **11.5 to 12.5 mm** (automatic) lift with the pneumatic cylinder.

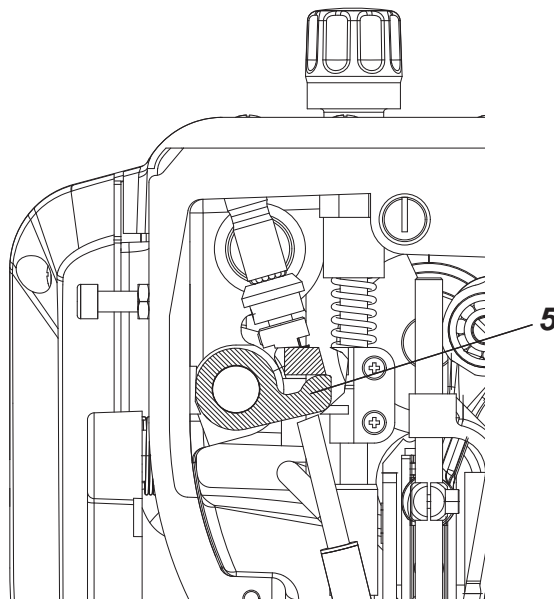
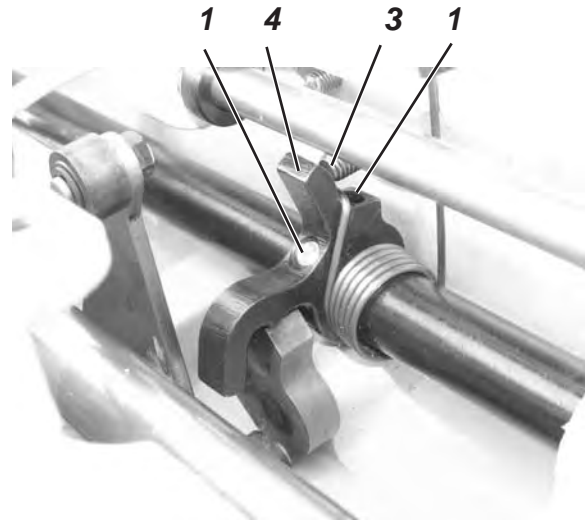
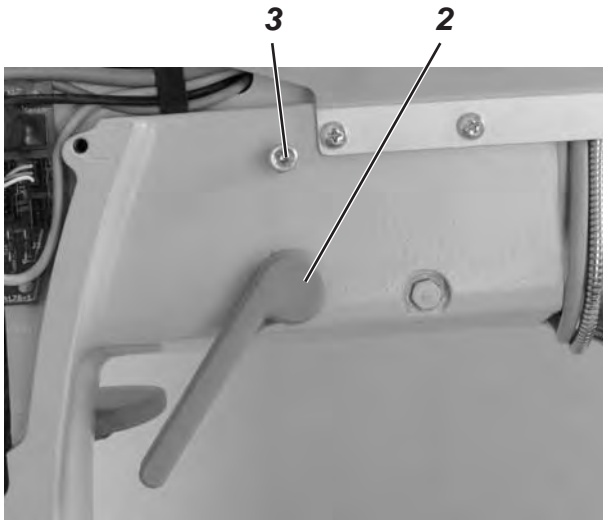

- Loosen screws (1). Move the hand lever (2) into the position shown. At the same time, screw in the screw (3) until it hits the lever (4).  
The lever (2) remains in the position shown.
- Position the spacer 5.6 mm below the top roller. Move the hand lever (5) to the end stop as shown in the illustration. Tighten the screws (1). Rule 1 has been fulfilled.
- Using screw (3), set the ventilation (cylinder lift) for the pneumatic cylinder according to rule 2. The set value is also valid for the knee lever.

EN

### 3.5 Fabric holder for double needle sewing machines

#### Rules:

1. The fabric holder should touch the sewing material without exerting any pressure on it.
2. The fabric holder should be positioned in sewing direction and laterally on the edges of the stitch holes.

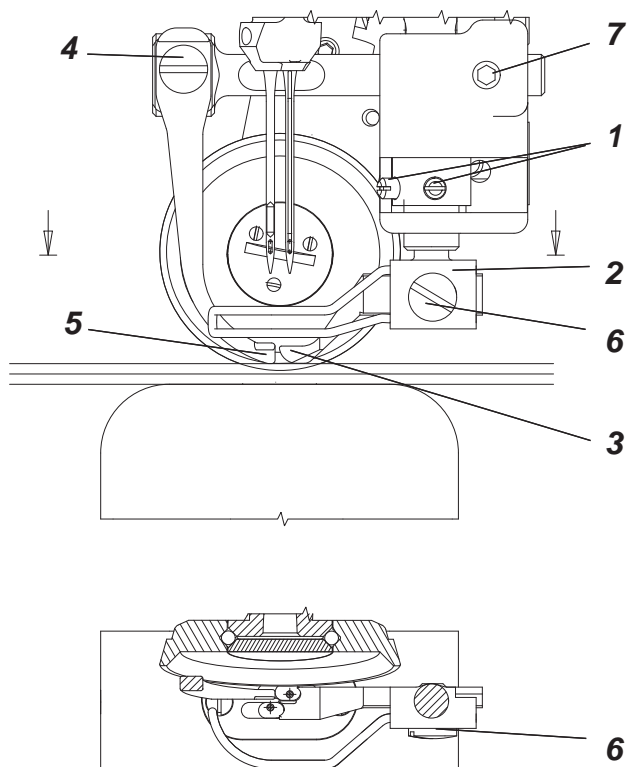

- Insert two pieces of material of about 1.5 mm thickness underneath the roller foot and set a medium fabric pressure.
- Loosen screw (1) and displace the holder (2) with the rear fabric holder (3) vertically until it comes to rest without any pressure on the leather. Tighten screw (1), but not too hard. Loosen screw (4) and effectuate the same setting for the front fabric holder (5). Remove the leather, rule 1 is now accomplished.
- Set the fabric holder according to rule 2: Set the rear fabric holder (3) to the sewing direction by using screw (6) and laterally by turning the holder (2). Set the front fabric holder to the sewing direction and laterally by using screw (7).
- Tighten all screws.



#### Caution: Danger of injury !

Turn the main switch off.

Proceed with the setting only with the sewing machine switched off.

## 4 Setting the needle bar and the hook

### 4.1 Hook height

#### Standard checking

The distance **A** should be 1.7 up to 1.8 mm.

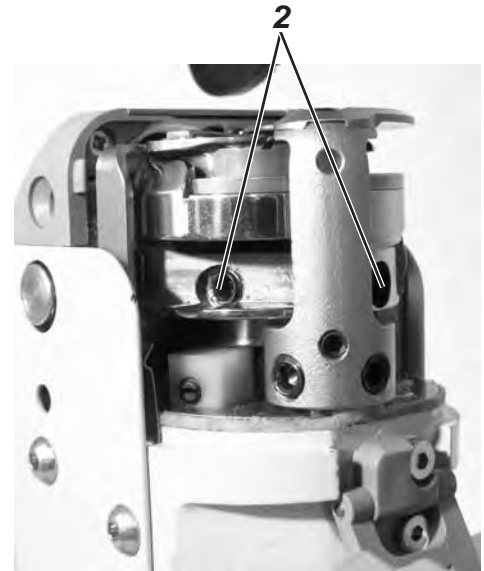
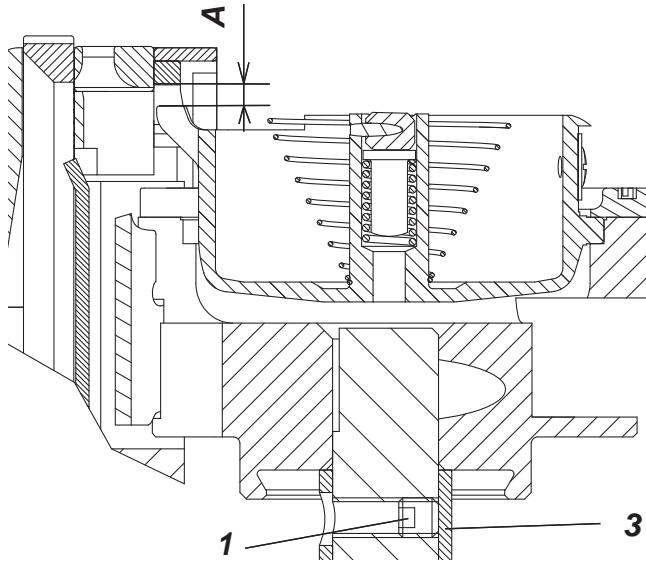

EN

- Loosen screw (1).
- Loosen screws (2), shift the hook at the distance **(A)** and tighten the screws (2).
- Push the ring (3) until it stops at the hook bottom and tighten screw (1). When replacing the hook, it is not necessary to readjust its setting in height again.



#### Caution: Danger of injury !

Turn the main switch off.

Proceed with the hook setting only with the sewing machine switched off.

## 4.2 Needle bar height, play of needle to hook tip, loop stroke

### Rule:

When the handwheel pointer indicates “205” degrees (2.5 mm loop stroke), the hook tip should stand at the needle axis at the stitch length 0. Length (A) = 1.5 mm, clearance gap (B) = 0.02 to 0.1 mm.

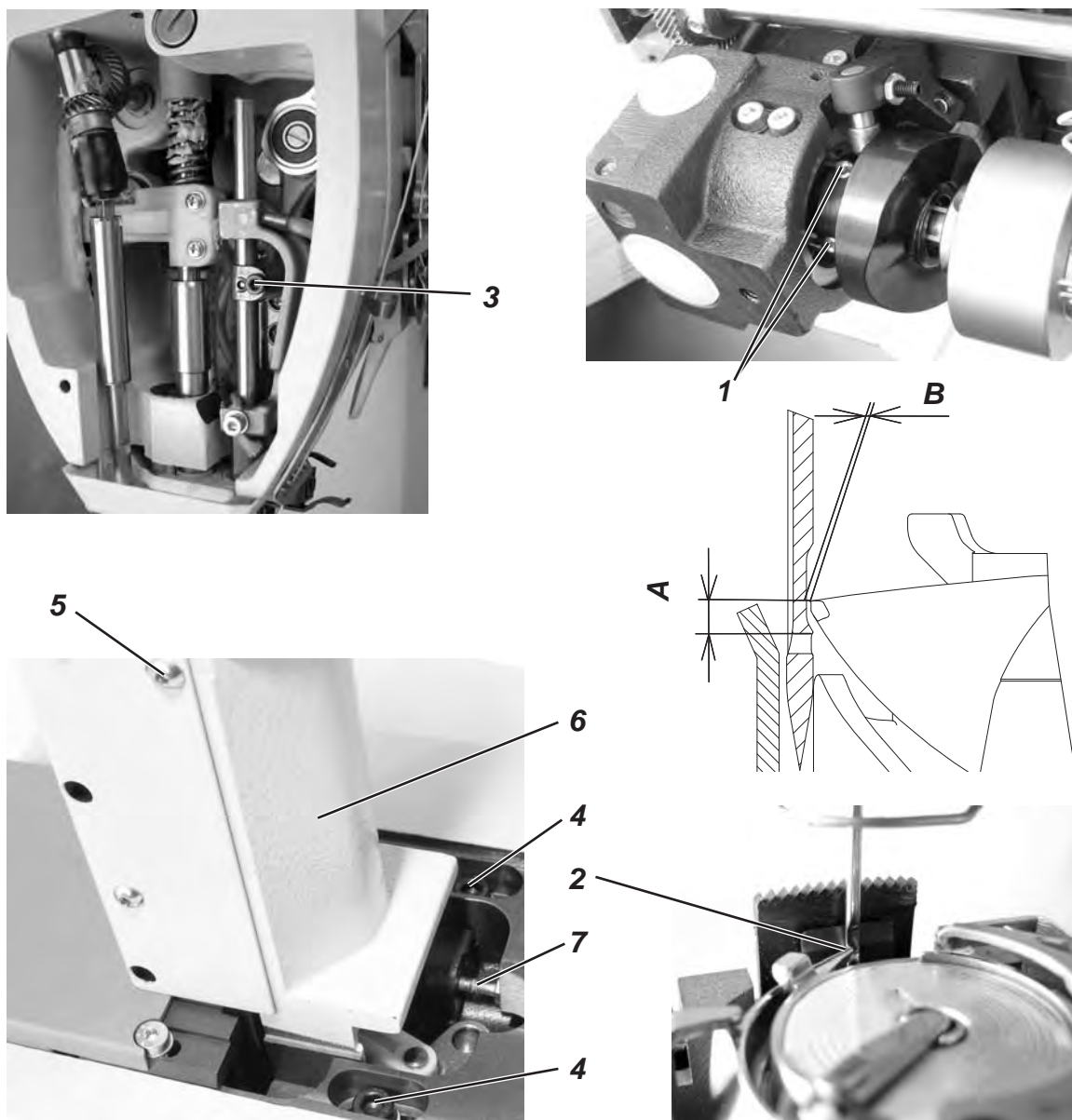

- Turn the handwheel so that the pointer indicates “205”.
- Loosen screws (1). Turn the hook tip (2) on the needle axis.
- Loosen screw (3). Position the needle bar with the needle to the dimension (A). Tighten screw (3).
- Loosen two screws (4) and screw (5). Move the hook column (6) from the needle.
- Tighten screws (4) gently. With the help of screw (7), move the hook column (6) to the clearance distance (B). Tighten screws (4) and (5).
- Verify that the hook tip (2) is in the area of the needle axis. Tighten screws (1).

### 4.3 Hook tip guard and loop former

**Rule:**

1. The loop former (1) with the single needle machines should be set to have a distance to the needle thickness of **(A) = 0.1 to 0.2 mm**.
2. The guard plate of the hook (3) should prevent a contact between the needle and the hook tip (4).

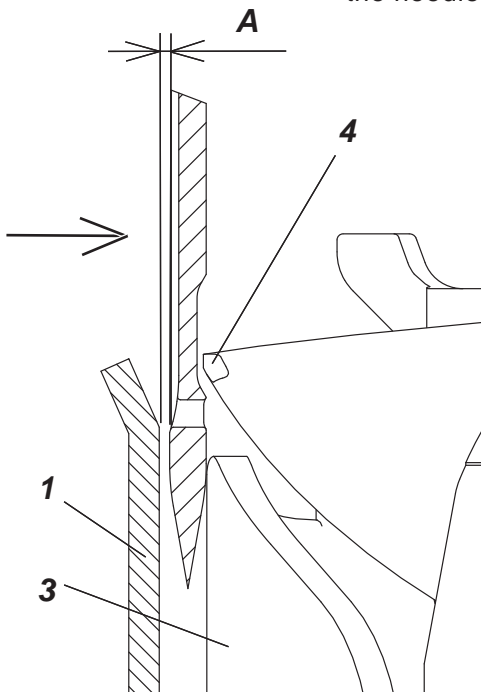

EN

- Set the maximum stitch length according to the sewing equipment.
- Dismount the throat plate.
- Bend the loop former (1) to have the distance **(A)** according to rule 1.
- Turning the screw (2), set the guard (3) so that it prevents the needle being caught with the hook point (4). Check in pushing the needle at the spot of the arrow with simultaneous turning the hook.
- The setting is not incorrect if the guard plate (3) slightly deflects the needle.



**Caution: Danger of injury !**

Turn the main switch off.

Proceed with the setting of the hook guard and loop former only with the sewing machine switched off.

## 4.4 Bobbin housing release

### Rules:

1. When the retention pin (1) is inserted into the lifting cam, the handwheel indicator should point to:
  - From "305" to "315" for the right hook column
  - or
  - from "42" to "52" for the left hook column.
2. The clearance distance (A) at max. lift should be **0.8 mm**.

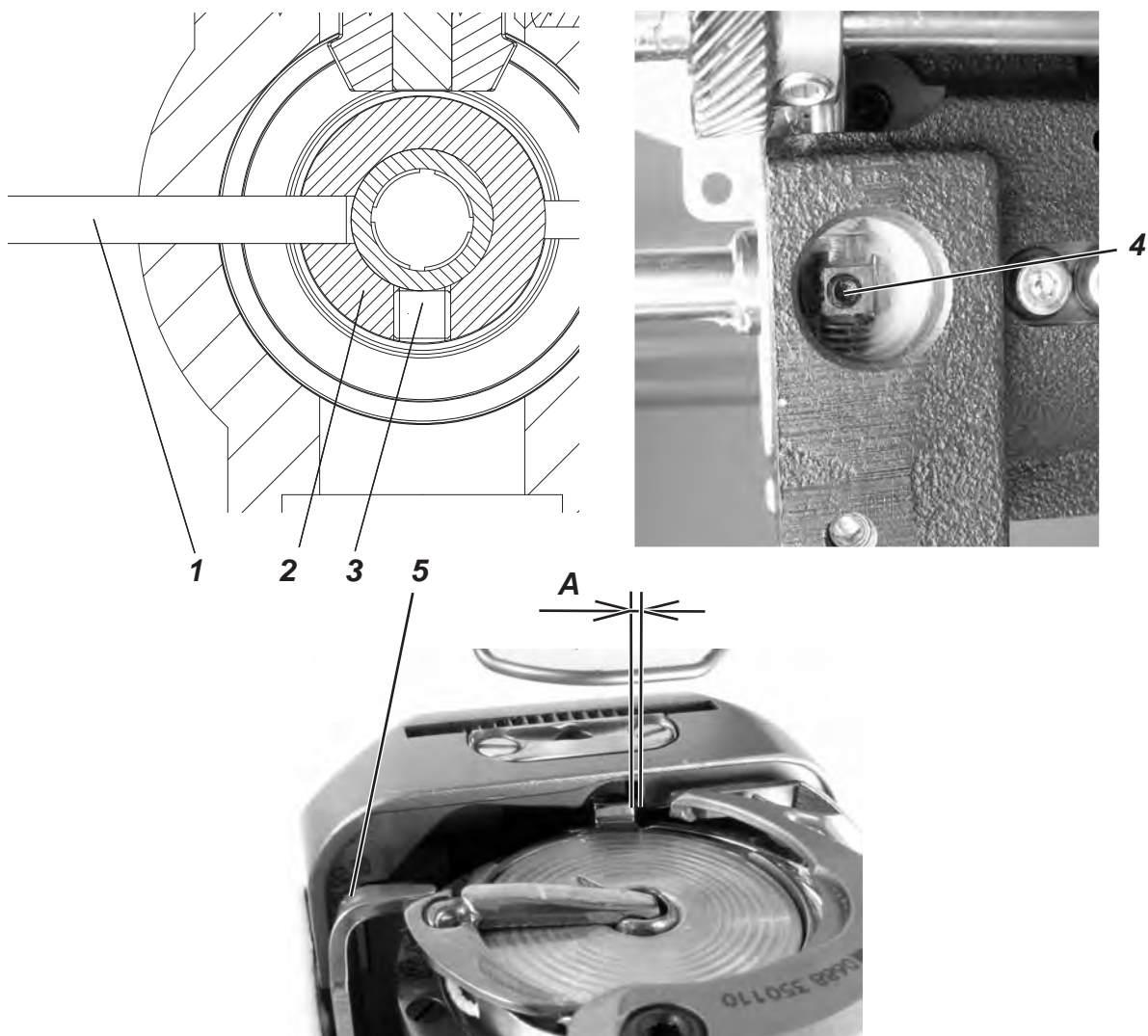

- Insert the retention pin (1) in the lifting cam (2). This is at the rear for the right hook column and at the front for the left hook column. Remove the lower plug. Loosen screw (3). Adjust the handwheel according to rule 1. Tighten screw (3).
- Turn the handwheel so the indicator points to 312. Remove the plug. Loosen screw (4). Turn the bobbin house lift (5) so that the available clearance distance (A) complies with rule 2. Tighten screw (4). Re-seal the openings.

## 4.5 Hook lubrication

### Rule:

1. Between the lubricating fitting (2) and the hook should be a distance of **(A) = 0.3 mm**.
2. The setting screw (3) of the lubrication should proceed **0.5 mm** out of the lubricating fitting.

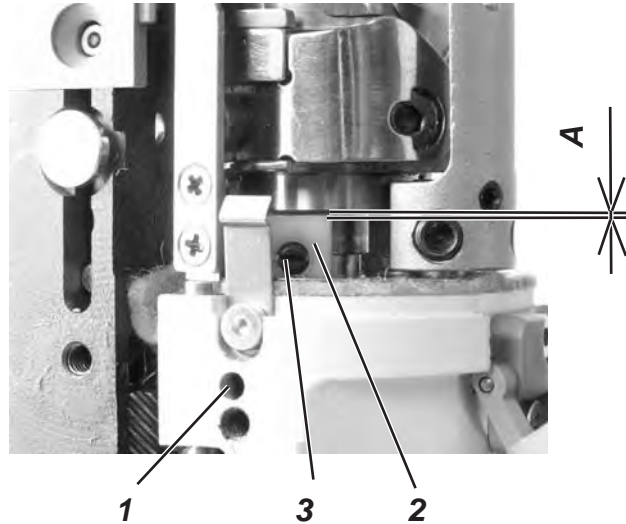

- Loosen screw (1), set the height of the lubricating fitting (2) to the distance measure **(A)** according to rule 1 and tighten screw (1). This procedure accomplishes rule 1.
- Screw in screw (3) according to rule 2.
- In order to throttle the lubrication, screw in deeper the screw (3), but not any further than **0.5 mm** below the surface of the lubricating fitting (2).



### Caution: Danger of injury !

Turn the main switch off.

Proceed with the setting of the hook lubrication only with the sewing machine switched off.

## 5. Thread setting

### 5.1 Thread regulator, check spring, bolt for the thread lever mechanism

#### Rules:

1. The rightmost edge of the thread regulator (1) should align with the number 4 on the scale.
2. The check spring (5) should be set to the distance measure of **(A) = 10 to 12 mm**. The range of movement for the check spring is about **30°**.
3. The slot position of the bolt (8) should form an angle of **25°** (refer to the illustration).

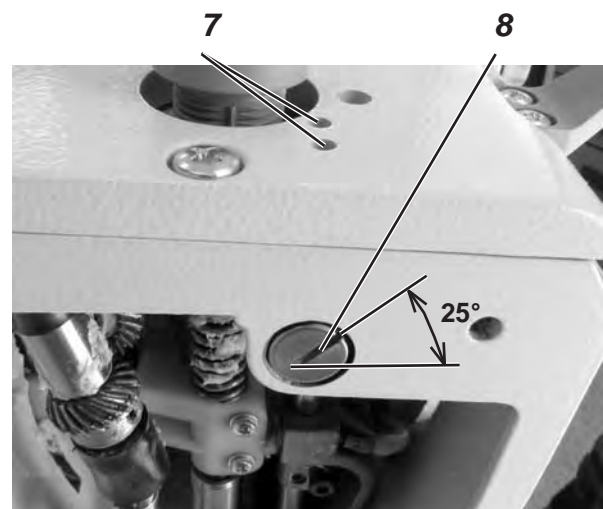
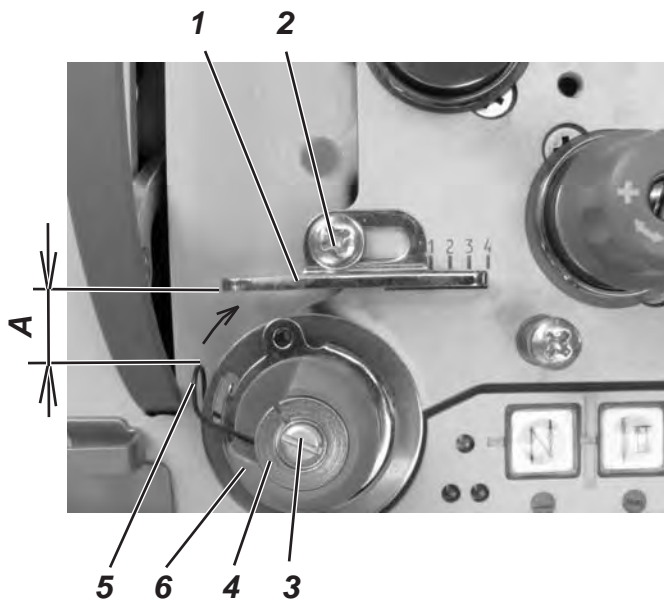

- Loosen screw (2). Push the thread regulator (1) to number 4, according to rule 1. Tighten screw (2).
- Loosen screw (3). Turn stop sleeve (4) in the direction of arrow, until the thread take-up lever (5) is separated from the body (6). Turn the stop sleeve (4) in the opposite direction as the arrow. Turn until the thread take-up lever touches the body (6). Turn both parts (4) and (6) together until the clearance distance **(A)** is reached. Hold the body (6) tight while turning the stop sleeve (4) for **30°** opposite the direction shown by the arrow. Hold (4) and (6) while tightening screw (3).
- Insert 3-mm hexagon socket wrench into hole (7) and loosen screws. Position the bolt (8) according to rule 3. Tighten screws (7).



## 5.2 Bobbin winder

### Rule:

1. When the bobbin winder is switched off, the distance between bobbin winder wheel and belt pulley should be **(A) = 0.8 mm**.
2. The winding procedure should stop automatically, when the bobbin is filled up to **0.5 mm** underneath the the bobbin edge.

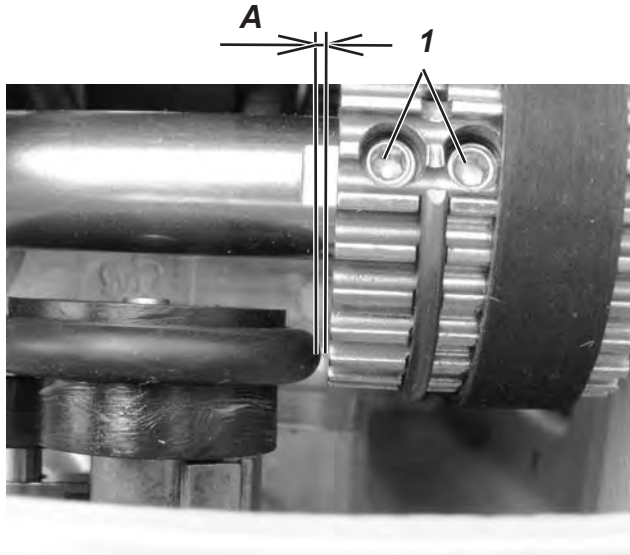

- Turn the belt pulley to the top using the screws (1). Push the toothed belt to the right so that both screws (1) are accessible. Loosen screws (1) and set the distance measure **(A)** according to rule 1, tighten screws (1).
- Determine the bobbin filling by adjusting screw (2). Screw in screw (2) for 1 to 2 mm, but a bobbin on the bobbin winder shaft and wind on thread. Check the filling level as soon as the bobbin winder turns off. If necessary, change the position of the screw (2) until rule 2 is fulfilled.

## 6. Thread cutter

### 6.1 Thread cutter height, position of the counter knife

#### Standard checking

1. The distance measure between the thread-pulling knife (5) and the hook should be **(A) = 0.2 mm**.
2. The distance measure between the counter knife (6) and the thread-pulling knife (5) should be **(B) = 0.3 to 0.5 mm**.
3. The knives should have contact at the distance **(C) = 1 to 2 mm**.

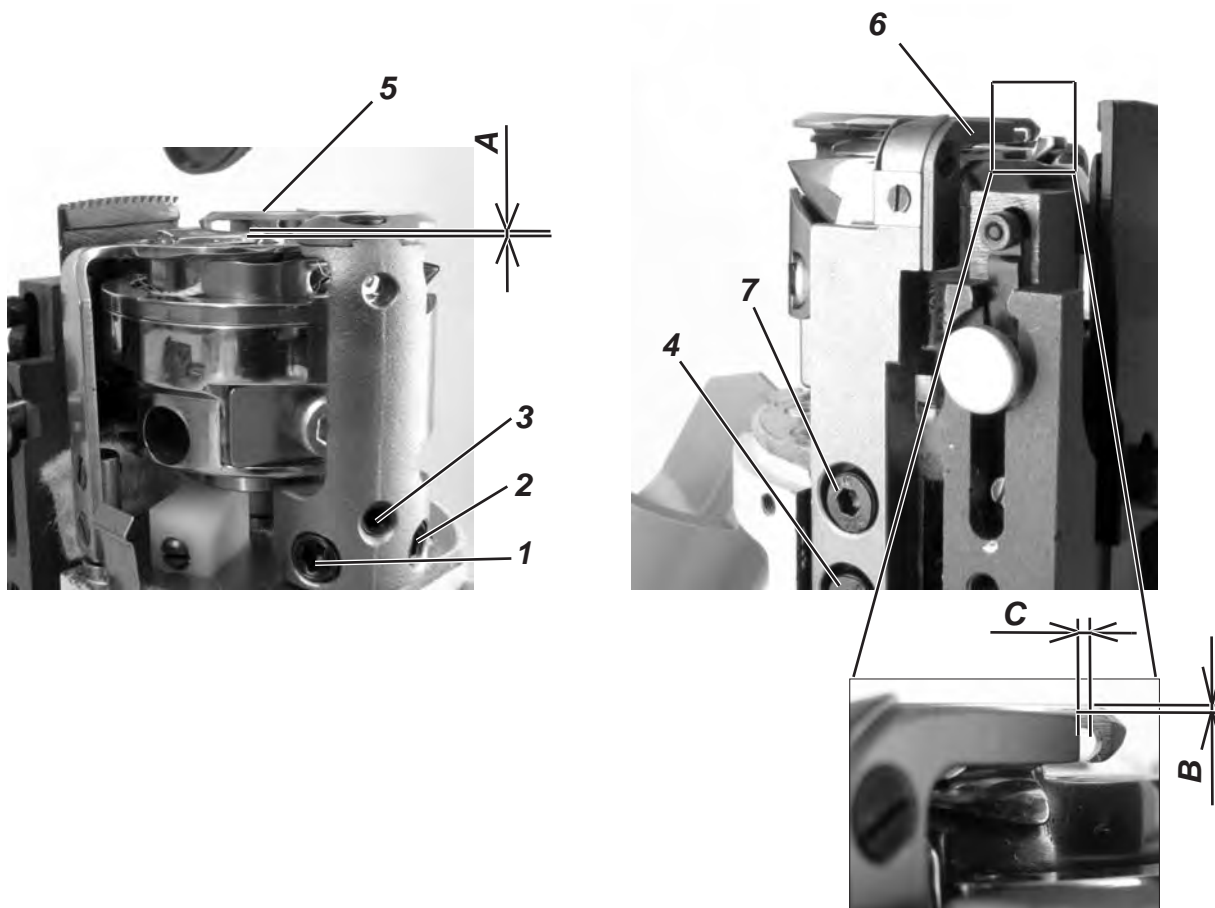

- Loosen screws (1), (2), (3) and push the holder (4) downwards.
- Slightly tighten screw (2), that sits on the surface of the shaft.
- Tighten screw (3) until the distance measure **(A) = 0.2 mm** is set and thus rule 1 is accomplished.
- Tighten screw (2) and afterwards also screw (1).
- Dismount the column protection.
- Loosen screws (7) and (4). Set the distance measure **(B) = 0.3 to 0.5 mm** according to rule 2.
- Slightly tighten screw (4).
- Turn the handwheel, so that the index points to degree "270" .
- Turn the thread-pulling knife (5) manually to set it to the distance measure **(C) = 1 to 2 mm** and adjust the counter knife (6) accordingly until the knives touch smoothly (without any pressure).
- Tighten screws (7) and (4) and check whether the knives touch at the distance **(C)**.

## 6.2 Starting position of the thread-pulling knife

### Rule:

When the roller (1) is in the highest point of the control cam (2) the end of the thread-pulling knife (3) should overrun the blade of the counter knife (4) of **0.5-1 mm**.

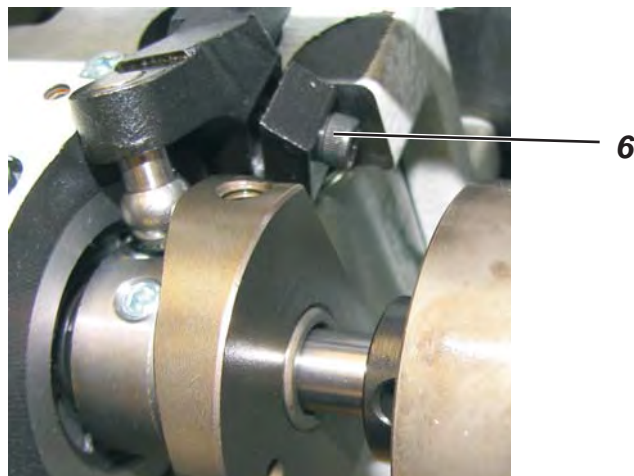
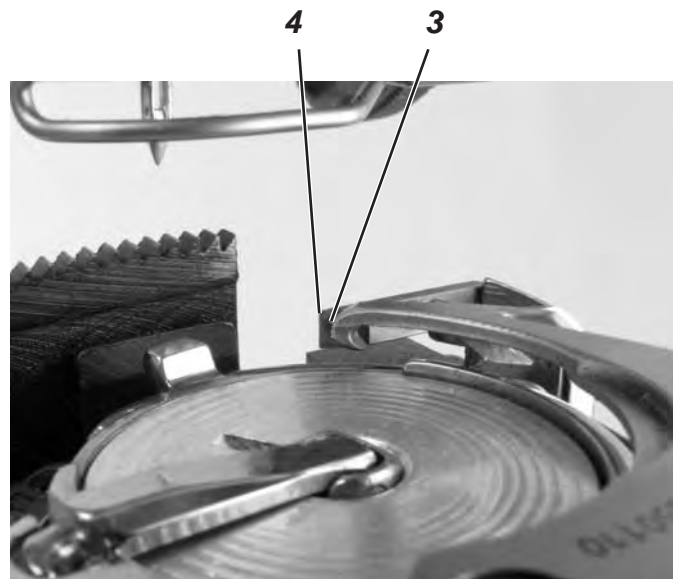
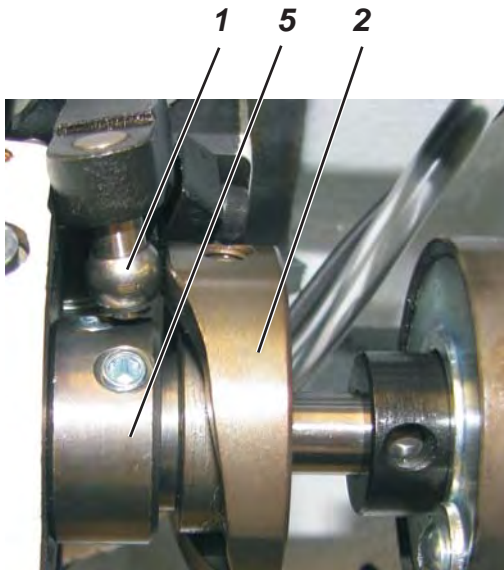

- Check whether the control cam (2) butts against the ring (5).
- Position the control cam according to the rule.
- Loosen screw (6).
- Set the thread-pulling knife (3) according to the rule.
- Tighten screw (6).



### Caution: Danger of injury !

Turn the main switch off.

Proceed with the thread cutter setting only with the sewing machine switched off.

## 6.3 Control cam

### Rule:

1. There should be a clearance distance (**A**) = **0.05 to 0.1 mm** between the highest point on the control cam (1) and the roller (2).
2. The threads should be separate when the pointer on the handwheel points from "40" to "45" on the scale.

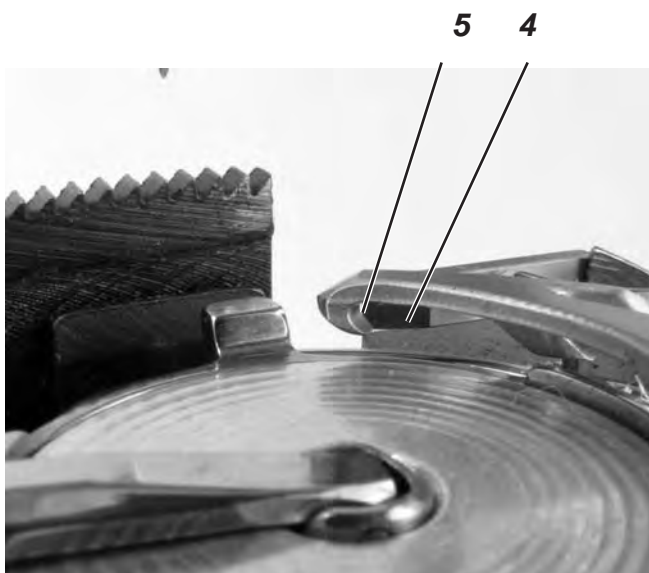
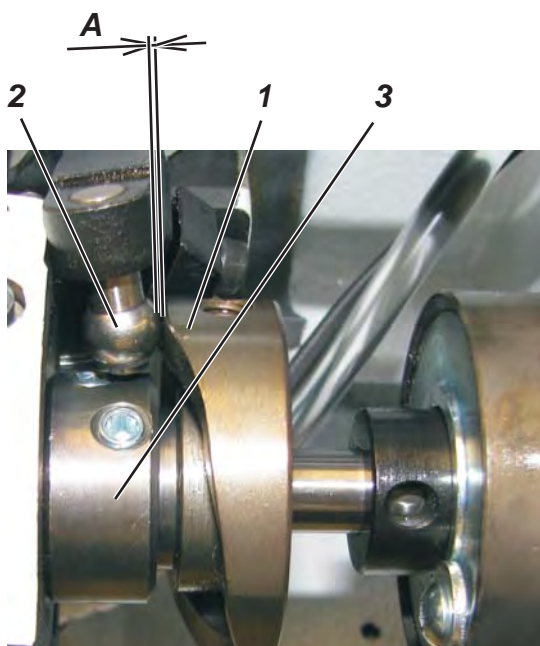

- Loosen the screws of the ring (3).
- Loosen the screws of the cam (1).
- Turn the cam (1) with its top against the roller (2). Shift the cam laterally so that the distance between the cam and the roller is **(A) = 0.05 – 0.1 mm**.
- Shift the ring (3) to the right towards the cam (1) until it stops. Take care that the hook timing (par. 4.2) is not destroyed.
- Tighten the ring (3) screws.
- Tighten the cam (1) screws so that the trimming knife (4) edge and the fixed knife (5) edge flush at 40° - 45° on the hand wheel.
- Check the setting of the distance according to rule 1, cam angle according to rule 2, and hook timing according to par. 4.2.



### Caution: Risk of injury!

Turn the main switch off.

Proceed with the setting of the control cam only with the sewing machine switched off.

## 6.4 Bobbin thread clamp

### Rule:

The clamping force of the spring (1) should not be set higher than needed. It should just be able to pull out the lower thread from the hook.

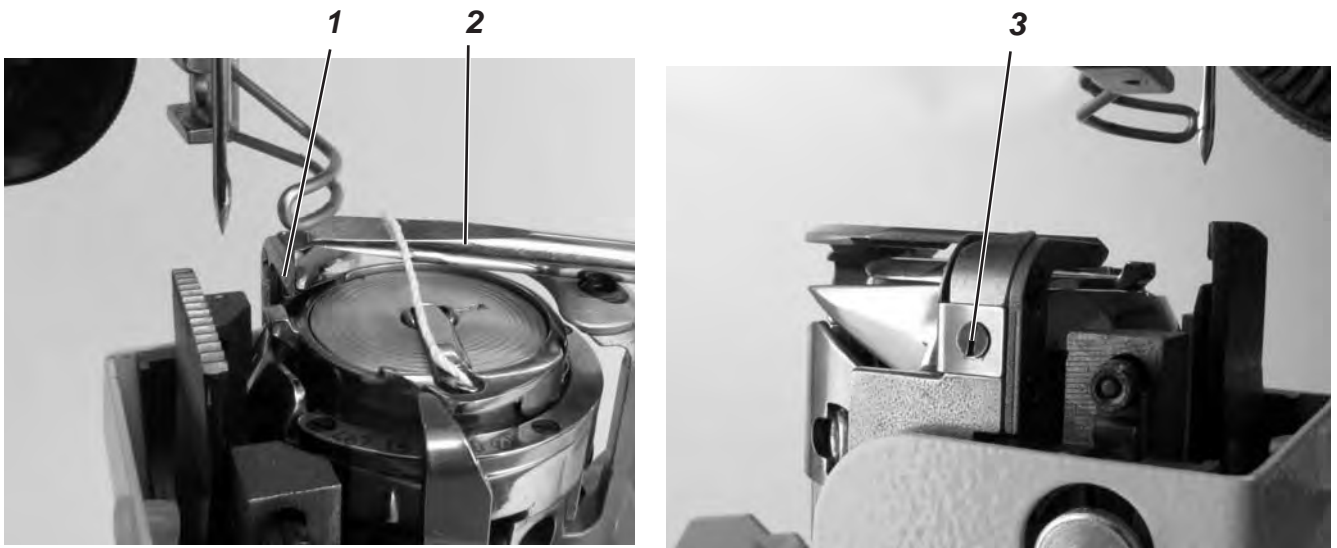

- Sew and cut the threads.
- Using a screwdriver (2), inspect the thread according the illustration. Check if the thread is being pulled out of the bobbin winder or from the clamping (1).
- Using screw (3), control and adjust the spring pressure (1) until the rule is fulfilled.



### Caution: Risk of injury!

Turn the main switch off.

Only adjust the clamping spring when the machine is turned off.



### CAUTION!

Sewing problems can result when the clamping spring is improperly adjusted.

## 7 Electronic control and sewing machine drive - positioning motor

All operating instructions and parameter sheets are available at the manufacturers' websites (see [www.efka.net](http://www.efka.net), [www.duerkopp-adler.com](http://www.duerkopp-adler.com), [www.hohsing.com](http://www.hohsing.com), etc.).

Selected instructions concerning the control and drive setting needed for the operators are included in the Operating instructions.

Selected instructions needed for the technician to set the drive are included in the Operating instructions.

### Important notes concerning electrostatic discharges (ESD)



#### Caution!

Before effectuating any works on electronic components: Turn off the main switch. Remove the plug from the socket.

Electrostatic discharges can cause damage to PCBs and other components. You can obtain a certain protection by wearing anti-static gloves or wrist-wraps that you can connect for grounding on the mass of any unpainted metal piece of the machine head or on the switch cabinet.

Handle the PCBs with utmost caution. They are very sensitive towards electrostatic discharges. Hold the PCBs only at their edges.

Put the PCBs after unwrapping or after dismantling with their components upside onto a grounded statically discharged surface. We recommend to use a conductive foam underlay but not as the protective cover of the PCB.

Pay attention not to pull the PCBs over any surface.

## 7.1 Terminals to PCB connections - electromagnetic variant

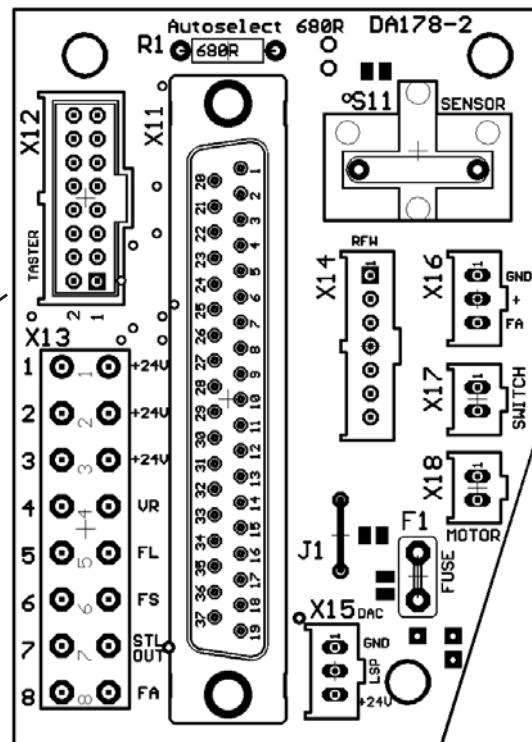
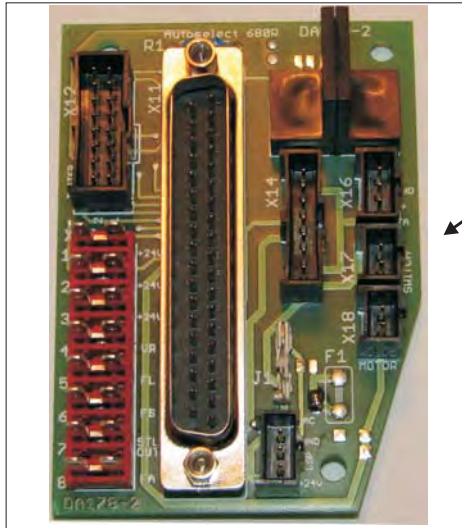

### Description of DA178-2 (9850 688001) switchboard connection

X11 - main connection cable to control unit

X12 - keypad (Taster)

X13 - terminals for solenoid connection

1,2,3 – supply voltage +24V

4 - VR (backtacking)

5 - FL (foot lifting)

6 - FS (thread tensioner)

7 - STL OUT (half stitch)

8 - FA (thread trimmer)

X14 - bobbin thread monitor

X15 - connection of side switchboard when using DAC control  
(with cable 9870 867018)

X16\* - connection of connecting cable 9870 688002 for connector on base plate  
(thread trimmer solenoids, sewn material edge horizontal trimmer)

X17 - microswitch of sewn material edge trimmer (vertical, oblique)

X18 - sewn material edge trimmer motor

F1 - sewn material edge trimmer resettable fuse

R1 - Autoselect resistor (sewing machine class selection)

S11 - tilt sensor

J1 - switch; if the sewing machine has a direct drive (DAC control, side switchboard), switch J1 off, otherwise switch J1 on.

\* Connection of edge trimmer solenoids to the grey connector on the base plate is to be made between FA and + (white and brown).

Connection of the horizontal edge trimmer is to be made between + and GND (brown and green).

## 7.2 Terminals to PCB connections - pneumatic variant

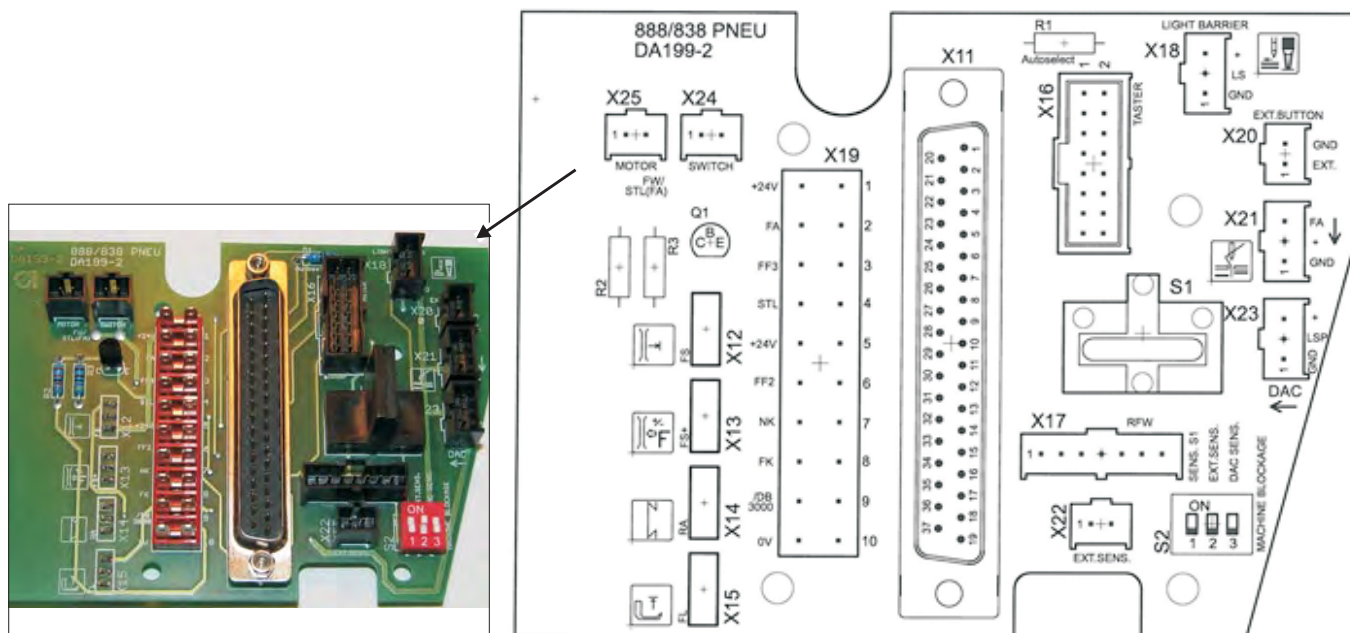

### Description of DA199\_2 (9850 838000) switchboard

- X11 - 37-pole connector (to control box)
- X12 - thread tensioner valve
- X13 - secondary thread tensioner valve
- X14 - bartacking valve
- X15 - sewing foot valve
- X16 - keypad
- X17 - bobbin thread monitor
- X18 - light barrier
- X19 - 1. +24V  
2. FA (thread trimming)  
3. FF3 (functional outlet 3, e. g. puller, pneumatic material edge trimmer)  
4. STL (stitch length valve)  
5. +24V  
6. FF2 (functional outlet 2)  
7. NK (needle cooling)  
8. FK (thread clamp)  
9. /DB3000 (needle switch off)  
10. 0V
- FW/STL(FA) – auxiliary outlet (thread wiper/zero stitch length at thread trimming)
- X20 - external outlet controlled with auxiliary pushbutton on keypad ( $I_{max}=50mA$ )
- X21 - connection of auxiliary cable for bottom distribution (FA, +24V, GND)
- X22 - external blocking of operation (e. g. thread lever guard switch, etc.)
- X23 - connection of a side DAC switchboard (direct drive)
- X24 - material edge trimmer microswitch
- X25 - material edge trimmer mini motor
- S1 - tilt sensor
- S2 - sewing machine operation blocking mode; switch in ON position means that the sensor is without function
- SENS. S1 = tilt sensor on switchboard; EXT.SENS. = sensor in connector X22
- DAC SENS. = sensor on DAC side switchboard (direct drive)







DÜRKOPP ADLER GmbH  
Potsdamer Str. 190  
33719 Bielefeld  
Germany  
Phone +49 (0) 521 925 00  
E-Mail: [service@duerkopp-adler.com](mailto:service@duerkopp-adler.com)  
[www.duerkopp-adler.com](http://www.duerkopp-adler.com)