



743-221-01

Operating Instructions

IMPORTANT
READ CAREFULLY BEFORE USE
KEEP FOR FUTURE REFERENCE

All rights reserved.

Property of Dürkopp Adler AG and protected by copyright. Any reuse of these contents, including extracts, is prohibited without the prior written approval of Dürkopp Adler AG.

Copyright © Dürkopp Adler AG 2018

1	About these instructions	3
1.1	For whom are these instructions intended?	3
1.2	Representation conventions – symbols and characters	3
1.3	Other documents	5
1.4	Liability.....	5
2	Safety	7
2.1	Basic safety instructions	7
2.2	Signal words and symbols used in warnings.....	8
3	Machine description	11
3.1	Components of the machine.....	11
3.2	Software description	12
4	Operation.....	13
4.1	Preparing the machine for operation	13
4.2	Switching on and off the machine.....	14
4.3	Changing the needle	15
4.4	Threading the needle thread	16
4.5	Winding the hook thread.....	17
4.6	Changing the bobbin	18
4.7	Hook thread counter	18
4.8	Thread tension.....	19
4.8.1	Setting the needle thread tension.....	20
4.8.2	Setting the hook thread tension	21
4.9	Needle thread monitor	22
4.10	Setting the needle thread regulator	23
4.11	Remaining thread monitor	24
4.12	Changing the template set.....	25
4.13	Setting the working range, angle and length	26
4.14	Setting the insertion depth of the folding table	28
4.15	Sewing.....	29
5	Programming	31
5.1	Main Menu.....	31
5.2	Submenu	32
5.2.1	Navigating in the submenu	32
5.2.2	Settings in the submenu	33
5.3	Installing the machine software	36
5.3.1	Loading the program	37
5.3.2	Dongle-Update via Internet.....	38
6	Maintenance.....	39
6.1	Swiveling up the machine head.....	40
6.2	Cleaning	41
6.2.1	Cleaning the machine head.....	41
6.2.2	Cleaning the motor fan sieve.....	42
6.3	Lubricating	43
6.3.1	Checking the machine head lubrication.....	44
6.3.2	Checking the hook lubrication	44
6.4	Servicing the pneumatic system.....	45
6.4.1	Setting the operating pressure	45

6.4.2	Draining the water condensation	46
6.4.3	Cleaning the filter element	47
6.5	Parts list	48
7	Setup.....	49
7.1	Checking the scope of delivery	49
7.2	Removing the transport locks	49
7.3	Installing the machine	50
7.3.1	Transport	50
7.3.2	Lifting the machine	50
7.3.3	Rolling the machine	50
7.4	Setting the working height	52
7.5	Assembling the thread reel holder	53
7.6	Assembling the holding device for the template set	54
7.7	Assembling the operating panel OP3000	55
7.8	Electrical connection.....	56
7.9	Pneumatic connection	57
7.9.1	Assembling the compressed air maintenance unit	57
7.9.2	Setting the operating pressure	58
7.10	Performing a test run	58
8	Decommissioning.....	59
9	Disposal.....	61
10	Troubleshooting	63
10.1	Customer Service	63
10.2	Messages of the software.....	63
10.3	Errors in sewing process	64
11	Technical data.....	67
12	Appendix	69

1 About these instructions



These instructions have been prepared with utmost care. They contain information and notes intended to ensure long-term and reliable operation.

Should you notice any discrepancies or if you have improvement requests, then we would be glad to receive your feedback through **Customer Service** ( p. 63).

Consider the instructions part of the product and store them in a place where they are readily available.

1.1 For whom are these instructions intended?

These instructions are intended for:

- **Operators:**
This group is familiar with the machine and has access to the instructions. Specifically, chapter **Operation** ( p. 13) is important for the operators.
- **Specialists:**
This group has the appropriate technical training for performing maintenance or repairing malfunctions. Specifically, the chapter **Setup** ( p. 49) is important for specialists.

Service Instructions are supplied separately.

With regard to minimum qualification and other requirements to be met by personnel, please also follow the chapter **Safety** ( p. 7).

1.2 Representation conventions – symbols and characters

Various information in these instructions is represented or highlighted by the following characters in order to facilitate easy and quick understanding:



Proper setting

Specifies proper setting.



Disturbances

Specifies the disturbances that can occur from an incorrect setting.



Cover

Specifies which covers must be disassembled in order to access the components to be set.



Steps to be performed when operating the machine (sewing and

equipping)



Steps to be performed for service, maintenance, and installation



Steps to be performed via the software control panel

The individual steps are numbered:

1. First step
 2. Second step
 - ...
- The steps must always be followed in the specified order.
- Lists are marked by bullet points.



Result of performing an operation

Change to the machine or on the display/control panel.



Important

Special attention must be paid to this point when performing a step.



Information

Additional information, e.g. on alternative operating options.



Order

Specifies the work to be performed before or after a setting.

References



Reference to another section in these instructions.

Safety

Important warnings for the user of the machine are specifically marked. Since safety is of particular importance, hazard symbols, levels of danger and their signal words are described separately in the chapter **Safety** (📖 p. 7).

Location information

If no other clear location information is used in a figure, indications of **right** or **left** are always from the user's point of view.

1.3 Other documents

The machine includes components from other manufacturers. Each manufacturer has performed a hazard assessment for these purchased parts and confirmed their design compliance with applicable European and national regulations. The proper use of the built-in components is described in the corresponding manufacturer's instructions.

1.4 Liability

All information and notes in these instructions have been compiled in accordance with the latest technology and the applicable standards and regulations.

Dürkopp Adler cannot be held liable for any damage resulting from:

- Breakage and damage during transport
- Failure to observe these instructions
- Improper use
- Unauthorized modifications to the machine
- Use of untrained personnel
- Use of unapproved parts

Transport

Dürkopp Adler cannot be held liable for breakage and transport damages. Inspect the delivery immediately upon receiving it. Report any damage to the last transport manager. This also applies if the packaging is not damaged.

Leave machines, equipment and packaging material in the condition in which they were found when the damage was discovered. This will ensure any claims against the transport company.

Report all other complaints to Dürkopp Adler immediately after receiving the product.

2 Safety

This chapter contains basic information for your safety. Read the instructions carefully before setting up or operating the machine. Make sure to follow the information included in the safety instructions. Failure to do so can result in serious injury and property damage.



2.1 Basic safety instructions

The machine may only be used as described in these instructions.

These instructions must be available at the machine's location at all times.

Work on live components and equipment is prohibited. Exceptions are defined in the DIN VDE 0105.

For the following work, switch off the machine at the main switch or disconnect the power plug:

- Replacing the needle or other sewing tools
- Leaving the workstation
- Performing maintenance work and repairs
- Threading

Missing or faulty parts could impair safety and damage the machine. Only use original parts from the manufacturer.

Transport Use a lifting carriage or forklift to transport the machine. Raise the machine max. 20 mm and secure it to prevent it from slipping off.

Setup The connecting cable must have a power plug approved in the relevant country. The power plug may only be assembled to the power cable by qualified specialists.

Obligations of the operator Follow the country-specific safety and accident prevention regulations and the legal regulations concerning industrial safety and the protection of the environment.

All the warnings and safety signs on the machine must always be in legible condition. Do not remove!

Missing or damaged warnings and safety signs must be replaced immediately.

Requirements to be met by the personnel Only qualified specialists may:

- set up the machine / put the machine in operation
- perform maintenance work and repairs
- perform work on electrical equipment

Only authorized persons may work on the machine and must first have understood these instructions.

Operation Check the machine during operating for any externally visible damage. Stop working if you notice any changes to the machine. Report any changes to your supervisor. Do not use a damaged machine any further.

Safety equipment Safety equipment should not be removed or deactivated. If it is essential to remove or deactivate safety equipment for a repair operation, it must be assembled and put back into operation immediately afterward.



2.2 Signal words and symbols used in warnings



Warnings in the text are distinguished by color bars. The color scheme is based on the severity of the danger. Signal words indicate the severity of the danger.

Signal words Signal words and the hazard they describe:

Signal word	Meaning
DANGER	(with hazard symbol) If ignored, fatal or serious injury will result
WARNING	(with hazard symbol) If ignored, fatal or serious injury can result
CAUTION	(with hazard symbol) If ignored, moderate or minor injury can result
CAUTION	(with hazard symbol) If ignored, environmental damage can result
NOTICE	(without hazard symbol) If ignored, property damage can result

Symbols The following symbols indicate the type of danger to personnel:

Symbol	Type of danger
	General
	Electric shock

Symbol	Type of danger
	Puncture
	Crushing
	Environmental damage

Examples Examples of the layout of warnings in the text:

DANGER



Type and source of danger!

Consequences of non-compliance.

Measures for avoiding the danger.

↪ This is what a warning looks like for a hazard that will result in serious injury or even death if ignored.

WARNING



Type and source of danger!

Consequences of non-compliance.

Measures for avoiding the danger.

↪ This is what a warning looks like for a hazard that could result in serious or even fatal injury if ignored.

CAUTION



Type and source of danger!

Consequences of non-compliance.

Measures for avoiding the danger.

↪ This is what a warning looks like for a hazard that could result in moderate or minor injury if the warning is ignored.

CAUTION



Type and source of danger!

Consequences of non-compliance.

Measures for avoiding the danger.

-
- ↪ This is what a warning looks like for a hazard that could result in environmental damage if ignored.

NOTICE

Type and source of danger!

Consequences of non-compliance.

Measures for avoiding the danger.

-
- ↪ This is what a warning looks like for a hazard that could result in property damage if ignored.

3 Machine description

3.1 Components of the machine

Fig. 1: Components of the machine



3.2 Software description

Fig. 2: Software description

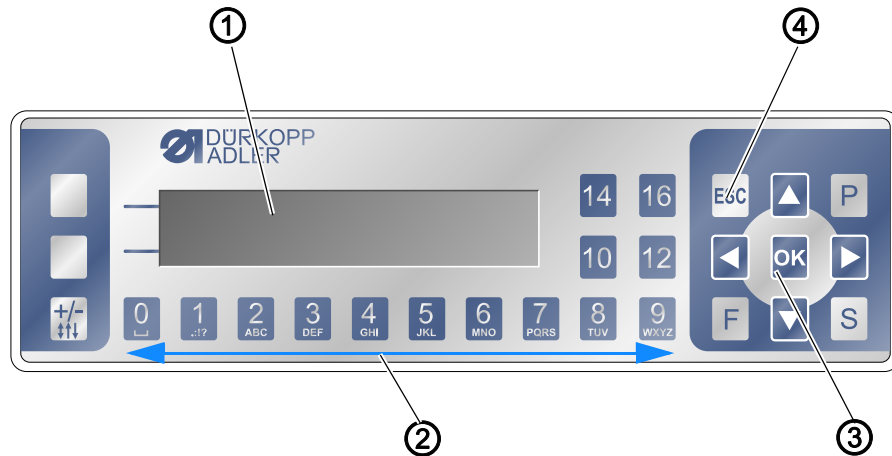

- (1) - Display
 (2) - Numeric keys
 (3) - Escape key
 (4) - OK key

The settings of the control unit are effectuated via the operating panel OP3000. Here is a summary of some important possibilities for navigation:

Key/key group	Function
1 to 6	Switching on and off the functions shown in the display above.
Arrow keys (◀, ▶)	Navigating in the main menu
Arrow keys (▲, ▼)	Increasing or decreasing values/parameters
OK	Short keystroke confirms a selection Long keystroke resets f.e. the piece counter or the bobbin thread counter
ESC	No function in the main menu, but relevant in the sub-menu

4 Operation

The operating sequence consists of several different steps.
Fault-free operation is necessary in order to achieve a good sewing result.

4.1 Preparing the machine for operation

WARNING



Risk of injury from moving, cutting and sharp parts!

Crushing, cutting and punctures are possible.

If possible, make preparations only when the machine is switched off.

Complete the following steps in preparation of sewing before starting to work:

- Inserting/changing the needle
- Threading the needle thread
- Inserting and winding on the hook thread
- Setting the thread tension

4.2 Switching on and off the machine

Fig. 3: Switching on and off the machine

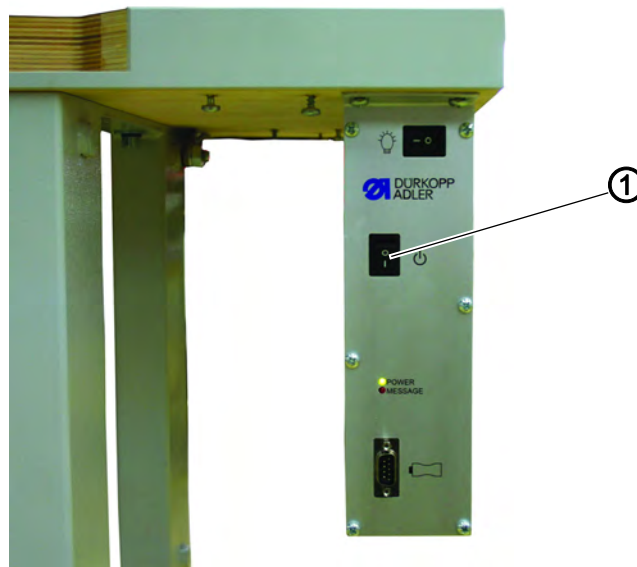

(1) - Main switch



To switch on the machine:

1. Turn on the main switch (1).
- ↳ The control is initialized.
The sewing unit calls for a reference run.
2. Press the **OK** key on the control panel.
- ↳ The reference run is carried out.
The machine is ready for operation.



To switch off the machine:

1. Turn off the main switch (1).
- ↳ The sewing unit is cut off the power supply.
It is **no longer** ready for operation.

4.3 Changing the needle

Fig. 4: Changing the needle

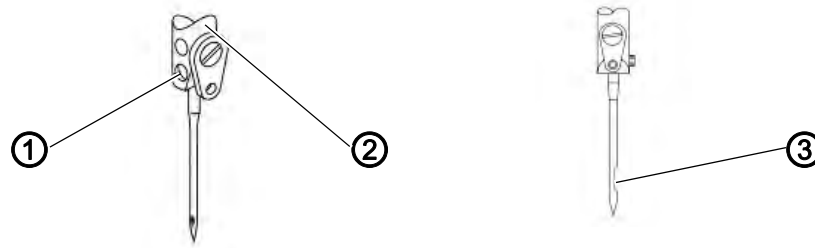

(1) - Screw

(2) - Needle bar

(3) - Groove



To change the needle:

1. Loosen screw (1) and remove the needle.
2. Push the new needle into the drill-hole of the needle holder (2) as far as it will go.



Important

Seen from the machine operator's side the needle scarf (3) should point to the right, i. e. to the hook tip (see sketch).

3. Tighten screw (1).

4.4 Threading the needle thread

Fig. 5: Threading the needle thread



To thread the needle thread:

1. Thread the needle thread as shown above.

4.5 Winding the hook thread

Fig. 6: Winding the hook thread

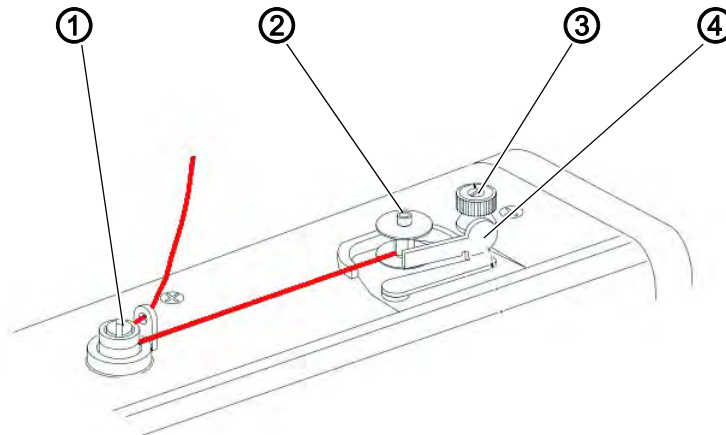

(1) - Bobbin thread tension
(2) - Winder shaft

(3) - Trimming clamp
(4) - Winder clip



To wind the hook thread:

1. For a trouble-free functioning of the residual thread monitor always remove any thread waste from the bobbin hub before winding.
 2. Thread the hook thread according to the picture.
 3. Prewind the hook thread in clockwise direction into the reserve groove of the bobbin hub.
 4. Fit the bobbin on the winder shaft (2).
 5. Pull the thread end through the trimming clamp (3) and cut it off.
 6. Swivel the winder clip (4) against the bobbin.
 7. Set the bobbin thread tension (1).
Wind on the hook thread with minimum tension.
 8. Turn the main switch on.
 9. Start the sewing process.
- ⚡ After reaching the set bobbin filling level the winder stops automatically.

4.6 Changing the bobbin

Fig. 7: Changing the bobbin

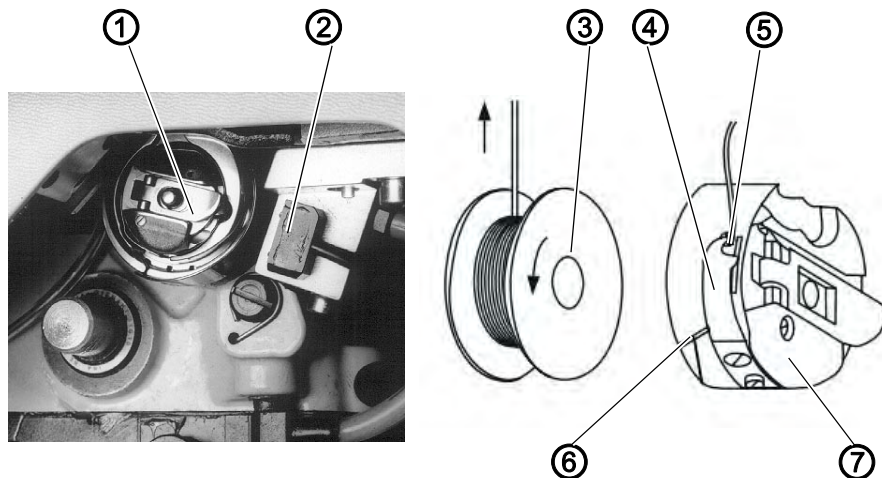

- (1) - Bobbin case flap
- (2) - Light barrier
- (3) - Bobbin
- (4) - Tension spring

- (5) - Drill hole
- (6) - Slot
- (7) - Upper bobbin case



To change the bobbin:

1. Lift the bobbin case flap (1).
2. Remove the upper bobbin case (7) with the bobbin (3).
3. Remove the empty bobbin (3) from the upper bobbin case (7).
4. Insert a full bobbin (3) into the upper bobbin case (7).
5. Pull the hook thread through the slit (6) underneath the tension spring (4) into the drill-hole (5).
6. Pull about 5 cm of hook thread out of the upper bobbin case (7). When pulling the thread, the bobbin (3) should turn into the direction indicated by the arrow.
7. Insert the upper bobbin case (7) back into the hook, make sure the bobbin case flap (1) snaps into place.
8. Turn on the main switch.
9. Start a new sewing cycle.

4.7 Hook thread counter

The remaining number of hook thread stitches is indicated on the display, see (📖 p. 31).

Resetting the hook thread counter



To reset the hook thread counter:

1. Select the symbol hook thread counter with the arrow keys.
2. Effectuate a long stroke on the **OK** key.
- ↵ The counter is reset to its initial values.

4.8 Thread tension

Together with the hook thread tension, the needle thread tension influences the final seam pattern. With thin sewing material, excessive thread tension can lead to undesired gathering and thread breakage.



Proper setting

If the tension of needle thread and hook thread is identical, the thread interlacing lies in the middle of the sewing material.

Set the needle thread tension so that the desired seam pattern is achieved with the lowest possible tension.

Fig. 8: Thread tension

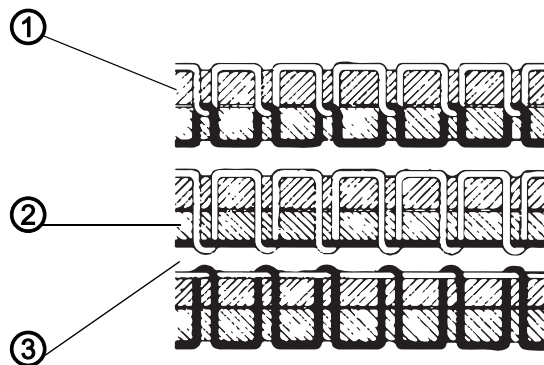

- (1) - Identical needle thread and hook thread tension
- (2) - Hook thread tension higher than needle thread tension
- (3) - Needle thread tension higher than hook thread tension

4.8.1 Setting the needle thread tension

Fig. 9: Setting the needle thread tension



(1) - Main tension

The main tensioner (1) should generate the adequate needle thread tension for the particular material and needle thread



To set the needle thread tension:

1. Turn the knurled nut.
 - Increase the needle thread tension: turn the knurled nut clockwise
 - Decrease the needle thread tension: turn the knurled nut counterclockwise

4.8.2 Setting the hook thread tension

Fig. 10: Setting the hook thread tension

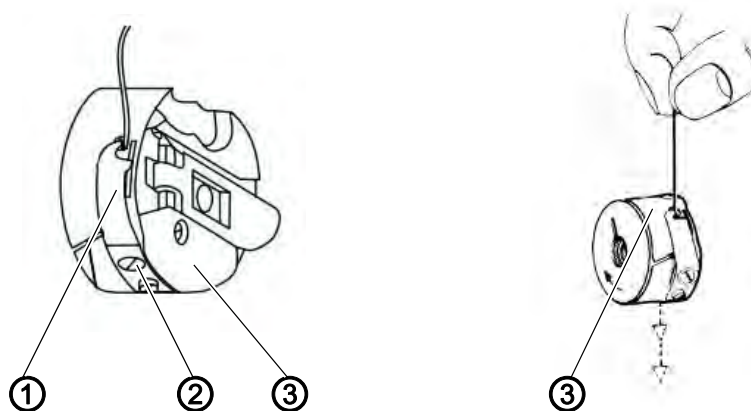

(1) - Tension spring
(2) - Adjusting screw

(3) - Upper bobbin case

The necessary hook thread tension is generated by the tension spring (1).



To set the bobbin thread tension:

1. Insert a full bobbin in the upper bobbin case (3).
2. Thread in the hook thread.
3. Set the tension spring (1) at the adjustment screw (2).

↳ **Guide value:** The hook thread tension should be about 20-30 g.
The bobbin case should slowly sink down through its own weight.

4.9 Needle thread monitor

Fig. 11: Needle thread monitor

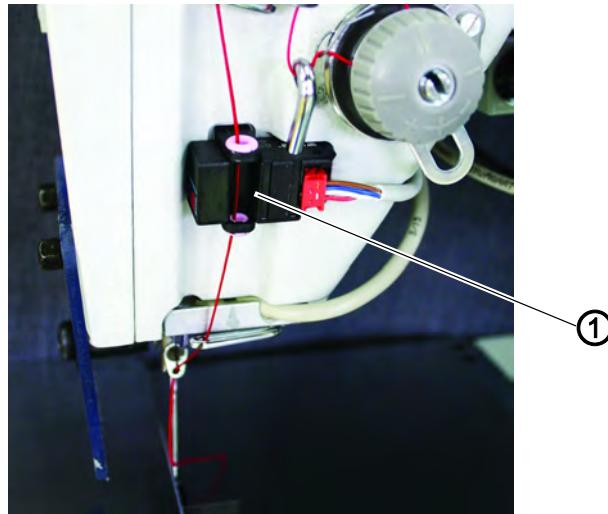

(1) - Needle thread monitor

At needle thread rupture, a rupture message will appear on the display and the machine stops.



To use the needle thread monitor:

1. Turn the machine off the main switch.
2. Remove the unfinished workpiece.
3. Thread the needle thread ( p. 16).
4. Turn on the machine.
5. Start a new sewing cycle.

4.10 Setting the needle thread regulator

Fig. 12: Setting the needle thread regulator

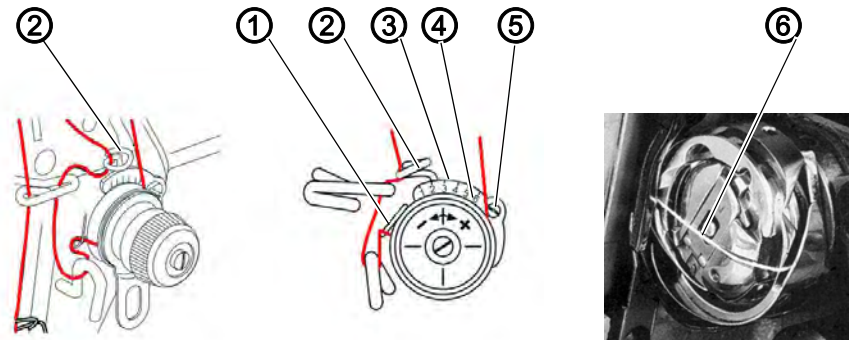

- | | |
|-------------------------------|--------------------------|
| (1) - Thread take-up spring | (4) - Scale |
| (2) - Needle thread regulator | (5) - Screw |
| (3) - Wire | (6) - Needle thread loop |

The needle thread regulator (2) controls the quantity of thread required for the stitch formation.

The needle thread regulator has to be precisely adjusted for an optimum sewing result.

The setting of the needle thread regulator depends on the following factors:

- Stitch length
- Thickness of the material
- Characteristics of the yarn utilized

With correct setting the needle-thread loop (6) should slide without any overrun and with low tension over the thickest point of the hook.



To set the needle thread regulator:

1. Loosen screw (5).
2. Set the needle thread regulator (2).
- ↳ The vertical wire (3) serves in conjunction with the scale (4) as adjusting aid (**guide value: 2.5**).
3. Tighten screw (5).



Information

The needle thread regulator (2) is correctly adjusted if:

The thread take-up spring (1) is pulled down about 1 mm from its upper final position, when the thread loop (6) passes the maximum hook breadth.

The length of 1 mm is an approximative guide value. Depending on the tension of the thread take-up spring it may be higher or lower.

4.11 Remaining thread monitor

The remaining thread monitor controls the thread reserve on the hook thread bobbin via reflecting infrared light barrier (1).

Fig. 13: Remaining thread monitor

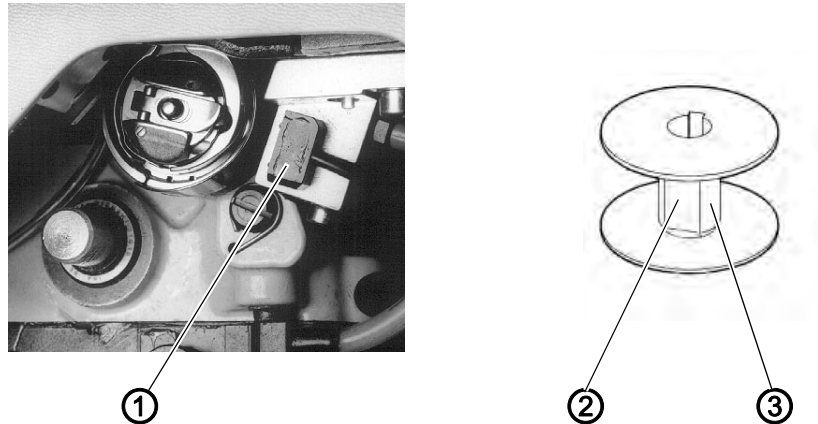

(1) - Light barrier
(2) - Reflecting surface

(3) - Bobbin hub

After a certain number of seams the hook thread quantity on the bobbin is used up.

The light beam transmitted by the light barrier (1) is reflected by the exposed reflecting surface (2) of the bobbin hub (3).

The display of the control unit shows a corresponding message.

The seam is safely finished with the thread remaining in the reserve groove.



To use the remaining thread monitor:

1. Turn off the main switch.
2. Change the bobbin



Important

Clean the lenses of the light barrier with a soft cloth after every bobbin change.

3. Switch on the machine.
4. Start a new sewing cycle.

4.12 Changing the template set

Fig. 14: Changing the template set

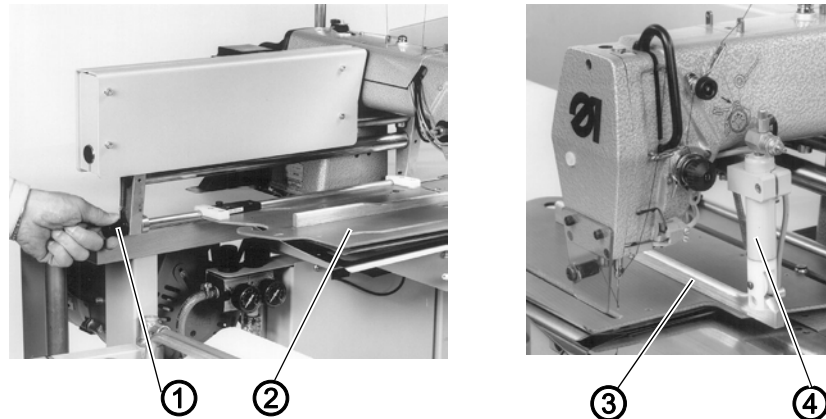

(1) - Handle
(2) - Template set

(3) - Control cam
(4) - Hold-down cylinder



To remove the template set:

1. Turn the handwheel until the needle stands in the 2nd position (UDC).
2. Slide the template set (2) into the left end position.
3. Turn the handle (1) about 90° in counter-clockwise direction.
4. Lift the template set (2) at the left side and carefully detach it from the transport carriage.
5. Remove the template set.



To insert the template set:

1. Turn the handwheel until the needle stands in the 2nd position (UDC).
2. Move the transport carriage to the left end position.
3. Bear the template set (2) with the right side carefully onto the transport carriage.
4. Turn the handle (1) 90° in counter-clockwise direction and lay the template set completely onto the transport carriage.
5. Turn back the handle (1).
- ↳ The template set is locked and safely fastened to the transport carriage.
6. Position the hold-down cylinder (4) with the guide roller on the control cam (3).
7. Slide the template set to the right as far as it will go.

4.13 Setting the working range, angle and length

The dart depth depends on:

- the individual template set
- the dart length
- the position of the folding table

The folding table can be continuously adjusted from 0-10°.

The dart depths for different inclinations and lengths are indicated in the diagrams.

The curve for the curved darts template set is also indicated.

Fig. 15: Setting the working range, angle and length



(1) - Scale

(2) - Handle



To set the inclination:

1. Retract the folding table
 2. Press the handle (2) together and adjust the folding table according to the scale (1).
 3. Release the handle.
- ↵ The angle is set.
4. Pull out the folding table.

Setting the length

Maximum **dart length** 150 mm.

The seam length is regulated by programming it in the main menu or by the light barrier.

The variant to be used, light barrier or set value, can be selected in the main menu (📖 p. 31).

With transparent sewing material it is recommended to regulate the seam length by programming.

EXAMPLE: Template set, straight darts

Fig. 16: Template set, straight darts

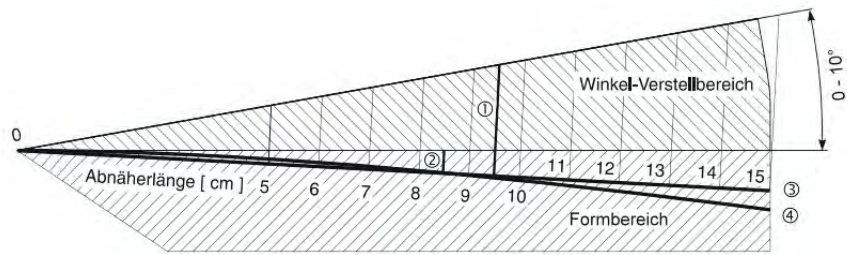

- (1) - Dart depth max. 2.1 cm at 10°, length 9.5 cm
- (2) - Dart depth max. 0.4 cm at 0°, length 8.5 cm
- (3) - Template set, straight darts
- (4) - Template set, curved darts

EXAMPLE: Template set pleats

Fig. 17: Template set pleats

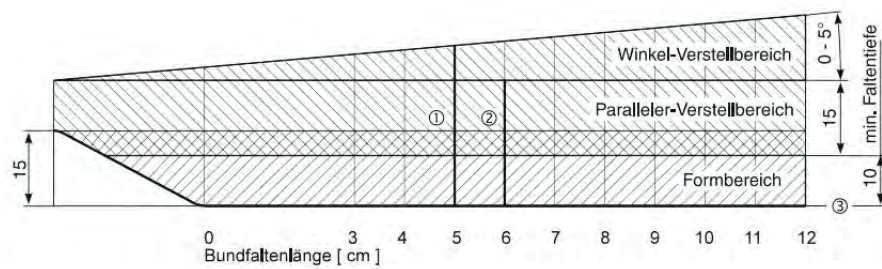

- (1) - Pleat depth max. 3.2 cm at 5°, length 5 cm
- (2) - Pleat depth max. 2.5 cm at 0°, length 6 cm
- (3) - Template set for pleats

4.14 Setting the insertion depth of the folding table

The first needle entry in the material should be as close as possible to the fold edge.

In order to achieve an evenly slim dart point with material of varied thickness, the machine is equipped with a fine adjustment.

Up to 7 different insertion depths can be set by using the stops (4).

Fig. 18: Setting the insertion depth of the folding table

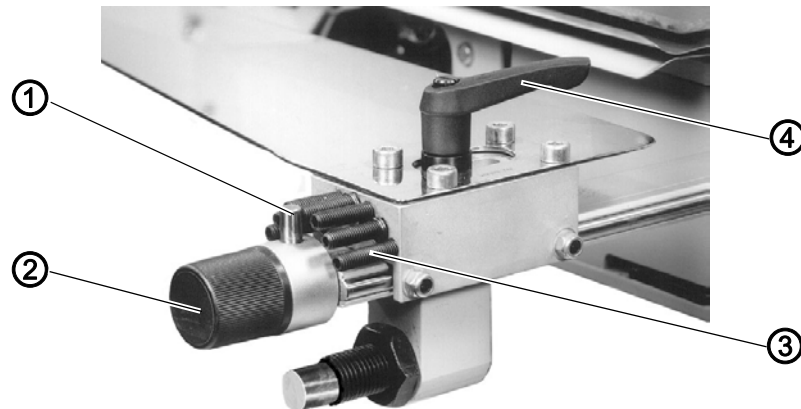

(1) - Stop
(2) - Adjustment knob

(3) - Set screw
(4) - Lever

Setting the insertion depth



To set the insertion depth:

1. Release the lever (4).
2. Slide the folding table on its guiding a little to the front.
3. Set one of the set screws (3) (7 pieces) to the desired insertion depth.
4. Turn the adjustment knob (2) to the desired insertion depth (until it stops).
5. Slide the folding table back to the rear.
The adjustment knob (3) has to abut on the stop (1).
6. Tighten the lever (4) again.

Altering the insertion depth



To alter the insertion depth:

1. Release the lever (4).
2. Slide the folding table on its guiding a little to the front.
3. Turn the adjustment knob (2) to the desired insertion depth (until it stops).
4. Slide the folding table back to the rear.
The adjustment knob (3) has to abut on the stop (1).
5. Tighten the lever (4) again.

4.15 Sewing

In order to start sewing, certain requirements have to be fulfilled. Below you will find the description of a typical sewing process.

Before sewing start, all dart lengths have to be marked on the folding plate (1) with adhesive tape (flat and as thin as possible).

Fig. 19: Sewing



(1) - Folding plate



To sew:

1. Turn on the machine at the main switch.
2. Start the reference run by pressing the "OK" key.
- ↳ The machine is ready for operation after carrying out a reference run. It is in its initial position.
3. Select a program in the main menu ( p. 31).
- ↳ The selected program is activated.
4. Put the workpiece with both hands around the edge of the folding plate.
5. Align the cut edges with the right hand to come on top of each other.
6. Adjust the notch for the dart length exactly at the rear edge of the folding plate.
7. Fix the workpiece by holding it with the right hand and slide in the folding plate.
- ↳ The workpiece is kept in place by the template set.
The folding plate slides back.
The sewing process is carried out.









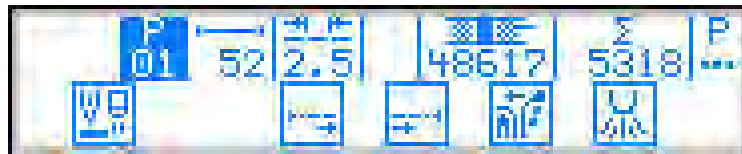

5 Programming

5.1 Main Menu

At this point, only the settings from the main menu necessary for sewing are listed.

Fig. 20: Main menu



Symbol	Explanation
	Program selection You can select between 20 programs with the up and down arrow keys (▲, ▼).
	Seam length in mm Value range: 19-150 The length of the seam can be adjusted to the millimetre.
	Stitch length in mm Value range: 1,0-4,0 The length of the stitches can be adjusted to the millimetre.
	Hook thread counter It indicates how many stitches can still be sewn with the bobbin (at intervals of 10). Reset by pressing and holding the OK button.
	Piece counter It shows the number of sewn parts. Reset by pressing and holding the OK button.
	Submenu This button takes you to the submenu.
	Light barrier The light barrier can be selected or deselected with key 1 .
	Seam beginning Use key 3 to select whether a condensed stitch or a backtack is to be sewn at the beginning of the seam.
	Seam end Use key 4 to select whether a condensed stitch or a backtack is to be sewn at the seam end.
	Smoother The smoother can be selected or deselected with key 5 .
	Blow-out device The blow-out device can be selected or deselected with key 6 .

5.2 Submenu

Submenu structure		
Symbol	Menu item	Settings
	Speed	
	Soft Start	Activated, Stitches, Speed
	Advance	Length, Speed
	Seam Begin	Lock type, Stitches, Speed, Stitchlength
	Seam Between	Lock type, Stitches, Speed, Stitchlength, Start at
	Seam End	Lock type, Stitches, Speed, Stitchlength
	Thread Chain	Length, Speed
	Stacker	TimeTillStart, TimeTillStop

5.2.1 Navigating in the submenu

Fig. 21: Navigating in the submenu

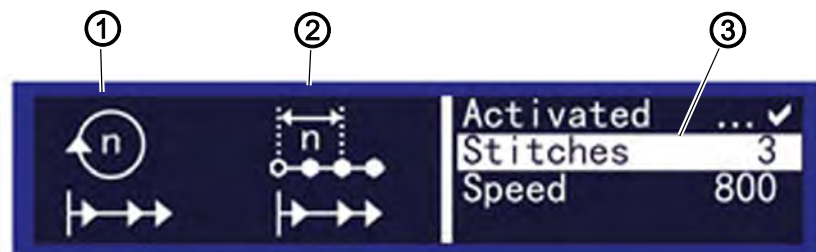

(1) - Symbol for the menu item
(2) - Symbol for the setting

(3) - Selected entry: highlighted

Selecting the menu item



To select the menu item:

1. Select the desired menu item by using the arrow keys (▼, ▲).
↪ The menu item is highlighted.
2. Activate the menu item with the **OK** key.
↪ The symbol for the menu item (1) appears on the left side of the display.
On the right side the settings of the menu item are listed.

Selecting the setting



To select the setting:

1. Select the desired setting by using the arrow keys (▼,▲).
↪ The setting is highlighted (3).
2. Activate the setting with the **OK** key.
↪ In addition to the symbol for the menu item (1), the symbol for the setting (2) appears on the left side of the display.

Changing the value



To change the value:

1. Change the value for the setting by using the numerical keys or the arrow keys (▼,▲).
2. Confirm the desired value with the **OK** key.
↪ The value is applied and memorized for the particular program.

Return to the submenu





To return to the submenu:





1. Use the arrow key ◀ to return to the previous level in the submenu.
2. Use the escape key to return to the main menu.







5.2.2 Settings in the submenu





	Menu item Speed Number of revs for the sewing speed	
Symbol	Explanation	Range of values
	There are no further settings for this menu item. Directly enter the value for the speed.	500 – 4000



	Menu item Soft start Settings for the soft start at seam beginning		
Symbol	Setting	Explanation	Range of values
	Activated	Switch the soft start on or off with the “OK” key. • On: display shows “✓” • Off: blank display	On/Off
	Stitches	Number of stitches for the soft start	1 – 9
	Speed	Number of revs for the sewing speed at soft start	500 – 2000



 Menu item Advance Settings for the advance at seam beginning			
Symbol	Setting	Explanation	Range of values
	Length	Length of the advance in mm	0 – 50
	Speed	Number of revs for the sewing speed at advance	500 – 4800

 Menu item Seam Begin Settings for tacks/stitch condensing at seam beginning			
Symbol	Setting	Explanation	Range of values
	Lock Type	Choose between tack and stitch condensing with the “OK” key: <ul style="list-style-type: none"> • Tack: display shows “✓” • Stitch condensing: blank display 	Tack/stitch condensing
	Stitches	Number of stitches with tack/stitch condensing	1 – 9
	Speed	Number of revs for the sewing speed when sewing the tack/stitch condensing	500 – 3000
	Stitchlength	Stitch length of the stitch condensing in mm	0.5 – 2.0

 Menu item Seam Between Settings for tacks/stitch condensing at seam midsection			
Symbol	Setting	Explanation	Range of values
	Lock Type	Choose between tack and stitch condensing with the “OK” key: <ul style="list-style-type: none"> • Tack: display shows “✓” • Stitch condensing: blank display 	Tack/stitch condensing
	Stitches	Number of stitches with tack/stitch condensing	1 – 9
	Speed	Number of revs for the sewing speed when sewing the tack/stitch condensing	500 – 3000
	Stitchlength	Stitch length of the stitch condensing in mm	0.5 – 2.0
	Start at	Indicates the seam segment in mm, after which the tack/stitch condensing will start.	10 – 130

 Menu item Seam End Settings for the tack/stitch condensing at seam end			
Symbol	Setting	Explanation	Range of values
	Lock Type	Choose between tack and stitch condensing with the "OK" key: • Tack: display shows "✓" • Stitch condensing: blank display	Tack/stitch condensing
	Stitches	Number of stitches with tack/stitch condensing	1 – 9
	Speed	Number of revs for the sewing speed when sewing the tack/stitch condensing	500 – 3000
	Stitchlength	Stitch length of the stitch condensing in mm	0.5 – 2.0

 Menu item Thread Chain Settings for a thread chain at seam end			
Symbol	Setting	Explanation	Range of values
	Length	Length of the thread chain in mm	8 – 25
	Speed	Number of revs for the sewing speed when sewing the thread chain	500 – 3000

 Menu item Stacker Settings for the stacker			
Symbol	Setting	Explanation	Range of values
	TimeTillStart	Time span in milliseconds after the seam end, before the smoother is activated.	10 – 1000
	TimeTillStop	Time span in milliseconds from the activation of the smoother until the shackle of the smoother moves upwards again.	10 – 1000

5.3 Installing the machine software

NOTICE

Property damage may occur!

The machine software is already installed when the machine is delivered.

Switch off the machine before connecting the dongle.

Loading a specific sewing software in the DAC classic control unit is possible with the help of the *Programmed Dongle*. The *Programmed Dongle* has a label indicating the machine class and the software version.

Such a loading (booting) may be used in order to provide a single DAC-classic control unit with a sewing software (first installation) or to install a newer machine software (update).

With the delivery of the machine only the test software (allowing the loading of sewing software) is installed in the control unit. The test software offers no further functions. If the test software gets damaged during the loading process, it is no longer possible to load a software using a dongle. In such a case use a PC with a loader cable.

The instructions for the DAC classic control unit is enclosed with the machine.

5.3.1 Loading the program

NOTICE

Property damage may occur!

Destroying of the software possible.

During the loading process do not remove the dongle and do not switch off the machine.

Fig. 22: Loading the program



(1) - Dongle

(2) - Plug-in position



To load the program:

1. Turn off the machine.
2. Insert the dongle (1) into the plug-in position (2) of the control unit.
3. Turn the main switch on.
- ↳ The Software will be loaded.
The loading process takes less than 60 seconds.
4. Turn off the main switch.
5. Remove the dongle (1).
6. Turn on the machine again.

5.3.2 Dongle-Update via Internet

NOTICE

Property damage may occur!

When transferring the machine software onto the dongle, it will first be deleted (formatted).

The programs (sequences, parameters) saved on the dongle will then be deleted. If still needed, please make a backup of the files into a computer (desktop, notebook).

The required software *Dongle Copy* is available in the *Download Area*.

Dongles can be updated by means of Internet. In order to do so, visit the Dürkopp Adler AG homepage www.duerkopp-adler.com. In the sections *Download Area > Software* you will find the auxiliary download software and the appropriate machine software. The instructions also available on the website, describe the complete update procedure of the dongle.

6 Maintenance

WARNING



Risk of injury from sharp parts!

Punctures and cutting possible.

Prior to any maintenance work, switch off the machine or set the machine to threading mode.

WARNING



Risk of injury from moving parts!

Crushing possible.

Prior to any maintenance work, switch off the machine or set the machine to threading mode.

This chapter describes maintenance work that needs to be carried out on a regular basis to extend the service life of the machine and achieve the desired seam quality.

Advanced maintenance work may only be carried out by qualified specialists ( *Service Instructions*).

Maintenance intervals

Work to be carried out	Operating hours			
	8	40	160	500
Cleaning the machine head	●			
Cleaning the motor fan sieve		●		
Lubricating the machine head	●			
Lubricating the hook	●			
Servicing the pneumatic system	●			

6.1 Swiveling up the machine head

For maintenance work the machine head can be swung up.

Abb. 23: Swiveling up the machine head



(1) - Positioning table
(2) - Template set

(3) - Handle



To swivel up the machine head:

1. Swivel the positioning table (1), the bundle clamp and the smoother aside.
2. Slide the template set (2) into the left end position.
3. Carefully swing up the machine head with the handle (3) and make it rest against the support.
- ↳ The machine's gravity center keeps it in position.
4. Swing back the machine in the same way.

6.2 Cleaning

WARNING



Risk of injury from flying particles!

Flying particles can enter the eyes, causing injury.

Wear safety goggles.

Hold the compressed air gun so that the particles do not fly close to people.

Make sure no particles fly into the oil pan.

NOTICE

Property damage from soiling!

Lint and thread remnants can impair the operation of the machine.

Clean the machine as described.

NOTICE

Property damage from solvent-based cleaners!

Solvent-based cleaners will damage paintwork.

Use only solvent-free substances for cleaning.

A clean machine protects against malfunctions.

6.2.1 Cleaning the machine head



To clean the machine head:

1. Remove dust and lint with a brush or compressed air gun.

6.2.2 Cleaning the motor fan sieve

Abb. 24: Cleaning the motor fan sieve

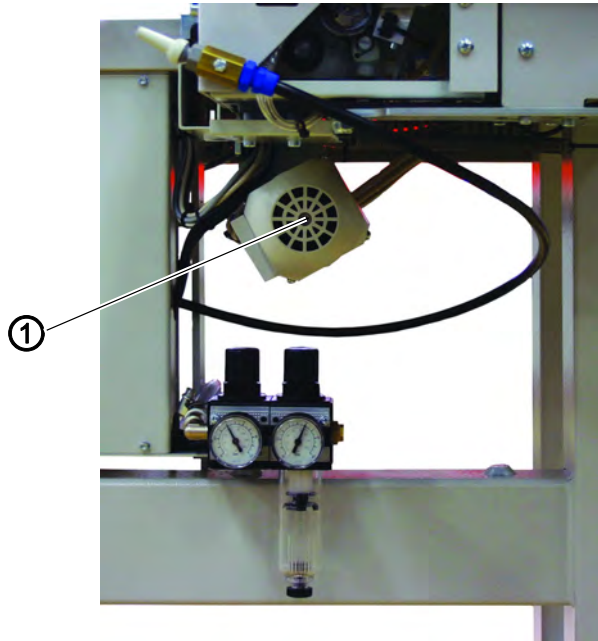

(1) - Motor fan sieve



To clean the motor fan sieve:

1. Remove dust with a brush or compressed air gun.

6.3 Lubricating

CAUTION



Risk of injury from contact with oil!

Oil can cause a rash if it comes into contact with skin.

Avoid skin contact with oil.
If oil has come into contact with your skin, wash the affected areas thoroughly.

NOTICE

Property damage from incorrect oil!

Incorrect oil types can result in damage to the machine.

Only use oil that complies with the data in the instructions.

CAUTION



Risk of environmental damage from oil!

Oil is a pollutant and must not enter the sewage system or the soil.

Carefully collect up used oil.
Dispose of used oil and oily machine parts in accordance with national regulations.

The machine is equipped with a central oil-wick lubrication system. The bearings are supplied from the oil reservoir.

For topping off the oil reservoir, use only lubricating oil **DA 10** or oil of equivalent quality with the following specifications:

- Viscosity at 40 °C: 10 mm²/s
- Flash point: 150 °C

You can order the lubricating oil from our sales offices using the following part numbers:

Container	Part no.
250 ml	9047 000011
1 l	9047 000012
2 l	9047 000013
5 l	9047 000014

6.3.1 Checking the machine head lubrication

Abb. 25: Checking the machine head lubrication

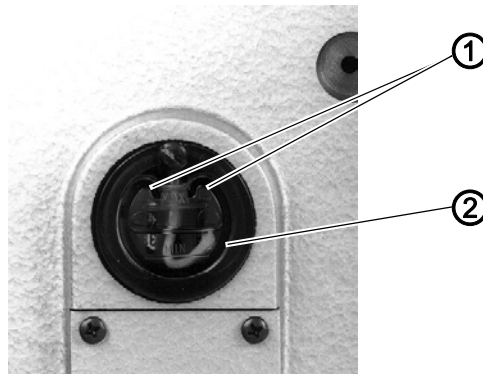

(1) - Drill-holes

(2) - Oil reservoir



To check the machine head lubrication:

1. The oil level in the oil reservoir (2) must not drop below the marking **MIN**.
2. If necessary, fill in oil through the drill-hole (1) in the inspection glass up to the marking **MAX**.

6.3.2 Checking the hook lubrication

Abb. 26: Checking the hook lubrication

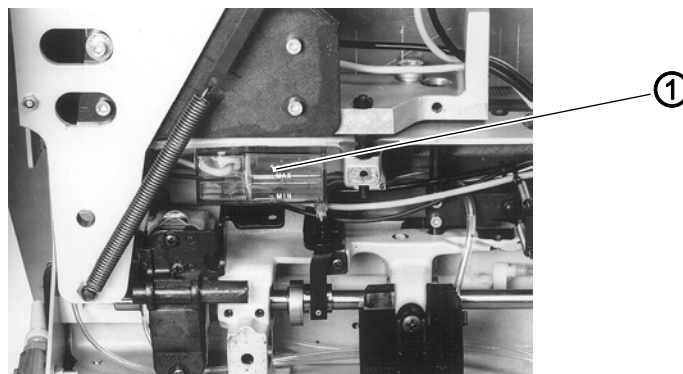

(1) - Oil reservoir



To check the hook lubrication:

1. Swivel up the machine head ( p. 40).
2. Fill up the oil reservoir (1) with oil up to the marking **MAX**.

The necessary oil quantity is factory set by the manufacturer. Increase or decrease the oil quantity only in exceptional circumstances.

6.4 Servicing the pneumatic system

6.4.1 Setting the operating pressure

NOTICE

Property damage from incorrect setting!

Incorrect operating pressure can result in damage to the machine.

Ensure that the machine is only used when the operating pressure is set correctly.



Proper setting

Refer to the **Technical data** (📖 p. 39) chapter for the permissible operating pressure. The operating pressure cannot deviate by more than ± 0.5 bar.

Check the operating pressure on a daily basis.

Abb. 27: Setting the operating pressure

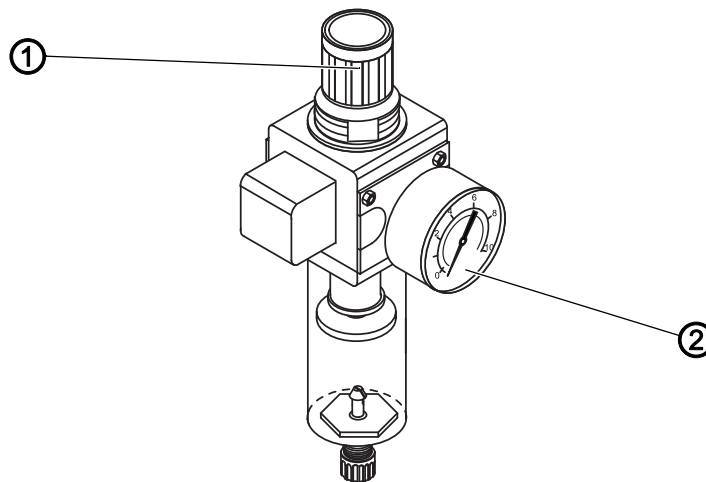

(1) - Pressure controller

(2) - Pressure gage



To set the operating pressure:

1. Pull the pressure controller (1) up.
2. Turn the pressure controller until the pressure gage (2) indicates the proper setting:
 - Increase pressure = turn clockwise
 - Reduce pressure = turn counterclockwise
3. Push the pressure controller (1) down.

6.4.2 Draining the water condensation

NOTICE

Property damage from excess water!

Excess water can cause damage to the machine.

Drain water as required.

Water condensation accumulates in the water separator (2) of the pressure controller.



Proper setting

Water condensation must not rise up to the level of the filter element (1).

Check the water level in the water separator (2) on a daily basis.

Abb. 28: Draining the water condensation

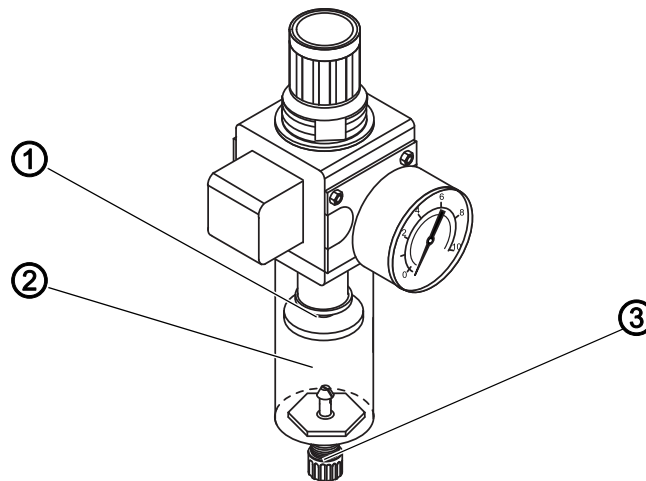

(1) - Filter element

(2) - Water separator

(3) - Drain screw



To drain water condensation:

1. Disconnect the machine from the compressed air supply.
2. Place the collection tray under the drain screw (3).
3. Loosen the drain screw (3) completely.
4. Allow water to drain into the collection tray.
5. Tighten the drain screw (3).
6. Connect the machine to the compressed air supply.

6.4.3 Cleaning the filter element

NOTICE

Damage to the paintwork from solvent-based cleaners!

Solvent-based cleaners damage the filter.

Use only solvent-free substances for washing out the filter tray.

Abb. 29: Cleaning the filter element

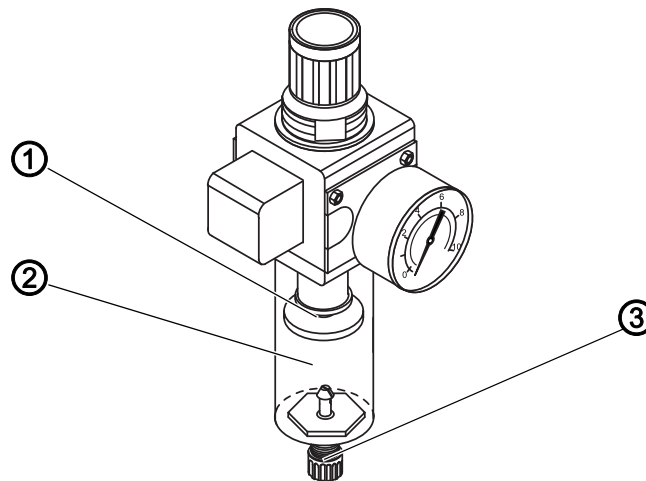

(1) - Filter element
(2) - Water separator

(3) - Drain screw



To clean the filter element:

1. Disconnect the machine from the compressed air supply.
2. Drain the water condensation ( p. 46).
3. Loosen the water separator (2).
4. Loosen the filter element (1).
5. Blow out the filter element (1) using the compressed air gun.
6. Wash out the filter tray using benzine.
7. Tighten the filter element (1).
8. Tighten the water separator (2).
9. Tighten the drain screw (3).
10. Connect the machine to the compressed air supply.

6.5 Parts list

A parts list can be ordered from Dürkopp Adler. Or visit our website for further information at:

www.duerkopp-adler.com



7 Setup

WARNING



Risk of injury from cutting parts!

Cutting injuries may be sustained while unpacking and setting up the machine.

Only qualified specialists may set up the machine.
Wear safety gloves.

WARNING



Risk of injury from moving parts!

Crushing injuries may be sustained while unpacking and setting up the machine.

Only qualified specialists may set up the machine.
Wear safety shoes.

7.1 Checking the scope of delivery

The scope of delivery depends on your specific order. Check that the scope of delivery is correct after taking delivery.

7.2 Removing the transport locks

Remove all transport locks before setting up the machine.

All moving parts must be unlocked:

- Standard equipment
- Optional equipment
- Small parts in the accessories

If the sewing unit is to be transported further, you must remove the transport securing devices.

7.3 Installing the machine

7.3.1 Transport

WARNING



Risk of injury due to incorrect transport!

Crushing possible.

DO NOT lift the machine by the table top.
ALWAYS use a lift truck or stacker.

WARNING



Risk of injury due to unstable standing!

Crushing possible.

Before putting the machine into operation, the frame feet must be unscrewed until a safe stand is achieved.

7.3.2 Lifting the machine



Important

Lift the frame without rollers ONLY with a lift truck or forklift.

7.3.3 Rolling the machine



Information

The frame is equipped with four castors for internal transport.

Fig. 30: Rolling the machine

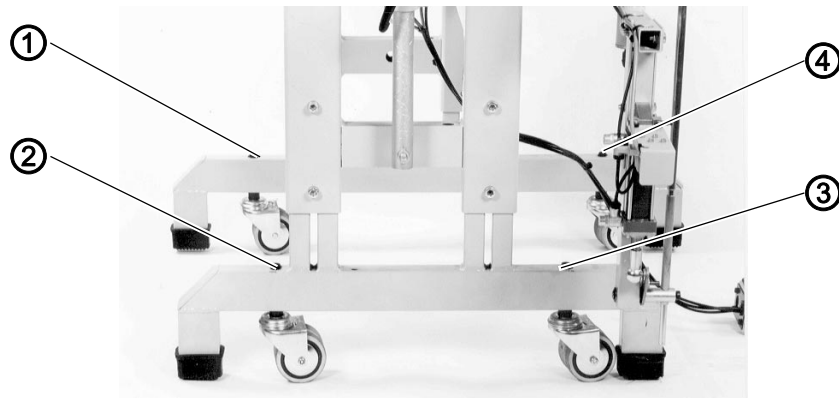

(1) - Adjusting screw
(2) - Adjusting screw

(3) - Adjusting screw
(4) - Adjusting screw



To roll the machine:

1. In order to transport the machine on its castors, turn the setting screws (1) to (4) counter-clockwise. The feet must have sufficient ground clearance for transportation.
2. Transporting the machine.
3. To lower the machine turn the setting screws (1) to (4) in clockwise direction.
The feet must stand firmly on the ground.

7.4 Setting the working height

WARNING



Risk of injury from moving parts!

The tabletop can sink under its own weight when the screws on the stand bars are loosened. Crushing possible.

Ensure that your hands are not jammed when loosening the screws.

CAUTION



Risk of musculoskeletal damage from incorrect setting!

The operator can sustain musculoskeletal damage if failing to comply with the ergonomic requirements.

Adjust the working height to the body height of the person who will operate the machine.

Fig. 31: Setting the working height

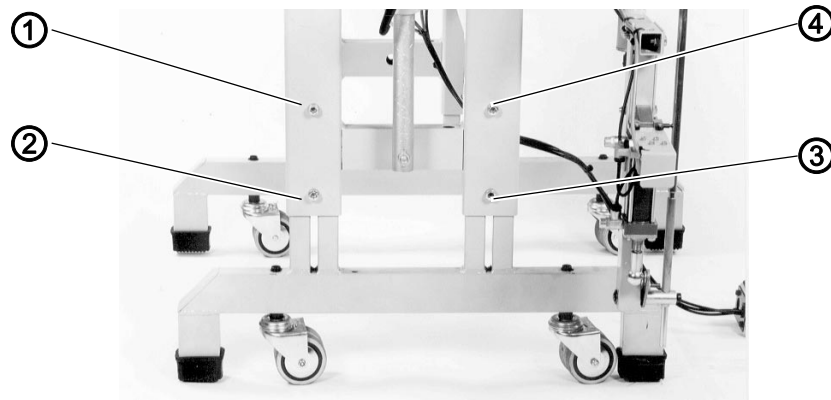

(1) - Screw
(2) - Screw

(3) - Screw
(4) - Screw

The working height is adjustable between 850 and 1250 mm (measured to the upper edge of the table plate).



To set the working height:

1. Loosen screws (1) to (4).
2. Set the machine to the desired height and level it out.
3. Re-tighten screws (1) to (4).

7.5 Assembling the thread reel holder

The thread reel holder is loosely added for shipment. In order to connect the machine to the power supply from the top, the connection cable can be run through the tube (2) of the thread reel holder.

Guide the compressed air supply pipe upwards through the second bore hole in the table top and then attach it to the thread reel holder with cable ties.

Fig. 32: Assembling the thread reel holder

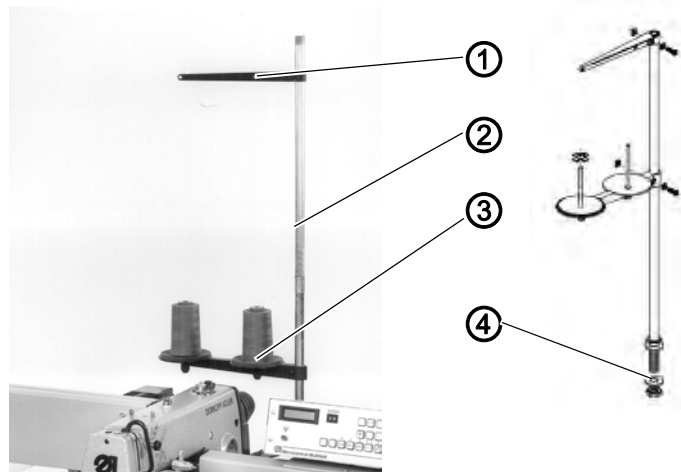

(1) - Unwinding bracket
(2) - Thread reel holder

(3) - Reel plate
(4) - Nut



To assemble the thread reel holder:

1. Insert the thread reel holder (2) into the bore hole of the table top.
2. Fix it with nut (4) underneath the table top.
3. Align the reel plate (3) and the unwinding brackets (1) parallel to the rear table edge. Reel plate (3) and the unwinding brackets (1) have to point into the same direction.

7.6 Assembling the holding device for the template set

Fig. 33: Assembling the holding device for the template set

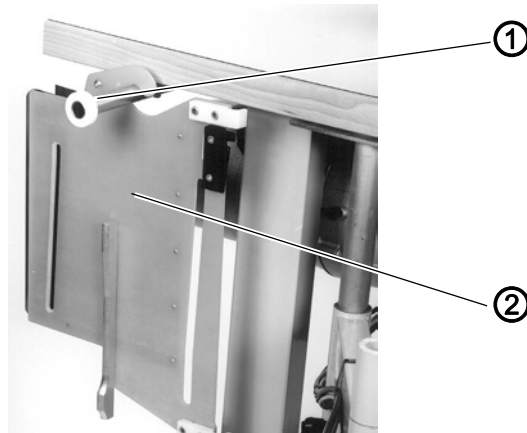

(1) - Holding device

(2) - Template set

During the transport the holding device (1) for the template set (2) is underneath the table top.



To assemble the holding device for the template set:

1. Remove the fastening screws.
2. Rotate the holding (1) device by 180°.
3. Re-attach the fastening screws.

7.7 Assembling the operating panel OP3000

Fig. 34: Assembling the operating panel OP3000

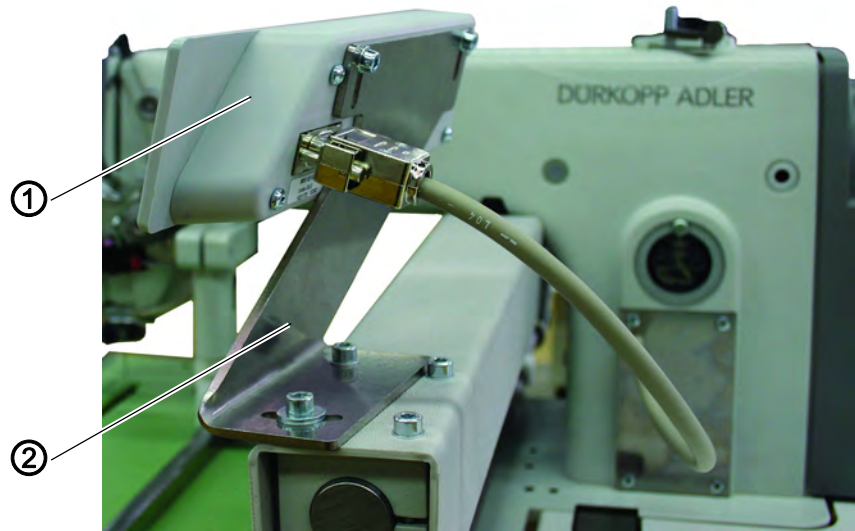

(1) - Control panel

(2) - Angle



To assemble the operating panel OP3000:

1. Attach angle (2).
2. Attach the operating panel (1) onto angle (2).

7.8 Electrical connection

DANGER



Risk of injury due to electric power!

Unprotected contact with electric power can cause dangerous injuries to life and limb..

All work on the electrical equipment may **ONLY** be carried out by qualified electricians or other appropriately trained persons.

ALWAYS disconnect the power plug before carrying out work at the electrical equipment.

Connecting the operating panel OP3000

Fig. 35: Connecting the operating panel OP3000

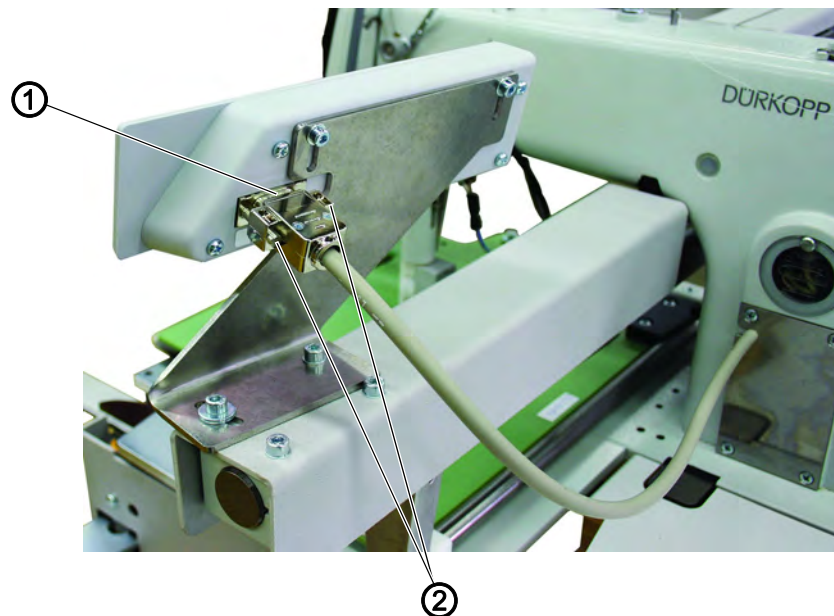

(1) - Plug

(2) - Screws



To connect the operating panel OP3000:

1. Insert plug (1).
2. Tighten screws (2).

7.9 Pneumatic connection

NOTICE

Property damage from oily compressed air!

Oil particles in the compressed air can cause malfunctions of the machine and soil the sewing material.

Ensure that no oil particles enter the compressed air supply.

NOTICE

Property damage from incorrect setting!

Incorrect system pressure can result in damage to the machine.

Ensure that the machine is only used when the system pressure is set correctly.

The pneumatic system of the machine and of the additional equipment must be supplied with dry and oil-free compressed air. The supply pressure must lie between 8 and 10 bar.

7.9.1 Assembling the compressed air maintenance unit



To assemble the compressed air maintenance unit:

1. Connect the connection hose to the compressed air supply using a hose coupling R 1/4".

7.9.2 Setting the operating pressure

NOTICE

Property damage from incorrect operating pressure!

Incorrect operating pressure can result in damage to the machine.

Ensure that the machine is only used when the operating pressure is set correctly.



Proper setting

Refer to the **Technical data** (📖 p. 39) chapter for the permissible operating pressure. The operating pressure cannot deviate by more than ± 0.5 bar.

Fig. 36: Setting the operating pressure

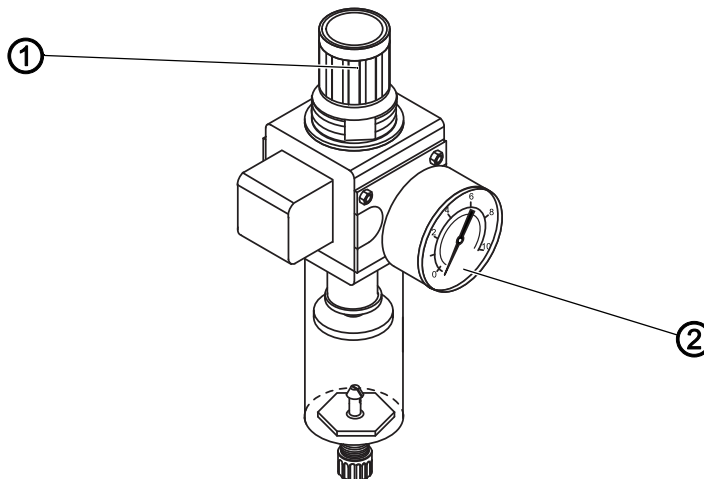

(1) - Pressure controller

(2) - Pressure gage



To set the operating pressure:

1. Pull the pressure controller (1) up.
2. Turn the pressure controller until the pressure gage (2) indicates the proper setting:
 - Increase pressure = turn clockwise
 - Reduce pressure = turn counterclockwise
3. Push the pressure controller (1) down.

7.10 Performing a test run

When setup is complete, perform a test run to check the functionality of the machine.

8 Decommissioning

WARNING



Risk of injury from a lack of care!

Serious injuries may occur.

ONLY clean the machine when it is switched off.
Allow ONLY trained personnel to disconnect the machine.

CAUTION



Risk of injury from contact with oil!

Oil can cause a rash if it comes into contact with skin.

Avoid skin contact with oil.
If oil has come into contact with your skin, wash the affected areas thoroughly.



To decommission the machine:

1. Switch off the machine
2. Unplug the power plug.
3. If applicable, disconnect the machine from the compressed air supply.
4. Remove residual oil from the oil pan using a cloth.
5. Cover the control panel to protect it from soiling.
6. Cover the control to protect it from soiling.
7. Cover the entire machine if possible to protect it from contamination and damage.

9 Disposal

CAUTION



Risk of environmental damage from improper disposal!

Improper disposal of the machine can result in serious environmental damage.

ALWAYS comply with the national regulations regarding disposal.

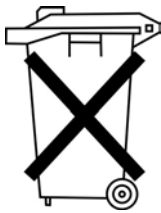

The machine must not be disposed of in the normal household waste.

The machine must be disposed of in a suitable manner in accordance with all applicable national regulations.

When disposing of the machine, be aware that it consists of a range of different materials (steel, plastic, electronic components, etc.). Follow the national regulations when disposing these materials.

10 Troubleshooting

10.1 Customer Service

Contact for repairs and issues with the machine:

Dürkopp Adler AG

Potsdamer Str. 190
33719 Bielefeld, Germany

Tel. +49 (0) 180 5 383 756
Fax +49 (0) 521 925 2594
Email: service@duerkopp-adler.com
Internet: www.duerkopp-adler.com



10.2 Messages of the software

Please contact customer service if an error occurs that is not described here. Do not attempt to correct the error yourself.

Code	Meaning	Troubleshooting
3210	Needle thread rupture	Thread in a new needle thread, p. 16.
3215	Hook thread counter has reached value 0	Check the bobbin's thread reserve and insert a new bobbin if necessary, p. 18 reset the hook thread counter, p. 31
3216	Residual thread monitor reports empty bobbin	Insert a new bobbin, p. 18.
3302	No pressure available	Check the pressure at the maintenance unit, p. 45.
3303	Folding table in wrong position	Pull out the folding table.
3304	No template set inserted	Insert a template set. Check the contact pressure, if a template set is already inserted.
3340	Contact pressure too low	Correct the contact pressure for the template set by setting the screw at the top on the hold-down cylinder.

10.3 Errors in sewing process

Error	Possible causes	Remedial action
Unthreading at seam beginning	Needle thread tension is too firm	Check needle thread tension
Thread breaking	Needle thread and hook thread have not been threaded correctly	Check threading path
	Needle is bent or sharp-edged	Replace the needle
	Needle is not inserted correctly into the needle bar	Insert the needle correctly into the needle bar
	The thread used is unsuitable	Use recommended thread
	Thread tensions are too tight for the thread used	Check thread tensions
	Thread-guiding parts, such as thread tube, thread guide or thread take-up disk, are sharp-edged	Check threading path
	Throat plate, hook or spread have been damaged by the needle	Have parts reworked by qualified specialists
Missing stitches	Needle thread and hook thread have not been threaded correctly	Check threading path
	Needle is blunt or bent	Replace the needle
	Needle is not inserted correctly into the needle bar	Insert the needle correctly into the needle bar
	The needle thickness used is unsuitable	Use recommended needle thickness
	The reel stand is installed incorrectly	Check the assembly of the reel stand
	Thread tensions are too tight	Check thread tensions
	Throat plate, hook or spread have been damaged by the needle	Have parts reworked by qualified specialists

Error	Possible causes	Remedial action
Loose stitches	Thread tensions are not adjusted to the sewing material, the sewing material thickness or the thread used	Check thread tensions
	Needle thread and hook thread have not been threaded correctly	Check threading path
Needle breakage	Needle thickness is unsuitable for the sewing material or the thread	Use recommended needle thickness

11 Technical data

Noise emission

Workplace-specific emission value as per DIN EN ISO 10821:

$$L_{pA} = 79,2 \text{ dB (A)}; K_{pA} = 0,64 \text{ dB (A)}$$

Data and characteristic values

Technical data	Unit	Class
Machine type		301/ Double lockstitch
Hook type		Horizontal hook small/large
Number of needles		1
Needle system		134/7
Needle strength	[Nm]	90
Stitch length	[mm]	1,9; 2,2; 2,5; 2,8
Speed maximum	[min ⁻¹]	4800
Speed on delivery	[min ⁻¹]	4500
Mains voltage	[V]	230
Mains frequency	[Hz]	50/60
Operating pressure	[bar]	6
Length	[mm]	2300
Width	[mm]	1200
Height	[mm]	1350
Weight	[kg]	180

Characteristics

- Sewing length controlled alternatively by light barrier or by programming
- Seam protection alternatively at seam beginning and seam end through stitch condensing or bartacking the material and thread chain
- Thread trimming system: Controlled chain trimmer
- High sewing performance and short cycle duration due to DAC classic in combination with a stepping motor and an additional control unit for the material feed
- Fully overlapping working method
- Compact, height adjustable sewing unit with transport castors, to be operated in standing or sitting position
- Positioning station, folder station and sewing station are combined in a single swivel-mounted unit for easy maintenance and setting access
- Electronic thread monitoring system
- Designed to process spun and monofilament threads
- Integrated setting disc with positioning marks on the hand-wheel for a rapid and precise control of the machine settings
- A template set adapted to the sewing shape retains and guides the workpiece
- The template can be easily exchanged; upon ordering the sewing unit, one or several template sets have to be selected.
- The dart depth depends on its length, the template set and the setting of the folding table; by adjusting the folding table between 0 and 10°, the dart depth can be altered

12 Appendix

Wiring diagram

Fig. 37: Wiring diagram

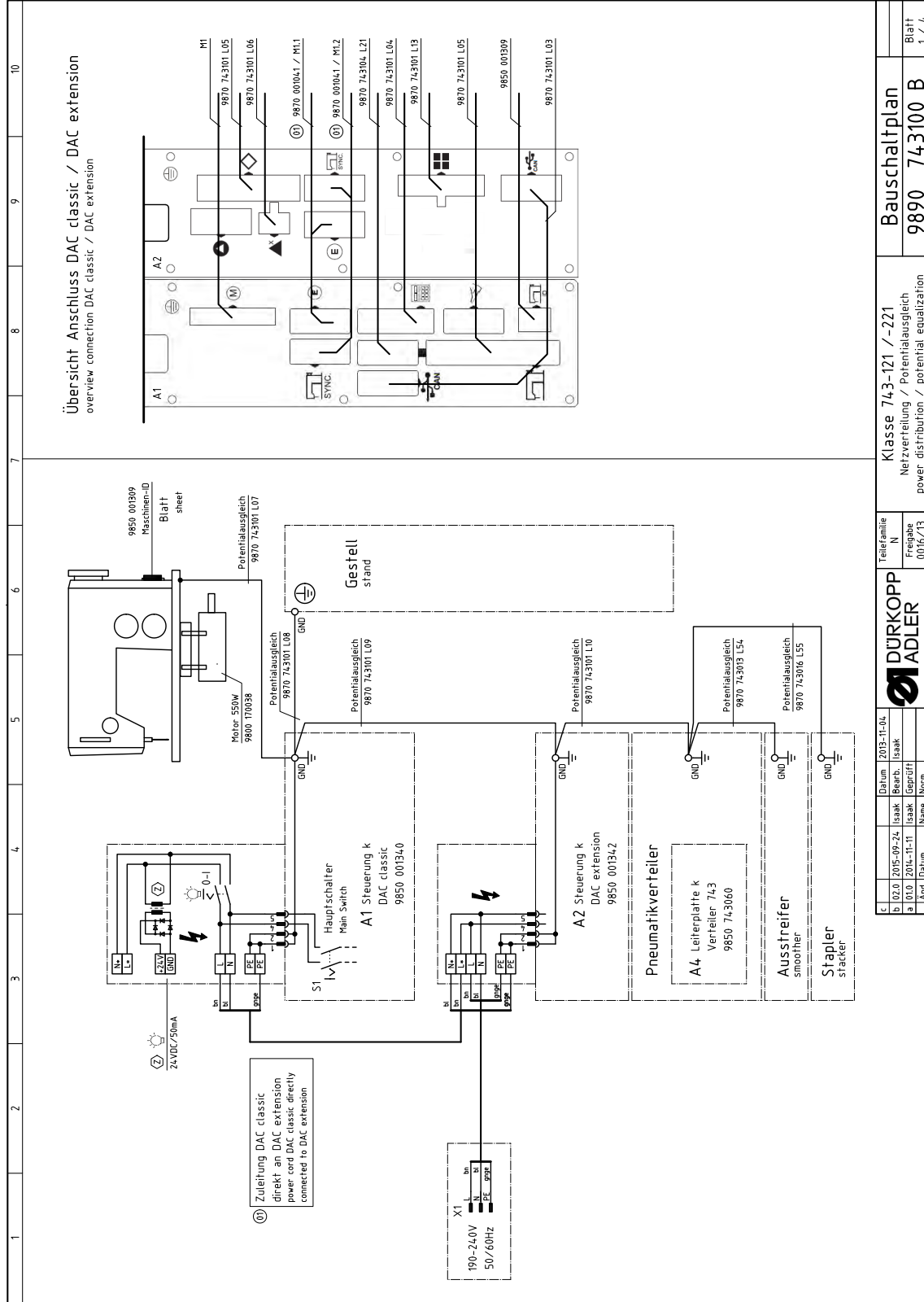

DURKOPP ADLER Teilfamilie N Freigabe 0016/13		Bauschaltplan 9890 743100 B	
Klasse 743-121 / -221 Netzverteilung / Potentialausgleich power distribution / potential equalization			
c 1020 2015-09-24 Isaaq Reib. Isaaq b 010 2014-11-11 Isaaq Geniff a 010 Datum Name Norm	Datum 2013-11-04 Reib. Isaaq		
Blatt 1 / 4			

Fig. 38: Wiring diagram

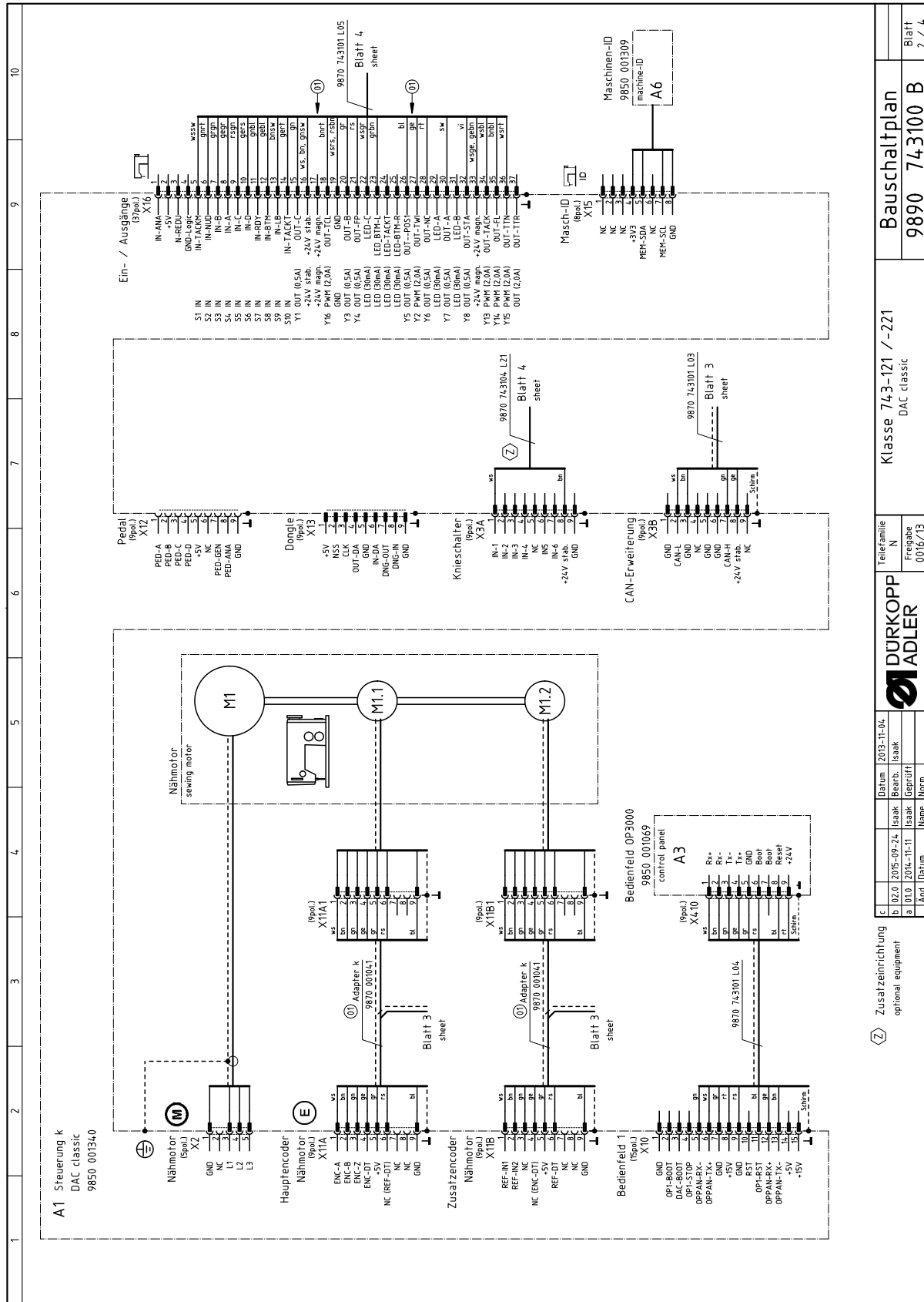

Zusatzzeichnung optional equipment		DURKOPP ADLER		Klasse 743-121 / -221 DAC classic		Bauschaltplan 9890 743100 B		Blatt 2 / 4	
Teilfamilie Freigabe 0016/13		Datum: 2013-11-04 Bearb.: Isak		Datum: 2013-11-04 Bearb.: Isak		Dateiname: 2013-11-04 Isak		Dateiname: 2013-11-04 Isak	
Änd. / Datum		Name / Norm		Name / Norm		Name / Norm		Name / Norm	
a 01.0 2014-11-11		Isak		Isak		Isak		Isak	
b 02.0 2015-09-24		Isak		Isak		Isak		Isak	

Fig. 39: Wiring diagram

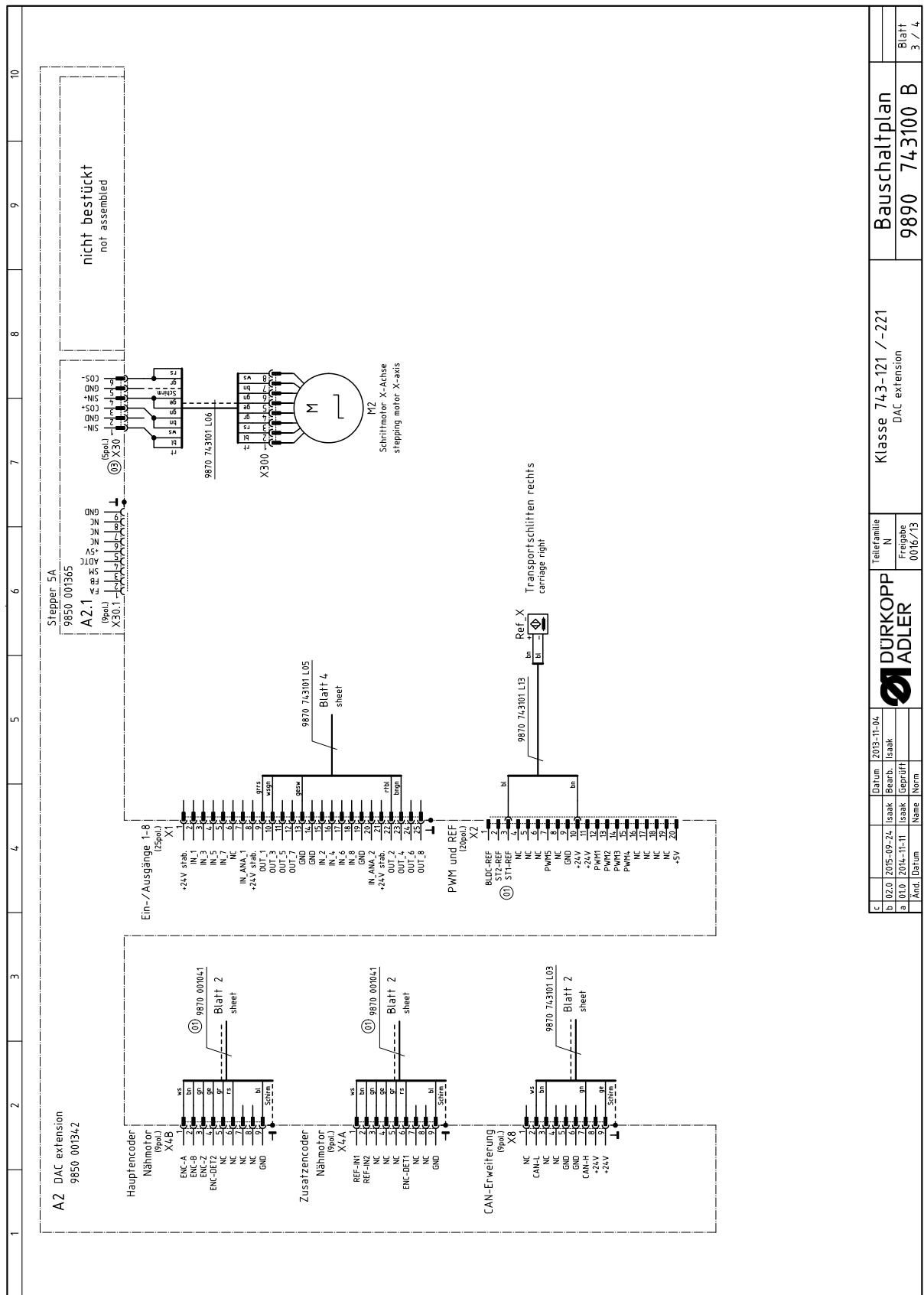

Klasse 743-121 / -221 DAC extension		Bauschaltplan 9890 743100 B	
Teilfamilie N Freigabe 0016/13		Datum 2013-11-04 Bearb. Isaak	
DURKOPP ADLER		Name Norm	
a 01.0 2014-11-11		Isaak Geprüff	
b 02.0 2015-09-24		Isaak	
c 01.0 2016-11-11		Isaak	
Änd. Datum		Name Norm	
		Blatt 3 / 4	



DÜRKOPP ADLER AG
Potsdamer Str. 190
33719 Bielefeld
Germany
Phone: +49 (0) 521 925 00
E-Mail: service@duerkopp-adler.com
www.duerkopp-adler.com