

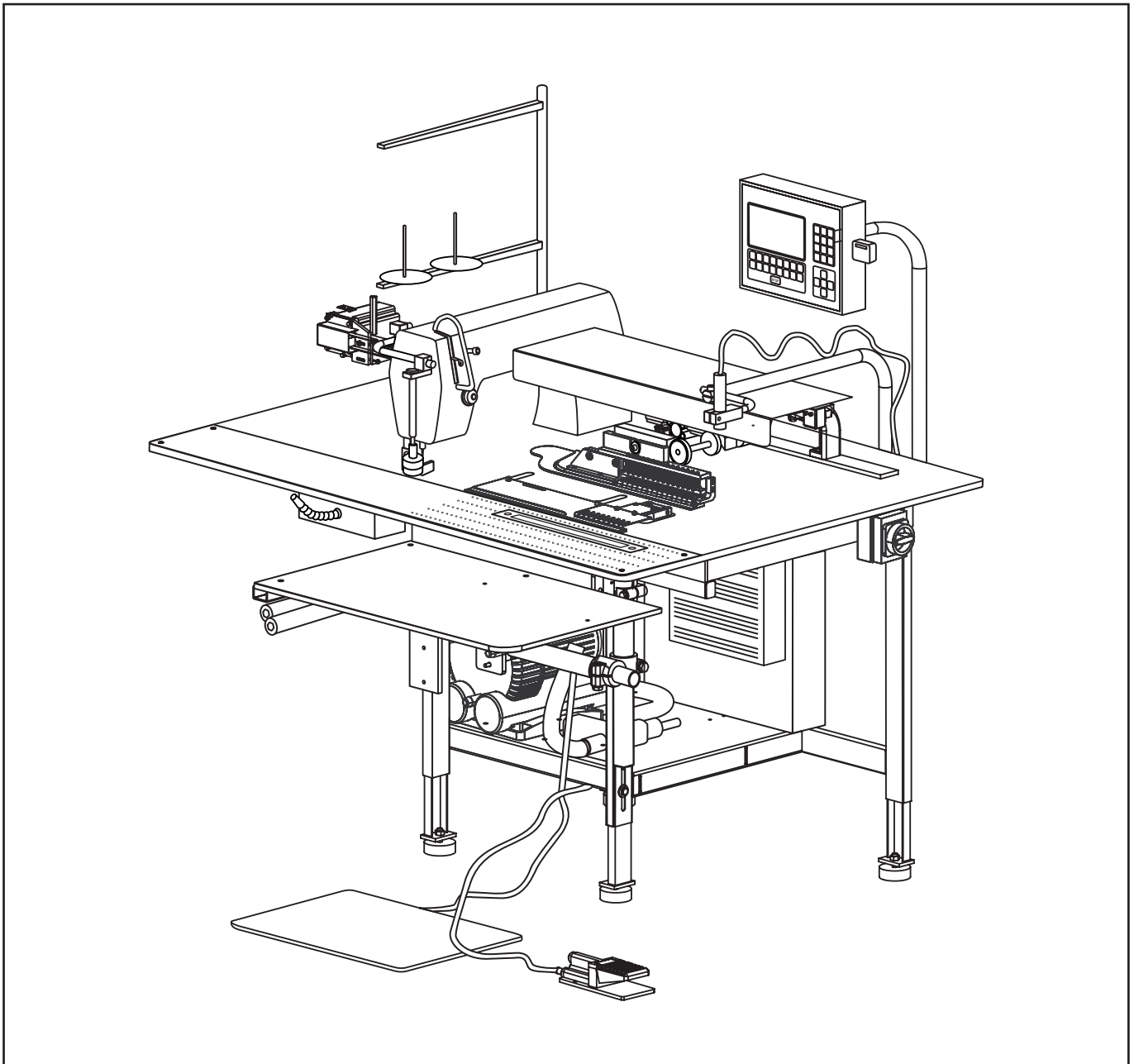

# Working Instructions

## Short Seam Automat 1931-5



## Contents of the working instructions

The working instructions are divided into four sections:

**A General notes: Page A 1 - A 10**

Safety instructions for the operating and service personnel and for the operator of the machine.

**B Operating instructions: Page B 11 - B 26**

Instructions for the personnel operating and handling the machine.

**C Service instructions: Page C 27 - C 57**

Instructions for the personnel in charge of the initial start-up, setting up and service of the machine.

**D Programming instructions: Page D 58 - D 88**

Instructions for the service personnel in charge of preparing and setting up the machine.

### Scope of the working instructions

These working instructions describe the SHORT SEAM AUTOMAT 1931-5 of Beisler GmbH and apply only to those machine parts and components that are contained in the scope of delivery of the SHORT SEAM AUTOMAT 1931-5.

They do not apply to accessories or machine parts (e.g. sewing head) from third parties that the machine is equipped or retrofitted with. For those components, the working instructions of the respective manufacturer or supplier apply.

# Section A

General notes

# Section A **General notes**

## Contents

<b>A.1 Safety instructions .....</b>	<b>5</b>
A.1.1 Symbols used in the working instructions .....	8
A.1.2 Symbols used on the machine .....	8
A.1.3 General safety instructions .....	9
<b>A.2 Notices .....</b>	<b>10</b>

# A.1 Safety instructions

## Important information for the operator!

This machine has been manufactured in keeping with the latest technological developments and is operationally safe. However, it may present potential hazards, particularly if it is operated by inadequately trained personnel or if it is not used correctly:

- For personnel operating and handling the machine, the operator must prepare written instructions in a reasonable form and in the language of the operating personnel based on these working instructions (Germany: Accident Prevention Regulations UVV VBG 1 § 7.2).
- Use the operating instructions to familiarize the operating personnel with the functions, operation, and care of the machine and check to see if the operating personnel fully understands these instructions.
- Use the service instructions to familiarize the service personnel with the setting up and maintenance of the machine.
- For any modifications of the machine that have not been approved by Beisler GmbH in writing, the operator is fully responsible.
- The contents of the working instructions are subject to change without further notice.
- Concerning translations into foreign languages, the German version of these working instructions is binding.
- Should you encounter problems that are not mentioned in these working instructions, please contact your supplier immediately for your own safety. Please do not hesitate to contact Beisler if you have any suggestions that help to improve this product.
- **Keep these working instructions close to the machine so that safety instructions and information on operation, setting-up, and maintenance are always accessible.**

## Warranty

Beisler GmbH warrants the safety, operability, and repair without charge of the short seam automat 1931-5 for a period of 6 months under the condition that:

- the machine is used exclusively for the intended purpose and serviced in accordance with the information in these working instructions,
- modifications of the machine are carried out only with prior written approval of Beisler GmbH,
- only original spare parts or accessories approved by Beisler GmbH are used. For a complete list of all approved spare parts, please contact Beisler GmbH.

If the machine is used for more than 10 hours per day (shift operation), the warranty period is reduced to 3 months.

The warranty period starts with the delivery of the machine to the operator.

# A.1

## Safety instructions

### Exclusion of liability

Beisler GmbH warrants the faultlessness of the product as set forth by their advertisements, product information and these working instructions. Other product characteristics are not warranted.

Beisler GmbH is not responsible for the profitability or for the correct function of the short seam automat 1931-5 if it is used for other purposes than those defined in section „Correct use“.

Beisler GmbH is not responsible for damage that arises from the use of non-defined and non-approved spare parts or accessories.

### Copyright

© 2005 Beisler GmbH, Hösbach; 07/2005

### Short seam automat

The short seam automat 1931-5 and all related parts are protected by copyright. Any reproduction of the machine will be prosecuted.

### Working instructions

These working instructions are protected by copyright. No part of the working instructions, including figures and tables, may be reproduced or translated in any form or by any means, electronic or mechanical, without the express written permission of Beisler GmbH.

**Beisler GmbH**  
**Fohnradstr. 10**  
**63768 Hösbach**  
**Germany**

**Phone: ++ 49 / 6021 / 50 19 0**  
**Fax: ++ 49 / 6021 / 50 19 10**

**eMail: [vertrieb@beisler-gmbh.de](mailto:vertrieb@beisler-gmbh.de)**

# A.1 Safety instructions

## **Important information for the operating personnel!**

Please note that any work to the SHORT SEAM AUTOMAT 1931-5 must be carried out only by trained operating personnel:

- **Operating personnel means persons:**
  - that have been given initial instructions for sewing automats and that have been trained for the operation and handling of the SHORT SEAM AUTOMAT 1931-5 on the basis of these operating instructions, that have been informed about potential risks arising from their work with the machine,
  - that are capable of assessing their work with the machine due to occupational experience and instruction of the safety regulations and of recognizing potential hazards during work.
- Cleaning of the machine or of machine parts must be performed only by personnel that has been informed about potential hazards arising during the cleaning work.
- Prior to the initial operation of the SHORT SEAM AUTOMAT 1931-5, read the **operating instructions** carefully so that you can make full use of the advantages of the machine and to prevent damage.

## **Important information for the service personnel!**

Please note that service work to the SHORT SEAM AUTOMAT 1931-5 must be carried out only by authorized and adequately trained expert personnel:

- **Expert personnel means persons:**
  - that have acquired their expertise by a special training in machine technology or electrical engineering or by a special advanced training or a comparable qualification,
  - that have acquired the knowledge required to perform all works for setting up and servicing the SHORT SEAM AUTOMAT 1931-5 from a training by Beisler GmbH,
  - that are capable of assessing their work with the machine due to occupational experience and instruction of the safety regulations and of recognizing potential hazards during work.
- Prior to carrying out any service work to the SHORT SEAM AUTOMAT 1931-5, read the **entire working instructions** carefully so that you can make full use of the advantages of the machine and to prevent damage.

# A.1 Safety instructions

## A.1.1 Symbols used in the working instructions

### **WARNING!**

is used if non-observance may cause serious or even lethal injuries.

### **CAUTION!**

is used if non-observance may cause medium to minor injuries or damage.

### **NOTE!**

is used for hints and useful information.

## A.1.2 Symbols used on the machine

### **WARNING: DANGER!**

Caution! Observe working instructions.

### **WARNING: HIGH VOLTAGE!**

Caution! Prior to opening, pull out power plug.



# A.1 Safety instructions

## A.1.3 General safety instructions

### Correct use

- The SHORT SEAM AUTOMAT 1931-5 is a sewing machine. It is to be used for stitching slash sel-vages.
- The machine can be used for processing all conventional materials for outerwear.
- The machine has been designed for permanent operation in industry.
- The SHORT SEAM AUTOMAT 1931-5 has been tested for electromagnetic compatibility and is suited for installation in industrial operating rooms.

### Incorrect use

- The SHORT SEAM AUTOMAT 1931-5 must not be operated in rooms that do not comply with the location requirements.
- The SHORT SEAM AUTOMAT 1931-5 must not be operated in the vicinity of devices or systems that produce strong magnetic fields as otherwise the correct function of the program control may be impaired.

### Safety requirements

- DIN EN, Part 1:1991-11, Part 2:1995-06  
Safety of machines
- DIN EN 60601, Part 1:1994-05  
Safety regulations for electrically operated measuring and control installations, general requirements.
- DIN EN 50178 (VDE 0160): 1998-04  
Equipment of power systems with electronic devices.
- DIN EN 50082 (VDE 0839) Part 2:1997-11  
Electromagnetic compatibility, basic specification, immunity to interference.  
Part 1: Domestic, business and commerce, small enterprises.  
Part 2: Industry.
- DIN EN 60204 (DIN VDE 0113): 1993-06  
Electrical equipment of industrial machines.

### Safety devices

The SHORT SEAM AUTOMAT 1931-5 is equipped with a circuit-breaker (**program stop switch**) that stops all machine movements and the sewing process when actuated manually.

### Power supply connection

The power supply of the machine is established with a properly grounded power supply connection with:

- 230 V  $\pm$  10 %, 50/60 Hz, grounding plug.
- Fusing: 16 A
- Power consumption: 1.3 kW

### Compressed air supply

The machine must be supplied by an on-site compressed air source.

- Operating pressure: 6 bar.
- Compressed air quality: oil-free
- Compressed air consumption: 16 NL

### Location and storage requirements

Installation in sheltered, closed rooms.

- Room temperature: +10 °C to 45 °C
- Relative humidity: 80 % max.

### Disposal

- Please discard the packaging material in accordance with existing disposal directives. Section C1, Delivery of the machine, contains a list of the packaging materials used.
- The machine contains reusable materials. Therefore, when discarding the machine, ask your local magistrate or community office about the possibilities of recycling.

# A.2

## Notices

# **Section B** **Operating Instructions**

# Section B

## Operating Instructions

### Contents

<b>B.1. Description of the machine</b> .....	<b>12</b>
B.1.1 Functional units .....	13
<b>B.2. Functions of the machine</b> .....	<b>14</b>
B.2.1 Functional sequence .....	14
B.2.2 Line-up and alignment .....	14
B.2.3 Transport and sewing .....	15
B.2.4 Switches .....	16
B.2.5 Operating panel .....	17
<b>B.3. Operation</b> .....	<b>18</b>
B.3.1 Safety instructions for operation .....	18
B.3.2 Preparing the machine .....	19
B.3.3 Selecting the sewing program .....	21
B.3.4 Activating additional seam numbers .....	22
B.3.5 Deactivating a seam number .....	22
B.3.6 Setting the thread clamp manually .....	22
B.3.7 Resetting the day counter to zero .....	22
B.3.8 Selecting the double seam function .....	23
B.3.9 Aligning sewing pieces .....	24
B.3.10 Starting machine cycle .....	25
B.3.11 Resetting line-up process .....	25
B.3.12 Stopping a sewing program.....	26
B.3.13 Moving machine to zero position .....	26
B.3.14 Turning the machine off .....	26
B.3.15 Periodic cleaning of the machine .....	26

# B.1 Description of the machine

## B.1.1 Functional units

Fig. 1

All functional units of the SHORT SEAM AUTOMAT 1931-5 are mounted to the height-adjustable table frame and freely accessible.

### Transport and sewing unit

- 1 Switching swivel stamp
- 2 Linear rail with drive motor
- 3 Thread holder
- 4 Sewing head
- 5 Guide laser
- 10 Main clamp
- 11 Cloth clamp
- 21 Stop rail

### Control unit

- 6 Operating panel
- 7 Memory stick

### Not-Schalter

- 8 Key Program STOP

### Worktable

- 14 Height-adjustable table leg
- 15 Working plate with slidepanel perforation for vacuum
- 19 Storage table
- 20 Bundle clamp

### Power supply system

- 9 Main switch, emergency off switch
- 12 Control box
- 13 Sewing motor control

### Compressed air / Vacuum supply system

- 18 Vacuum pump (optional)
- 22 Compressed air device

### Operating switches

- 16 Footswitch for bundle clamp
- 17 Footswitch for machine operation

Fig. 1

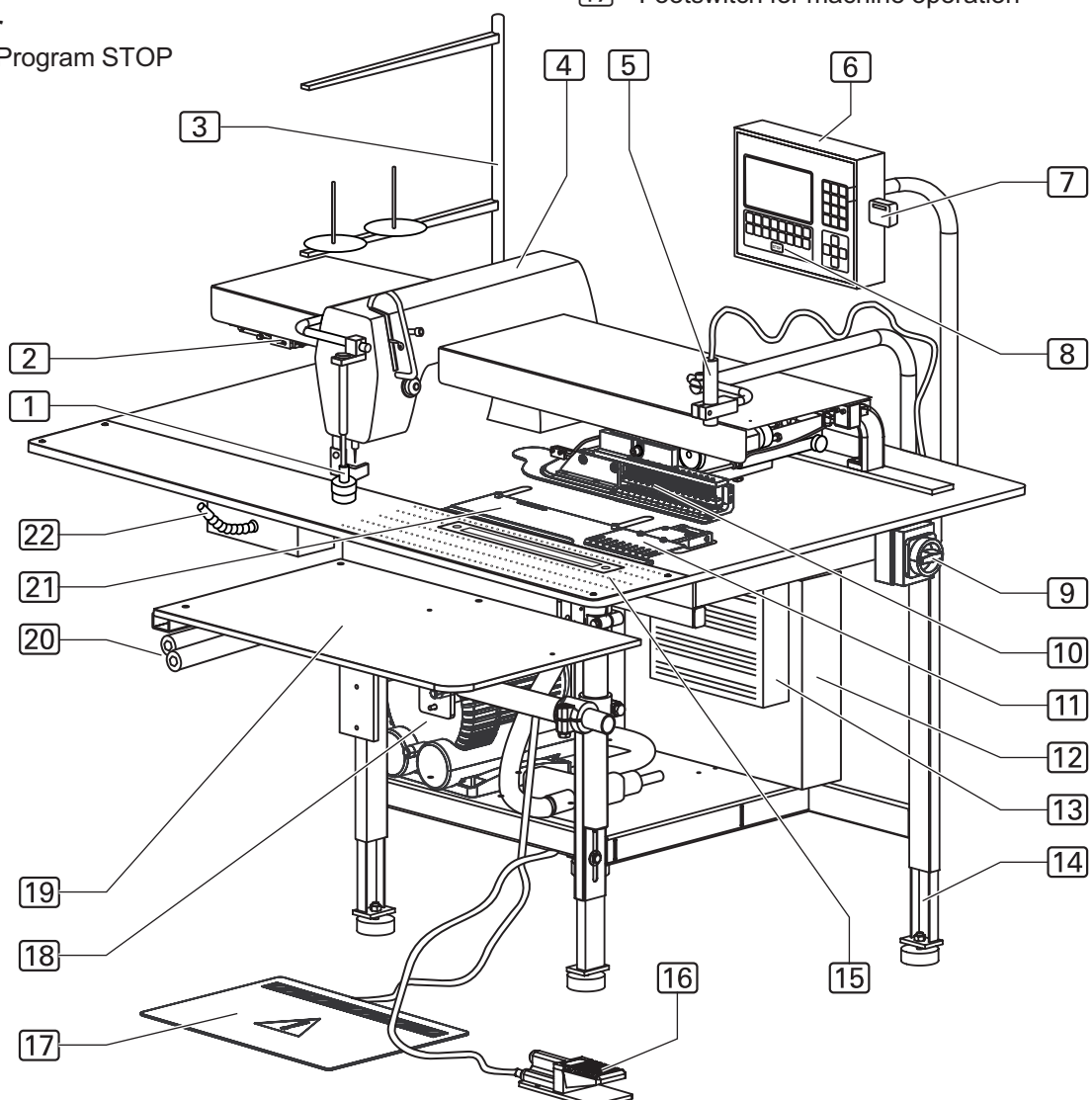

# B.2 Functions of the machine

## B.2.1 Functional sequence

The short seam automat allows the automated stitching of slash selvages. The sewing piece is positioned manually, attached to the working plate by vacuum and holding stamper and then automatically transferred by the transport system to the sewing head where it is tucked and ejected.

## B.2.2 Line-up and alignment

### Bundle clamp

The sewing pieces are clamped in bundles in the bundle clamp and held ready for the tucking process. The bundle clamp is operated with compressed air and controlled by a footswitch (see Fig. 1).

### Stop, Fig. 2:

The stop rail [2] is used to align the parallel course of the seam [6].

### Guide laser [1]

The guide laser is used to align the sewing piece to the correct end point of the seam. The guide laser creates a red marking line [5] which helps to line up the sewing piece [4] at the stop rail [2]. The cloth clamp [3] holds the waistband down.

### Stitch width handwheel, Fig. 3:

Use the handwheel [1] to set the required stitch width in relation to the stop rail of the worktable. This setting determines how far the main clamp [2] is moved beyond the stop rail where it picks up and transports the sewing piece to the sewing head. The handwheel offers four settings that have been adapted to the four factory-programmed sewing programs:

Stitch width 30 mm

Stitch width 32 mm

Stitch width 35 mm

Stitch width 37 mm

Fig. 2/3

Fig. 2

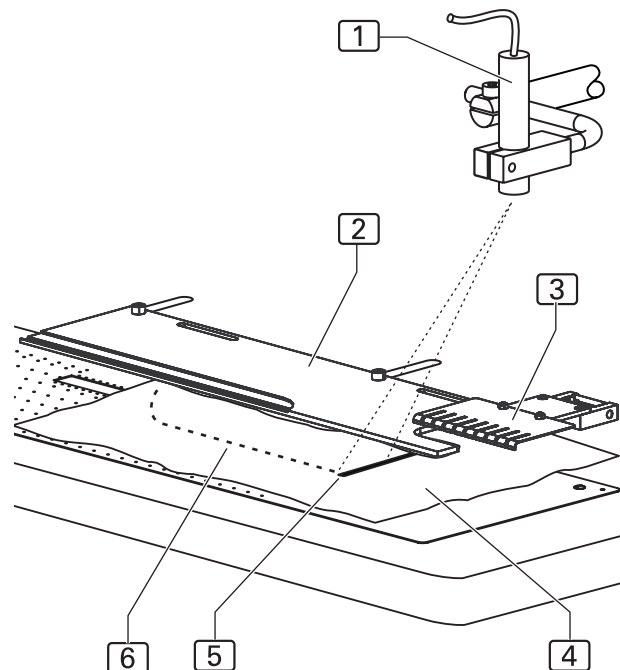
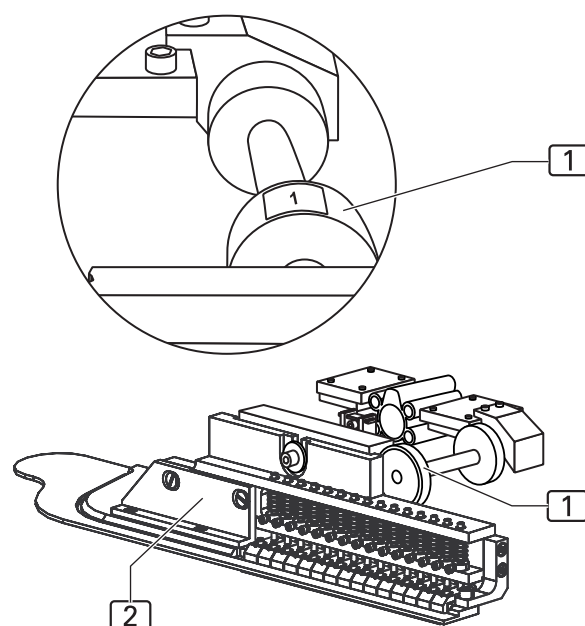

Fig. 3



# B.2 Functions of the machine

## B.2.3 Transport and sewing

Fig. 4

### Vacuum,

If the sewing piece **3** is aligned to the stop and the red marking line of the guide laser **6**, the vacuum holds it to the working plate.

### Holding stamp,

Simultaneously with the vacuum, the holding stamp **2** lowers and presses the sewing piece at a different location against the working plate. The main clamp then picks up the sewing piece for the transfer to the sewing head.

### Cloth clamp

The cloth clamp **5** holds the waistband down until the main clamp picks up the sewing piece.

### Main clamp

The main clamp **4** picks up the sewing piece **3** for the transport to the sewing head by moving forward to the stop rail where it is positioned. The exact position of the main clamp is measured by the photocells at the reflective stripe of the stop rail.

When the main clamp is positioned, it is lowered onto the sewing piece. The attaching devices vacuum and holding stamp are disabled:

The holding stamp is lifted, the vacuum is switched off. The main clamp pushes the sewing piece from the stop rail on the sliding panel to the sewing head.

The main clamp is a compensation clamp that compensates different cloth thicknesses at the waistband.

### Sewing head

The sewing head **7** performs only the functions sewing stitch and thread cutting. All other functions, such as seam curve route or determining the beginning and the end of the seam, are acquired by the sensor system and controlled by the program control unit in accordance with the set values.

The thread stock and the thread supply of the sewing head are monitored by sensors (top thread monitor and bobbin rest thread monitor). The thread holder **1** can hold two thread bobbins.

Fig. 4

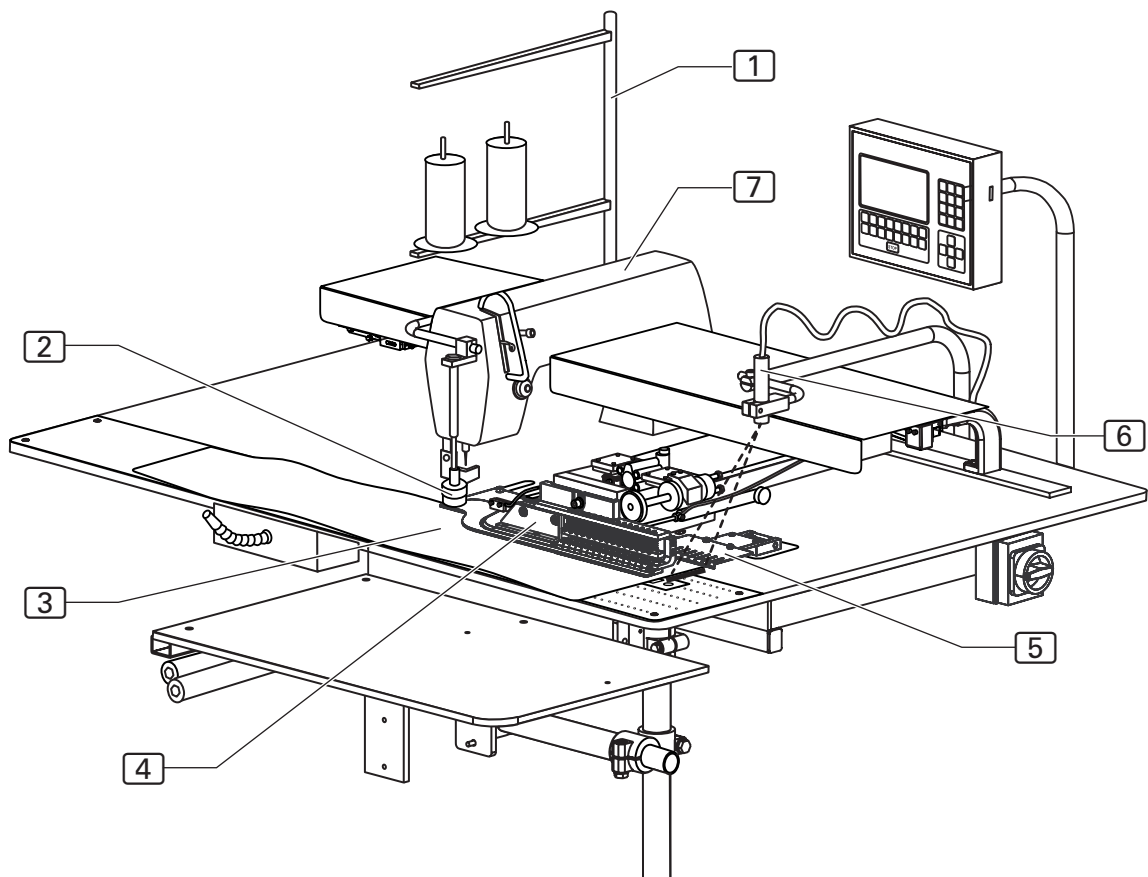

# B.2 Functions of the machine

Fig. 5

The short seam automat is equipped with three different types of switches:

- Emergency switch for stopping a sewing program,
- power supply switch,
- control switches for controlling the machine operation.

## Power supply switch

### Main switch

The main switch **2** is used to turn the power supply of the machine on or off. For safety reasons, the machine must be turned off using the main switch when it is standing still for an extended period; in this case, all functional units are deactivated. The main switch also serves as an additional emergency off switch.

### Vacuum pump switch

The switches **5** and **6** are used for switching the suction system vacuum supply on and off.

- **5** Vacuum pump ON
- **6** Vacuum pump OFF

## Emergency switch

### Key Program STOP

When the key program STOP **1** is pressed, all machine movements and the sewing process are stopped immediately.

The control program performs a reset.

When the footswitch **4** is depressed, the machine moves to zero position and is then ready for operation again.

## Control switches

### Footswitch for bundle clamp

When this footswitch **3** is depressed, the bundle clamp opens. When the switch is released, the bundle clamp closes.

### Footswitch for machine operation

This footswitch **4** is used to control the operating steps of the SHORT SEAM AUTOMATE and to start the fully automatic machine operation.

Fig. 5

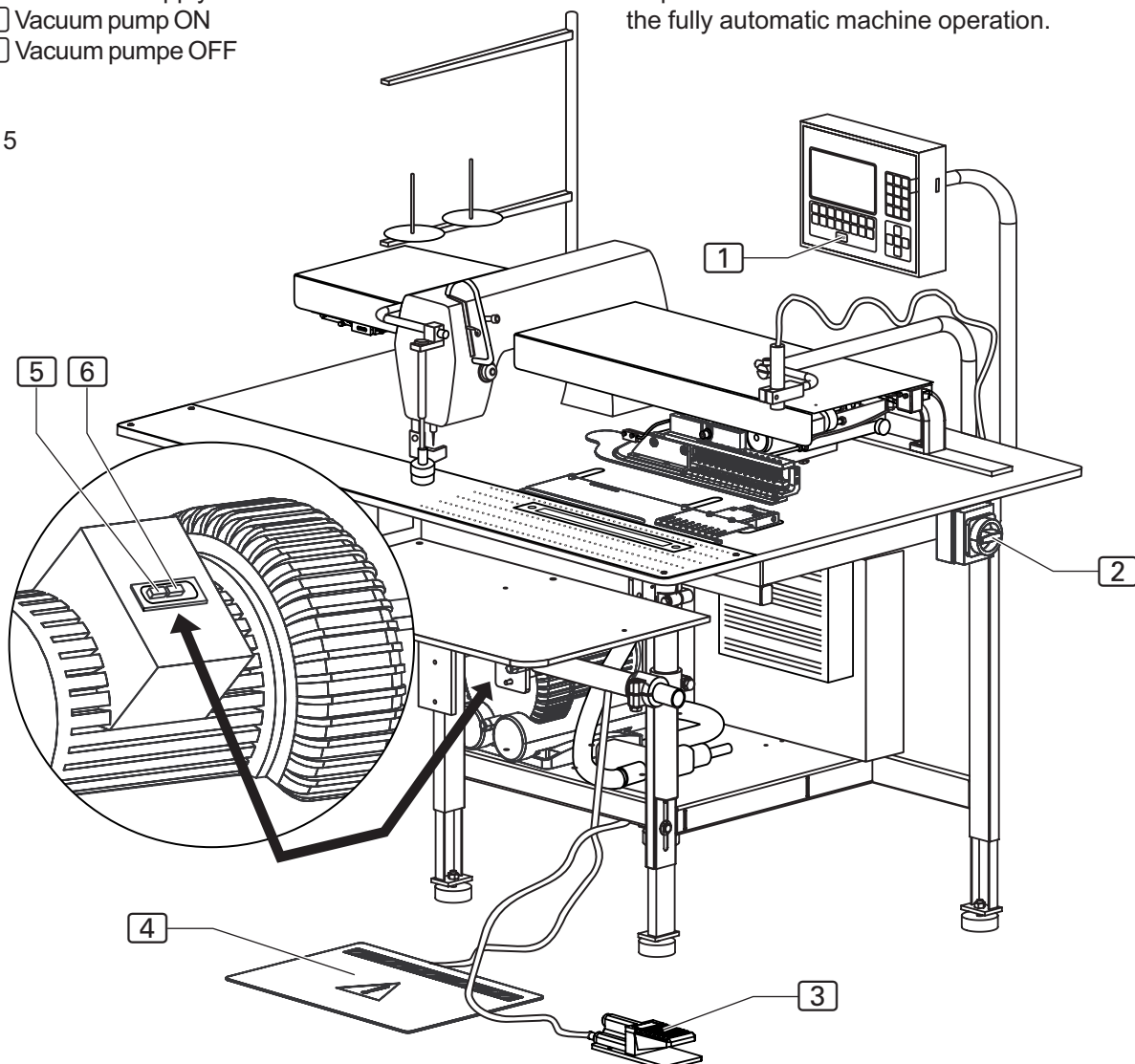



# B.2 Functions of the machine

## B.2.5 Operating panel

Fig. 6

### Display

During the operation of the machine, the display **1** shows the values of the selected sewing program. If menus were requested, the menu symbol or the corresponding parameters of the function are displayed.

### Indicator panel

- 8** Seam symbol
- 9** Sewing program description (a sewing program may consist of several seams)
- 10** Sewing program seam number
- 11** Seam description
- 12** Display field for the enabled seam functions
- 13** Bar for requestable special parameter submenus

### Memory stick slot **3**

The memory stick is the medium for storing the backup copies of all program control data. Programs can be copied to and stored on the memory stick and reloaded into the machine control when required.

### Key Program STOP

If the key Program STOP **6** is pressed during the operation of the machine, all machine movements and the sewing process are stopped.

### Numeric keypad

The numeric keypad **2** is used to enter all changeable number values.

By pressing the M key, you can request the desired sewing programs.

By pressing the P key, you can request submenus, confirm inputs and exit the programming mode.

### Arrow keys

By pressing the UP or DOWN arrow key **4**, you can move the cursor in the selected menu one line up or down.

By pressing the RIGHT or LEFT arrow key, you can mark the desired parameter in the selected menu using the cursor or browse forward or backward if the parameter list consists of several pages.

### Function keys

You can use the function keys **7** to request the menus for setting or changing machine functions on the selected level.

Fig. 6

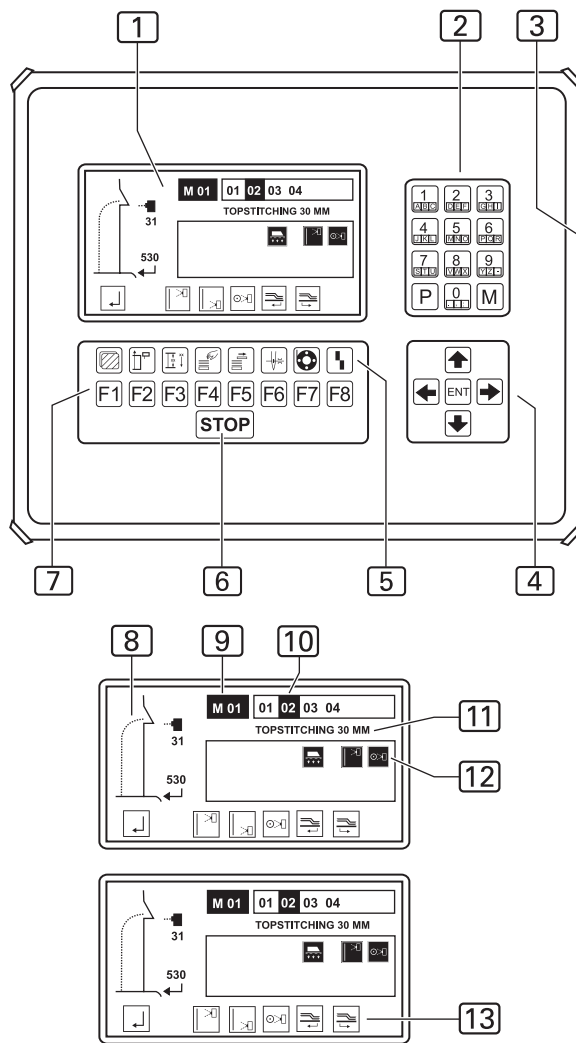

### Symbol bar

The symbol bar **5** indicates menus that can be requested directly from the start menu using the function keys.

All other functions of the machine can be set or changed by selecting the corresponding menus on the different program levels. The corresponding symbols appear on the display of the operating panel.

# B.3 Operation

## B.3.1 Safety instructions for operation

### Machine operation:

 **WARNING - Machine operation intervention!**

The machine is driven by electric motors and by compressed air. Any attempt to stop the moving parts of the machine or to tamper with the movements by hand may cause severe injuries.

- Keep hands away from machine during machine operation!
- During the sewing process, keep hands away from the operating range of the needle!
- If a failure is encountered during machine operation, press the program stop switch immediately!

### Clothing:

 **CAUTION - Unsuitable work clothing!**

The moving parts of the machine may catch and draw in loose clothing which may cause severe injuries.

- When operating the machine, do not wear wide or open clothing!
- Make sure that sleeves are tight-fitting and properly closed!

### Handling the guide laser:

 **CAUTION - Damage of the retina!**

If the eye is directed toward the laser beam for some time, the retina may be damaged.

- Do not look directly into the laser beam!
- Do not direct laser beam into eyes!

 **CAUTION - Laser beam change!**

An optical change of the laser beam may increase its luminous intensity and cause eye injuries.

- If the direction of the laser beam is changed, if the laser beam is misadjusted or if the laser optics are damaged, turn the machine off and shut it down.
- Do not allow optical equipment (burning glasses or lenses) to interfere with the laser beam path.

# B.3 Operation

## B.3.2 Preparing the machine

Fig. 7

Prior to the production start, check the supply connections, connect the machine to the compressed air and power supply systems and prepare the sewing head.

1. Insert needle, pass top thread through needle and insert bobbin for bottom thread into sewing head (see working instructions of sewing head manufacturer or supplier).
2. **Fig. 7:** Connect machine to compressed air supply by inserting the plug-in connector **7** of the compressed air supply hose into the compressed air receptacle in the operating room. The pressure of the compressed air is reduced to the required operating pressure of 6 bar by a pressure reducer **8**. Check manometer **9** to see if the correct operating pressure is set. The pressure reducer is installed at the side mounting wall of the worktable.

### Setting pressures:

The operating pressures are set at the three pressure regulators:

- To increase the pressure, rotate the switch in the clockwise direction.
- To reduce the pressure, rotate the switch in the counter-clockwise direction.

### Function of the pressure regulators:

- Pneumatic spring **1**: approx 0.4 bar, controls the traveling speed of the clamp to the stop.
- Downholder **2**: approx 0.4 bar, controls the pressure of the pressure pad onto the clamp.
- Clamp pressure **3**: 0.4 - 0.5 bar, controls the pressure of the clamp on the sewing material.

### NOTE - Vacuum supply!

If the machine is equipped with the optional vacuum pump, the vacuum supply is now ready for operation.

If the machine is prepared for the on-site vacuum supply system, the on-site vacuum hose **6** must be connected to the sleeve **4** of the vacuum valve **5**.

Fig. 7

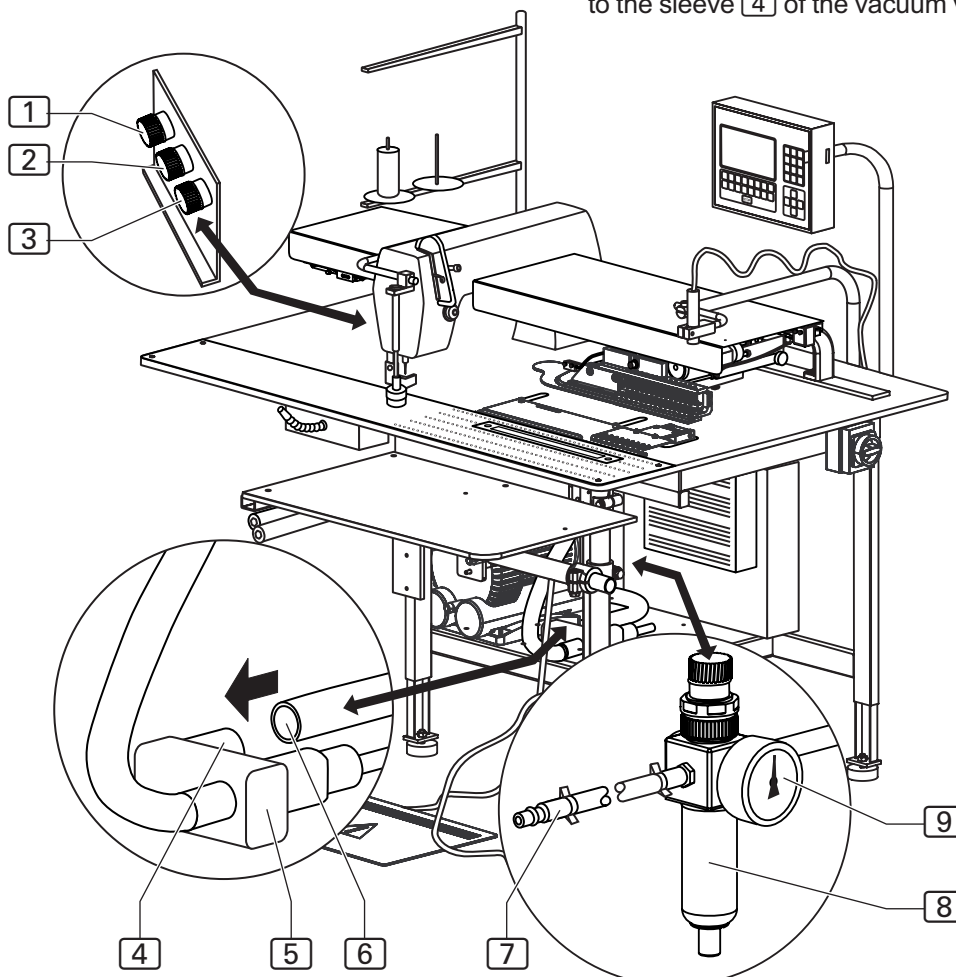

# B.3 Operation

## B.3.2 Preparing the machine

Fig. 8

3. Connect machine to power supply system.

 **WARNING - Electric shock!**

**Contact with current-carrying components may cause a lethal electric shock. Check plug and cable before connecting machine to power supply system.**

- **Do not use damaged plugs, sockets or cables to connect the machine to the power supply system!**
- The machine is connected to a power source of 230 V  $\pm 10\%$  at 50/60 Hz.
- Before connecting the machine to the power supply system, check to see if the ratings of the power supply system in the operating room correspond with the ratings on the nameplate at the rear of the machine.
- If the ratings for voltage (V) and maximum current (A) do not match, the machine must not be connected.
- Insert the grounding plug into a properly grounded and fused power socket.
- Make sure that the power supply cable is not subject to tensile or pressure forces.

4. Turn machine on by moving main switch  to position I.

5. Switch the machine vacuum switch on. Press switch  or open on-site vacuum source.

Fig. 8



# B.3 Operation

## B.3.3 Selecting the sewing program

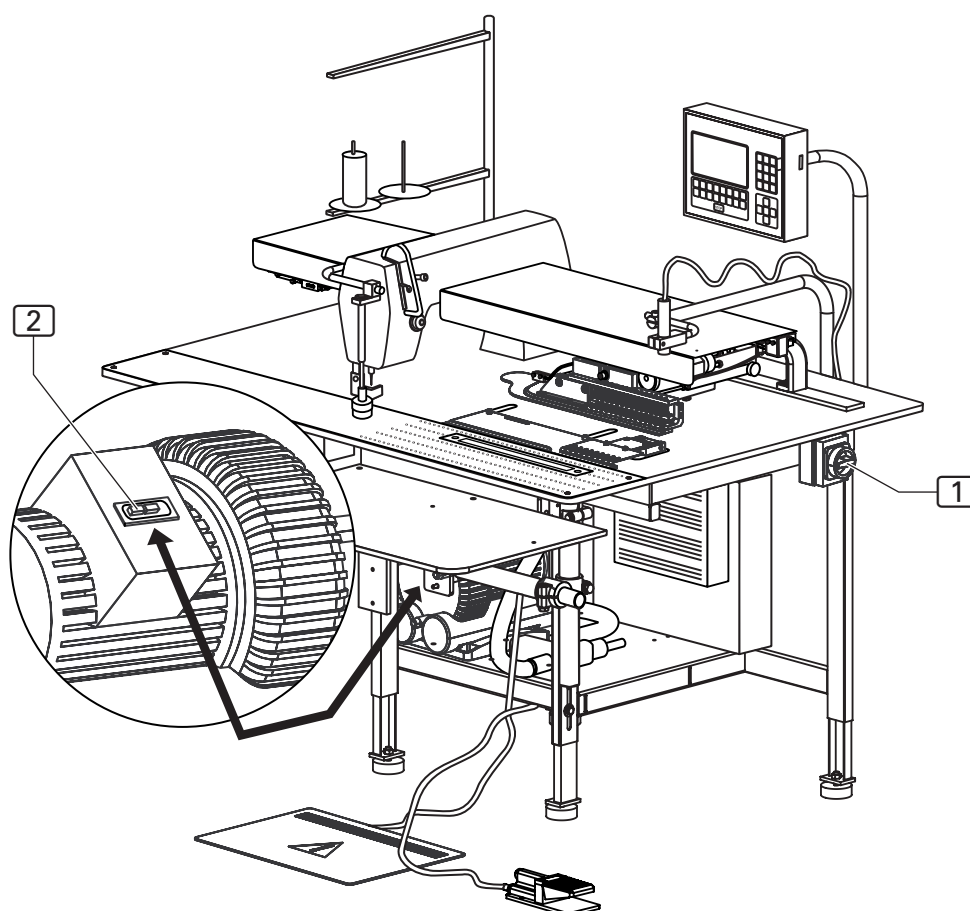
Fig. 9/10

After the machine has been turned on and the control program has been activated, the sewing program that had been selected last is set.

**Fig. 9:** Sewing programs 1 are stored in the memory (**M**). The program control memory can store up to 50 sewing programs (**M 01-M 50**).

For each sewing program, up to six seam numbers 2 (01, 02, 03, 04, 05, 06) can be assigned.

The program control of the machine is equipped at the factory with a standard program:

- Sewing program **M 01** with four different seams for automated stitching of slash selvages. The numbers **(01 - 04)** designate **seams of different stitch widths**.

A sewing program may be combined with one seam, with several seams or with all four seams.

If a sewing program with several seam numbers is requested, the seams are made in the sequence of the seam numbers from left to right.

The sequence of the seam numbers is arbitrary.

Please make sure that the **handwheel** of the main clamp is set correctly for the seam number of the seam that is made first (left position in the line of seam numbers).

1. Select sewing program at operating panel.

Request memory:

- Press M key.

Select sewing program number, e.g. 01:

- Press 0 and 1 keys.

The selected program is activated immediately.

2. Select seam number of desired seam.

Move cursor to seam number:

- Press ← or → key.

Confirm selection:

- Press ENT key.

3. Rotate main clamp handwheel to the selected seam number.

Fig. 9

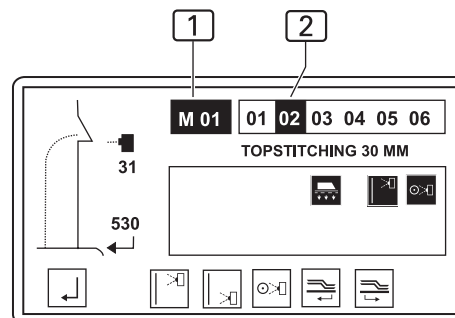
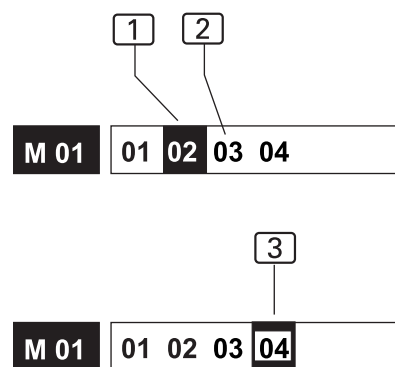

Fig. 10



**Fig. 10:** Display during seam number selection:

- 1 Active seam number
- 2 Passive seam number
- 3 Seam number is selected

# B.3 Operation

## B.3.4 Activating additional seam numbers

1. Select seam number of desired seam.

Move cursor to seam number:

- Press  or  key.

Confirm selection:

- Press  key.

The seam number of the activated seam appears blackened.

## B.3.5 Deactivating a seam number

1. Select seam number of desired seam.

Move cursor to seam number:

- Press  or  key.

Confirm selection:

- Press  key.

The seam number of the deactivated seam is no longer highlighted in black.

## B.3.6 Setting the thread clamp manually

Before the first start of a sewing program, the top thread clamp must be activated to protect the top thread from being pulled out of the needle when the machine starts.



- Press  key.

## B.3.7 Resetting the day counter to zero

Use this function to reset the day counter for a production run or for a completed working cycle to zero.

1. Move to level 1.

- Press  key.

The display shows the symbols for selectable functions on this level.



2. Request the day counter reset function.



- Press  key.

The day counter is now reset to zero.

3. Return to start level.

- Press  key.

Display: PART: 0000

# B.3 Operation

## B.3.8 Selecting the double seam function

**Fig. 11**

The double seam function makes it possible to sew two seams in parallel with only one needle. The machine is capable of producing double seams with a stitch width between 28-46.4 mm.

For this purpose, the machine comes with 3 rollers that need to be inserted depending on the selected stitch width.

To insert a different roller:

1. Flip the cover **2** up.
2. Loosen the screw on the roller **1**.
3. Remove the roller **1**.
4. Fit the desired roller **1**.
5. Tighten the screw.
6. Flip the cover **2** down.
7. Select the double seam function on the control unit (see Section B, Selecting the sewing program).
8. Select the size of the inserted roller **1**.
9. Set the desired stitch width.

Fig. 11

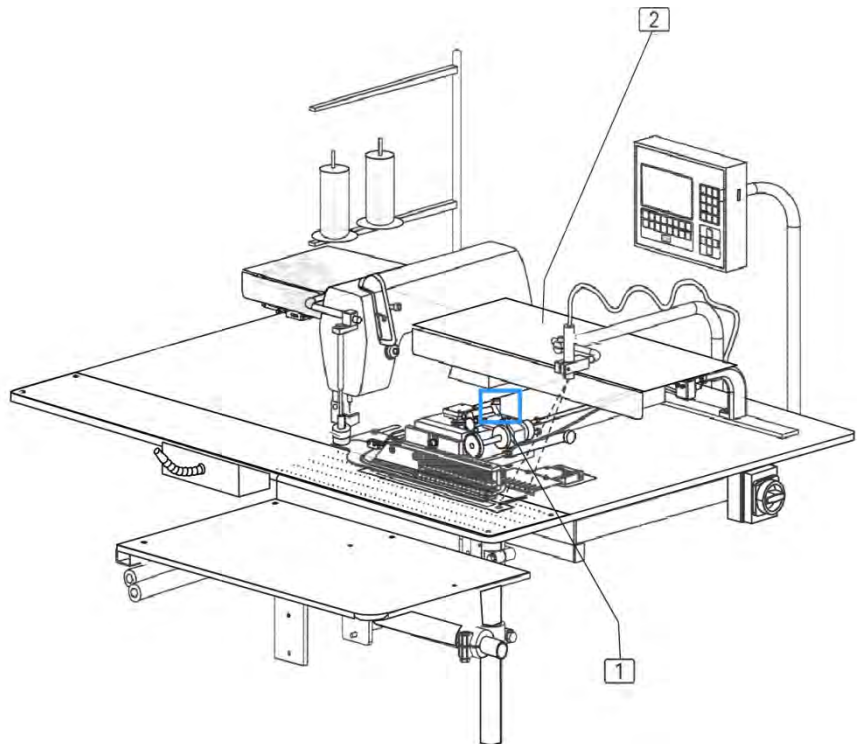

# B.3 Operation

## B.3.9 Aligning sewing pieces

**Fig. 12**

### Alignment using the "Photocell" function, Version 1931-5:

If the "Photocell" function is enabled, the sewing piece is aligned to the stop rail and to the guide laser.

1. Open bundle clamp. Depress and hold footswitch for bundle clamp while the sewing pieces are sorted and prepared in the bundle clamp.
2. Close bundle clamp, release footswitch.
3. Align sewing piece for parallel orientation of seam to the long side of the stop rail [2]. To ensure the correct end point of the seam, line up sewing piece exactly at the red marking line [3] of the guide laser.

#### **NOTE - Reflective stripe!**

The position of the main clamp to the sewing piece is determined by the photocell. The photocell respond to light that is reflected by a reflective stripe [1].

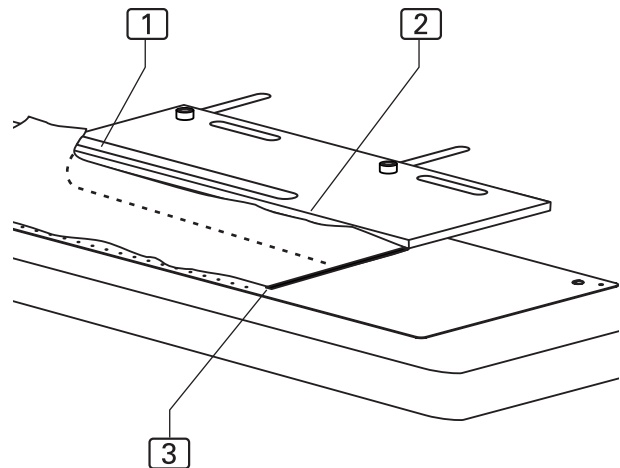
**Fig. 12**



# B.3 Operation

## B.3.10 Starting machine cycle

A machine cycle can be started in three different sequences (mode 00, mode 01, mode 02). The factory default is mode 01 which allows a largely fully automatic machine cycle.

### Controlling machine cycle in mode 00 (fast version):

1. Line up sewing piece.
2. Depress footswitch for machine operation and keep depressed:
  - The vacuum is switched on
3. Release footswitch:
  - The holding stamp is lowered.
  - Further machine cycle is fully automatic: The main clamp picks up the sewing piece and transports it to the sewing head. The sewing piece is tucked and ejected. The main clamp returns to the start position. The next machine cycle starts.

### NOTE - Supplying sewing pieces!

If the fully automatic machine cycle was started, the next sewing pieces can be lined up. The footswitch remains deactivated until the main clamp reaches its start position and the stop rail moves forward; after that, the next machine cycle can be started.

### Controlling machine cycle in mode 01 (slow version):

1. Line up sewing piece.
2. Depress footswitch for machine operation and keep depressed:
  - The vacuum is switched on.
3. Release footswitch:
  - The holding stamp is lowered.
4. Depress, then release footswitch:
  - The main clamp picks up the sewing piece.
5. Depress, then release footswitch:
  - Further machine cycle is fully automatic: The main clamp picks up the sewing piece and transports it to the sewing head. The sewing piece is tucked and ejected. The main clamp returns to the start position. The next machine cycle starts.

Alternatively, mode 01 can be controlled as follows:

1. Depress footswitch for machine operation and keep depressed:
  - The vacuum is switched on.
2. Release footswitch:
  - The holding stamp is lowered.
3. Depress footswitch and keep depressed:
  - The main clamp picks up the sewing piece.
  - Further machine cycle is automatic. When the main clamp moves to the sewing head, the footswitch can be released.

### NOTE - Supplying sewing pieces!

When the sewing piece is transported to the sewing head, the next piece can be lined up. The footswitch remains deactivated until the main clamp reaches its start position and the stop rail moves forward; after that, the next machine cycle can be started.

### Controlling machine cycle in mode 02:

1. Line up sewing piece.
2. Depress footswitch for machine operation and keep depressed:
  - The vacuum is switched on.
3. Release footswitch:
  - The holding stamp is lowered, the sewing piece is picked up by the main clamp.
4. For each further operational step of the machine, depress footswitch.

### NOTE - Supplying sewing pieces!

When the sewing piece is transported to the sewing head, the next piece can be lined up.

## B.3.11 Resetting line-up process

This function depends on the selected machine cycle mode. It refers only to machine movements that can be executed before the start of the automatic process. The machine movements can be reset gradually durch den The machine movements can be reset immediately to the original position by using the activation command.



- Press  key (several times if required).

# B.3 Operation

## B.3.12 Stopping a sewing program

1. Press key Program STOP.  
When this key is pressed, all machine movements and the sewing process are stopped immediately.

To restart the machine after a program stop, all functions must be reset, and the machine must be returned to zero position by unlocking the program stop switch.

## B.3.13 Moving machine to zero position

Prior to starting the production, after machine tests or after corrections to sewing programs, the machine must be returned to zero position for starting the machine cycle:

1. Press program stop switch.
2. Unlock program stop switch.
  - Press program stop twice

## B.3.14 Turning the machine off

For extended work intermissions, the machine must be turned off completely.

1. Turn vacuum supply off by moving vacuum switch to position 0.
2. Turn power supply off by moving main switch to position 0.

## B.3.15 Periodic cleaning of the machine

The machine must be cleaned after large production series or at least once a day, whichever occurs first.



### **CAUTION - Danger of injuries!**

**If the machine is put in motion accidentally, persons in its direct vicinity may be caught by moving parts which may cause injuries.**

**Prior to any cleaning work, disconnect the machine from the power supply!**

- Turn the machine off using the main switch.
- Remove the power plug from the socket and protect it from accidental reconnection.

Periodic cleaning:

1. Remove fabric residues.
2. Using compressed air, blow off dust and thread residues at the sewing head, at the working plate, at the main clamp and at the linear rail.

# **Section C**

## **Service Instructions**

# Section C

## Service Instructions

### Contents

<b>C.1 Delivery of the machine</b> .....	<b>30</b>
C.1.1 Packagin .....	30
C.1.2 Scope of delivery .....	30
<b>C.2 Storage and location requirements</b> .....	<b>31</b>
C.2.1 Floor quality .....	31
C.2.2 Interior climate .....	31
C.2.3 Floor space required .....	31
C.2.4 Supply connections .....	31
<b>C.3 Start-up</b> .....	<b>32</b>
C.3.1 Machine table alignment .....	32
C.3.2 Compressed air .....	33
C.3.3 Vacuum connections .....	34
C.3.4 Connecting the machine to the power supply .....	35
C.3.5 Safety check .....	35
<b>C.4 Operation and shut-down</b> .....	<b>36</b>
C.4.1 Working with the machine .....	36
C.4.2 Machine shut-down .....	36
<b>C.5 Maintenance</b> .....	<b>37</b>
C.5.1 Inspection .....	37
C.5.2 Cleaning .....	37
C.5.3 Service .....	38
C.5.4 Repairs .....	39
Operating panel replacement .....	39
Clamp transport belt replacement .....	40
Switch curve and initiator replacement .....	41
Initiator removal .....	41
Initiator installation .....	41
Clamp rail replacement .....	42

# Section C

## Service Instructions

### Contents

C.5.5	Machine set-up.....	43
	Guide laser adjustment .....	43
	Clamp rail clamping pressure adjustment .....	44
	Clamp rail position adjustment .....	44
	Adjustment of the clamp rail parallel orientation .....	44
	Changing the stitch width.....	45
	Setting the synchronization of the clamp rail and the needle .....	46
	Adjusting the main clamp photocell for seam start at the 1931-5 sewing machine .....	47
	Safety photocell adjustment .....	48
	Installation stepper motor .....	49
	Setting the thread cutter .....	50
	Checking the thread cutter.....	50
	Checking the rest thread monitor .....	51
<b>C.6</b>	<b>Troubleshooting .....</b>	<b>52</b>
<b>C.7</b>	<b>Specifications .....</b>	<b>55</b>

# C.1 Delivery of the machine

## C.1.1 Packaging

The machine is delivered in a solid packaging box on a pallet. All packaging materials can be separated and reused.

- Pallet made of pine wood
- Packaging box made of plywood / transport carton
- Polyethylene film (PE)

 **NOTE - Shipping braces!**

During shipping, moving machine parts are protected with shipping braces (cable ties). The positions of all parts fitted with shipping braces are marked with red labels. After the machine has been installed and aligned, the shipping braces must be removed.

 **NOTE - Damages in transit!**

If any damage presumably caused by incorrect transport is found when the machine is unpacked, please contact your supplier immediately.

## C.1.2 Scope of delivery

The machine is delivered in an operative condition. The scope of delivery comprises:

**Short seam automat with sewing head**

- The machine is equipped with several customer-specific accessories. For checking the exact layout, the information on the delivery note is authoritative.
- Service kit with machine oil.

**Operating panel and program control:**

- Preinstalled (ready-for-use) operating panel.
- Memory card with factory-programmed standard sewing program.

**Technical documents:**

- Operating instructions.
- Service instructions
- Programming instructions.

# C.2 Storage and location requirements

## C.2.1 Floor quality

The floor of the room where the machine is to be installed must have a sufficient surface strength. The location of the machine must be free of vibrations.

If several machines are to be installed in one room, the static load bearing capacity of the ceiling must be considered.

### Weight:

- Machine with accessories approx 200 kg

## C.2.2 Interior climate

### Climatic requirements for the operating room:

The machine must only be stored or operated in closed operating rooms.

- Room temperature +10 °C to +45 °C
- Relative humidity 80 % max.

## C.2.3 Floor space required

For operation during production and for service works, the machine must be freely accessible from all sides. On all sides, there must be a minimum clearance of 1 m.

### Machine dimensions:

- L x W x H 1700 x 1400 x 1700 mm

### NOTE - Electromagnetic interference!

The machine must not be installed in the immediate vicinity of devices or electrical components (e.g. transformers) generating a strong magnetic field as otherwise the correct function of the program control may be impaired.

## C.2.4 Supply connections

The machine requires on-site power and compressed air sources as well as vacuum connections unless the machine is equipped with a vacuum pump.

### Power connection:

The power supply of the machine requires a properly grounded power connection with:

- Grounding plug 230 V ± 10 %, 50/60 Hz
- Fusing 16 A

### NOTE - Peak voltages!

The correct function of the machine requires that the power system supplies a constant current. Peak voltages may particularly impair the stability of the program control.

### Compressed air supply:

The on-site compressed air supply system must meet the following requirements:

- Operating pressure 6 bar
- Compressed air quality oil-free
- Compressed air consumption 4.16 NL

### Vacuum source:

The on-site vacuum source must meet the following requirements:

- Displacement (minimum) 130 m<sup>3</sup>/h

# C.3 Start-up

## C.3.1 Machine table alignment

Fig. 1/2

After the machine has been installed at the desired location, the machine table must be aligned:

- Set machine table to required height.
- Align machine table horizontally on all sides.

### Setting table height:

1. **Fig. 1:** Lift machine: Connect lifting device to lift points (arrows) below the crossmembers. If the machine is equipped with optional transport rollers, release brakes before lifting. If the machine is equipped with a stacker, the stacker must be lifted as well.
2. **Fig. 2:** Loosen lockscrews **2** on all guide rails.
3. Pull table legs **3** out to the desired length and retighten lockscrews **2**.
4. Lower machine to floor.

### Horizontal positioning of the machine table:

1. Place bubble level onto working plate.
2. **Fig. 2:** Loosen table leg lock nuts **1**.
3. Align machine table horizontally on all sides by raising or lowering table legs as required.
4. Retighten table leg lock nuts.

### NOTE - Shipping braces!

Before the machine is connected to the energy supply sources, all shipping braces must be removed.

- Cut off cable ties.
- Remove labels.

Fig. 1

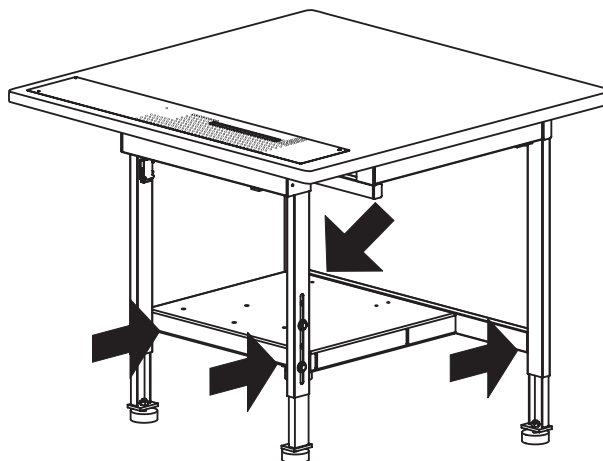
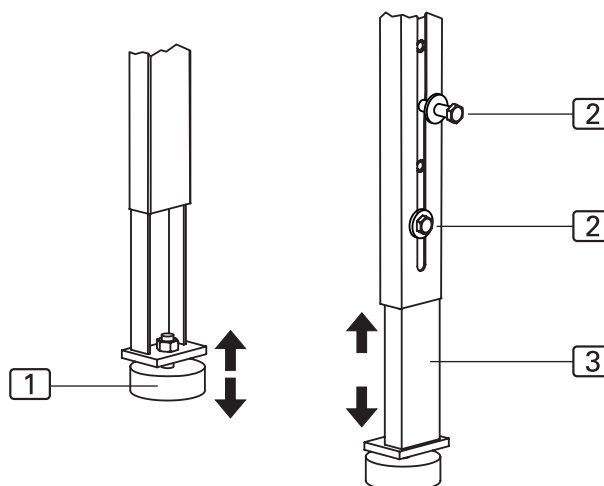

Fig. 2





# C.3 Start-up

## C.3.2 Compressed air

**Fig. 3**

The compressed air connection is preinstalled on the machine. It comprises the following components:

- Pressure reducer [6] with manometer [7] and water separator [5],
- Pressure hose with push-in plug [4].

The pressure reducer is mounted to the side mounting wall of the worktable.

### Connecting the machine to the compressed air supply system:

1. Connect pressure hose plug to on-site terminal unit.
2. Open on-site compressed air supply.
3. Set pressure reducer to a machine operating pressure of 6 bar by rotating pressure reducer knob [8] and read value on manometer [7]:
  - To increase pressure, rotate in clockwise direction,
  - To reduce pressure, rotate in counter-clockwise direction.

### Setting pressures:

The operating pressures are set at the three valves:

- To increase the pressure, rotate the switch in the clockwise direction.
- To reduce the pressure, rotate the switch in the counter-clockwise direction.

### Function of the pressure regulator:

- Pneumatic spring [1]: approx 0.4 bar, controls the traveling speed of the clamp to the stop.
- Downholder [2]: approx 0.4 bar, controls the pressure of the roller on the clamp.
- Clamp pressure [3]: 0.4 - 0.5 bar, controls the pressure of the clamp on the sewing material.

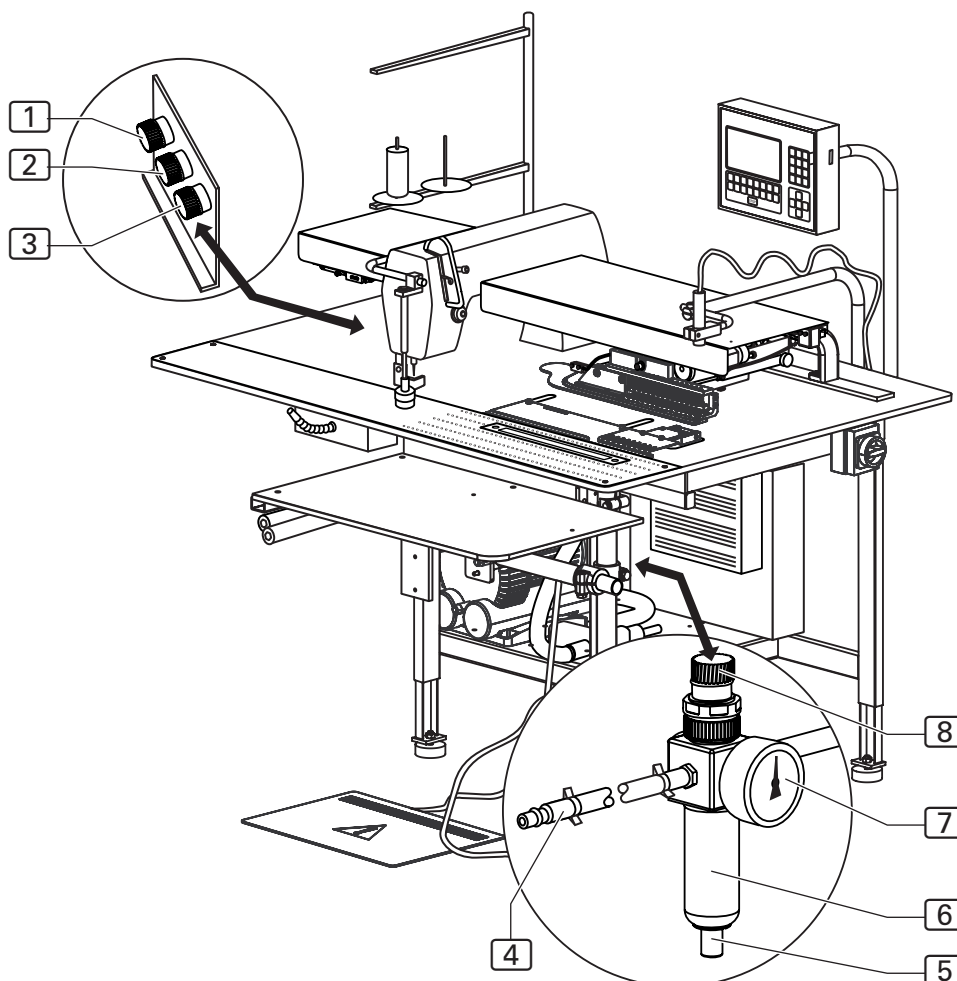
**Fig. 3**

# C.3 Start-up

## C.3.3 Vacuum connections

**Fig. 4**

If the machine is equipped with the optional vacuum pump, no installation is required; the vacuum supply system is ready for operation.

If the machine is not equipped with a vacuum pump, it must be connected to the on-site vacuum source. The vacuum valve is located on the lower storage surface of the worktable.

### NOTE - Required components!

The following components must be available on-site:

- A vacuum hose with a minimum inner diameter of 1¼" or (as required) an adapter or reducer for connecting the on-site vacuum hose to the sleeve (outer diameter 1¼") of the vacuum valve on the machine.
- A hose clamp with a minimum inner diameter of 1¼".

1. Connect on-site vacuum hose **4** to sleeve **2** of vacuum valve **3**.
2. Make sure that the vacuum hose **1** to the table plate has been attached correctly and securely.
3. Open on-site vacuum source.

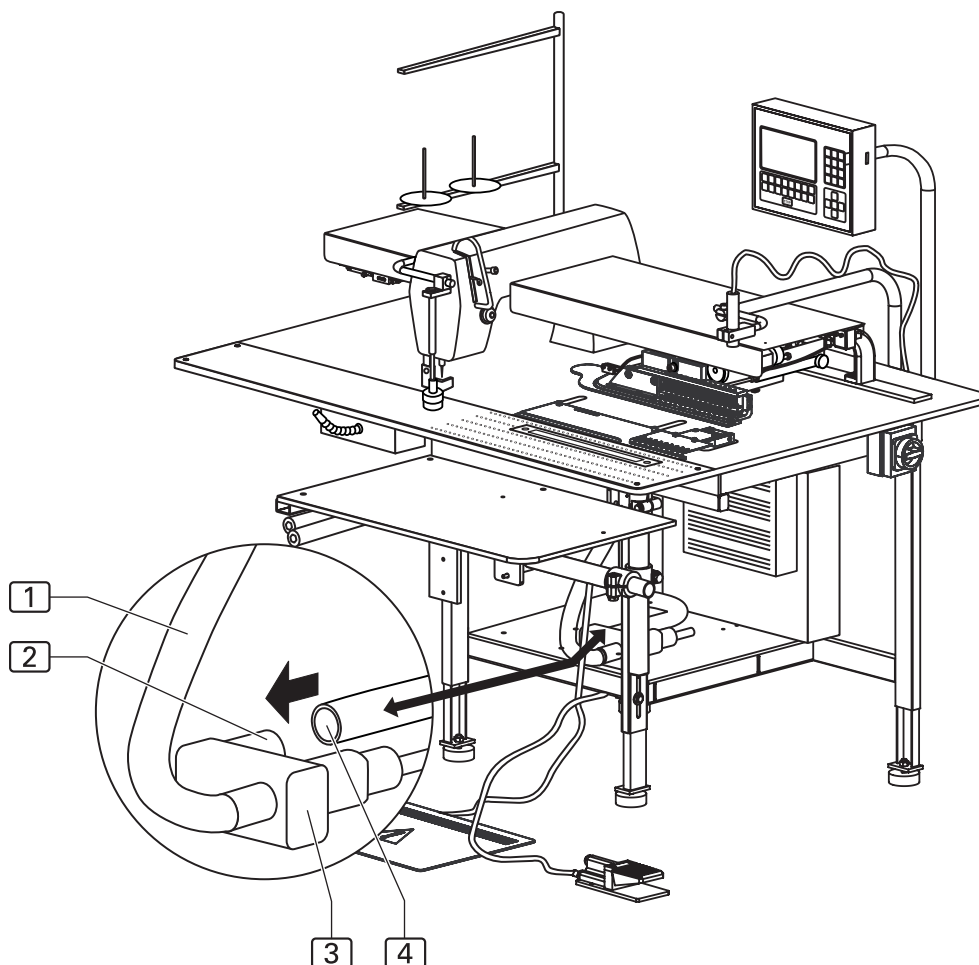
**Fig. 4**

# C.3 Start-up

## C.3.4 Connecting the machine to the power supply

The power cable and the power plug are preinstalled on the machine. The footswitches for controlling the machine operation and the bundle clamp are installed as well.

### Connecting the machine to the power supply system:

1. Put footswitches for machine operation and for bundle clamp onto desired locations on floor at front side of machine.
2. Insert power plug into socket.



### WARNING - Electric shock!

**Contact with current-carrying components may cause a lethal electric shock. Check plug and cable before connecting machine to power supply system.**

- **Do not use damaged plugs, sockets or cables to connect the machine to the power supply system!**
- **The machine is connected to a power source of 230 V  $\pm$ 10 % at 50/60 Hz.**
- **Before connecting the machine to the power supply system, check to see if the ratings of the power supply system in the operating room correspond with the ratings on the nameplate at the rear of the machine.**
- **If the ratings for voltage (V) and maximum current (A) do not match, the machine must not be connected.**
- **Insert the grounding plug into a properly grounded and fused power socket.**
- **Make sure that the power supply cable is not subject to tensile or pressure forces.**
- **Route the power supply cable in a way that ensures free access to and around the machine.**



### NOTE - Works to the electrical system!

Works to the electrical system of the machine must only be carried out by qualified and authorized expert personnel. Tampering with the machine without authorization makes the warranty void.

## C.3.5 Safety check

Before the machine is released for operation, all safety devices must be checked for their correct operation.



### CAUTION - Danger of injuries!

**The safety devices protect the operating and service personnel while working on or with the machine. If the safety devices are fully or partially inoperative, the machine must not be started up.**

### Perform safety check:

1. Check to see if the cover above the clamp transport unit is correctly and safely installed.
2. Check to see if the finger protection at the sewing head covers the needle effectively.
3. Make sure that the guide laser is not directed into the view area of the machine operator.
3. The main switch also serves as an emergency off switch. To check the function of this switch, turn the machine on, start a machine cycle and turn the machine off during the tucking process using the main switch. All operational movements of the clamp and of the sewing head must stop, and the program control must switch off.
4. Check the function of the key Program STOP. Start a machine cycle and press the key. All operational movements of the clamp and of the sewing head must stop.
5. Unlock the key Program STOP. The program control starts a reset, and the clamp must return to its start position.

**The machine is ready for operation.**

# C.4 Operation and shut-down

## C.4.1 Working with the machine

### Factory settings:

The machine has a factory-programmed standard program (**M 01**) with four seams (**01, 02, 03, 04**) and different **stitch widths**.

This sewing program is so powerful that it can be used for production.

It is furthermore perfectly suited for training operating personnel and can be used as a template for programming customer-specific sewing programs.

For details about the programming of sewing programs, please refer to Section D of the working instructions.

## C.4.2 Machine shut-down

When the machine is to be shut down, it must be disconnected from all energy supply sources.

### Disconnecting the machine from the power supply system:

1. Turn machine off using main switch. Move switch to position "0".
2. Remove power plug from socket and protect it against accidental reconnection.

### Disconnecting the machine from the compressed air / vacuum supply system:

1. Shut off on-site compressed air / vacuum.
2. Remove compressed air hose plug from terminal unit.

 **NOTE - Dust-proof protection!**

If the machine is to be shut down for an extended period of time, it should be covered with a plastic tarpaulin.

# C.5 Maintenance



## WARNING - Electric shock:

Contact with current-carrying components may cause a lethal electric shock

If the machine is put in motion accidentally, persons in its direct vicinity may be caught by moving parts which may cause injuries.

Prior to any service, cleaning or maintenance works, disconnect the machine from the power supply system!

- Turn the machine off using the main switch.
- Remove power plug from socket and protect it against accidental reconnection.
- If the power supply is not required for repair or set-up work, the machine must be disconnected from the power supply system.

### C.5.1 Inspection

The machine must be inspected annually.

The inspection comprises particularly the following items:

- safety devices of the machine,
- operativeness of the program control,
- correct function of inputs and outputs.

### C.5.2 Cleaning

The machine must be cleaned after large production series, or at least once a day, whichever occurs first.

#### Cleaning the machine surfaces:

1. Disconnect machine from power supply system.
2. Remove fabric residues.
3. Using compressed air, blow off dust and thread residues at the sewing head, at the working plate, at the clamp and at the linear rail.
4. Wipe machine parts dry using a dry, clean cloth.



#### NOTE - Plastic surfaces!

Some parts of the machine surfaces are made of plastic materials. Solvents may dissolve plastics and make them unusable.

Do not clean the machine surfaces (particularly the operating panel) with cleaning agents that contain solvent.

# C.5 Maintenance

## C.5.3 Service

## Fig. 5

The following service works must be carried out in weekly intervals.

### Oiling the clamp rail:

1. Disconnect machine from power supply.
2. Wipe clamp rail clean using a soft, oil-saturated cloth.  
The scope of delivery comprises 0.25 l of oil. When this oil is used up, you can order the special machine oil for service from the manufacturer or supplier of the machine.

### Emptying the water separator:

1. Disconnect machine from power supply.
2. Drain water at pressure reducer water separator into suited container.  
Press button **1** at pressure reducer collector and keep pressed until all the water has been drained.

### NOTE - Sewing head!

For information about service of the sewing head, please refer to the working instructions of the sewing head.

Fig. 5

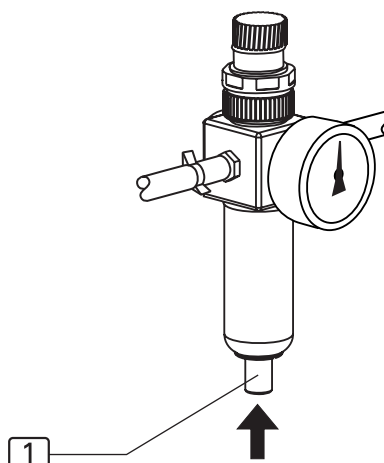

# C.5 Maintenance

## C.5.4 Repairs

**Fig. 6**

Any repairs to the machine must only be carried out by:

- authorized Technical Service,
- personnel that has been instructed about the setting up and maintenance of the machine on the occasion of a training by the supplier or manufacturer of the machine.

Use only original spare parts for installing or replacing machine components.

Manufacturer and supplier will not be held responsible for spare parts from third parties.

 **NOTE - Programming instructions!**

Repairs require that machine components carry out their individual movements and that the machine movements are tested. These functions are controlled on level 1 of the service menu.

For the necessary instructions, please refer to the programming instructions section D.

### Operating panel replacement:

1. Disconnect machine from power supply.
2. Remove two lock screws **4** and disconnect interface connector **5**.
3. Remove operating panel **1**, position replacement part and secure it using screws.
4. Copy sewing programs: Insert memory stick **3** into socket **2** (see Section D, Programming Instructions).

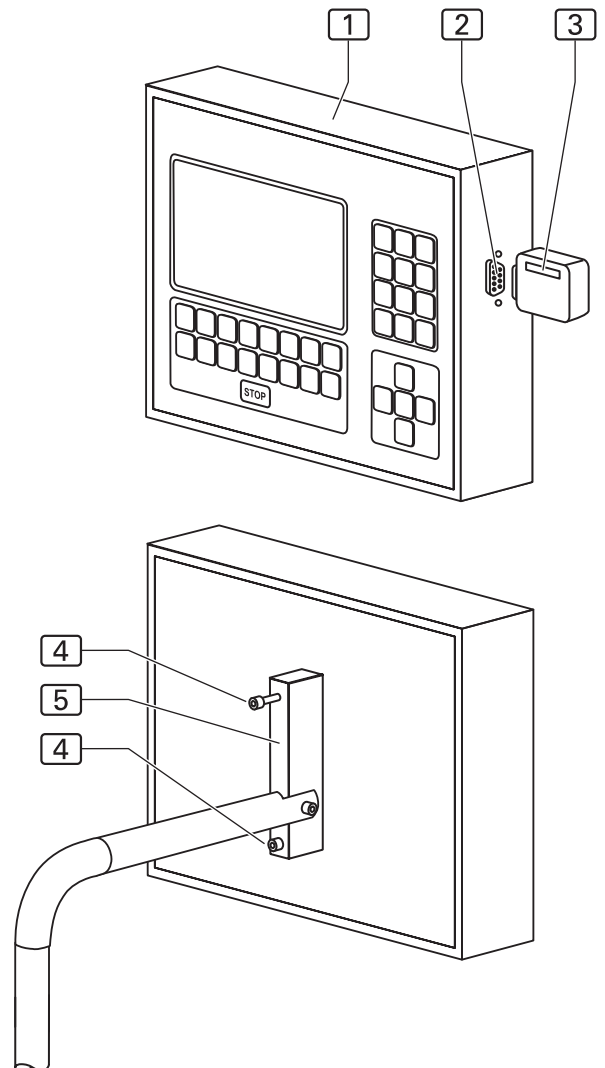
**Fig. 6**

# C.5 Maintenance

## C.5.4 Repairs

Fig. 7/8

### Clamp transport belt replacement:

1. Disconnect machine from power supply system.
2. **Fig. 8:** Remove retaining screws [3] from drive roller cover [2] and remove cover.
3. Remove two retaining screws from slide roller cover [10] and remove cover [11].
4. Loosen two belt lock screws [5] and release belt tension [8].
5. Loosen lock nuts [7] of set screws [6] and rotate two set screws backward.
6. Remove belt and open connector [4].
7. **Fig. 7:** Remove two connecting screws [1]. Separate upper part [2] from lower part [4] of connector.
8. Push clamp to left end position until it reaches the stop.
9. **Fig. 8:** Install belt over guide pulley [9] to drive roller [1] and slide roller [12].
10. **Fig. 7:** Position connector and secure it using the screws.

### NOTE - Connector alignment!

To prevent the connector from moving over the drive or guide rollers during clamp transport, the connector must be positioned at a distance of exactly 60 mm from the right end point of the clamp transport.

Fig. 7

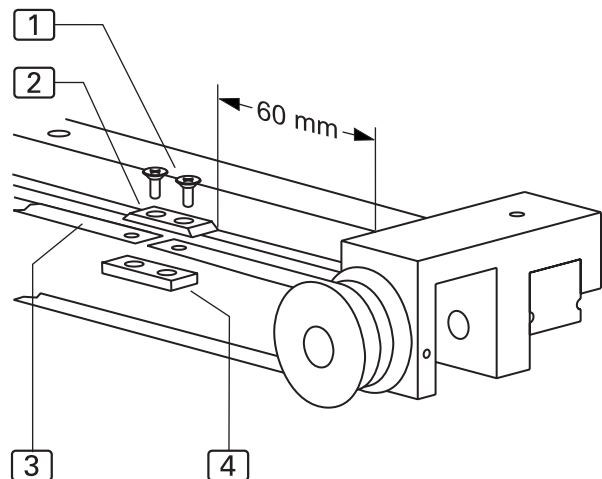

11. The ends of the belt 3 are fitted with holes. Install the upper and lower part exactly over the holes of the belt and connect the two parts and the belt using the connecting screws.
12. **Fig. 8:** Tension belt by tightening two set screws [6] until the belt can be depressed approx 10 mm with distinct counterpressure at the middle of the linear rail. Tighten lock nuts [7] and lock screws [5].
13. Install the two covers [2] and [11].

Fig. 8

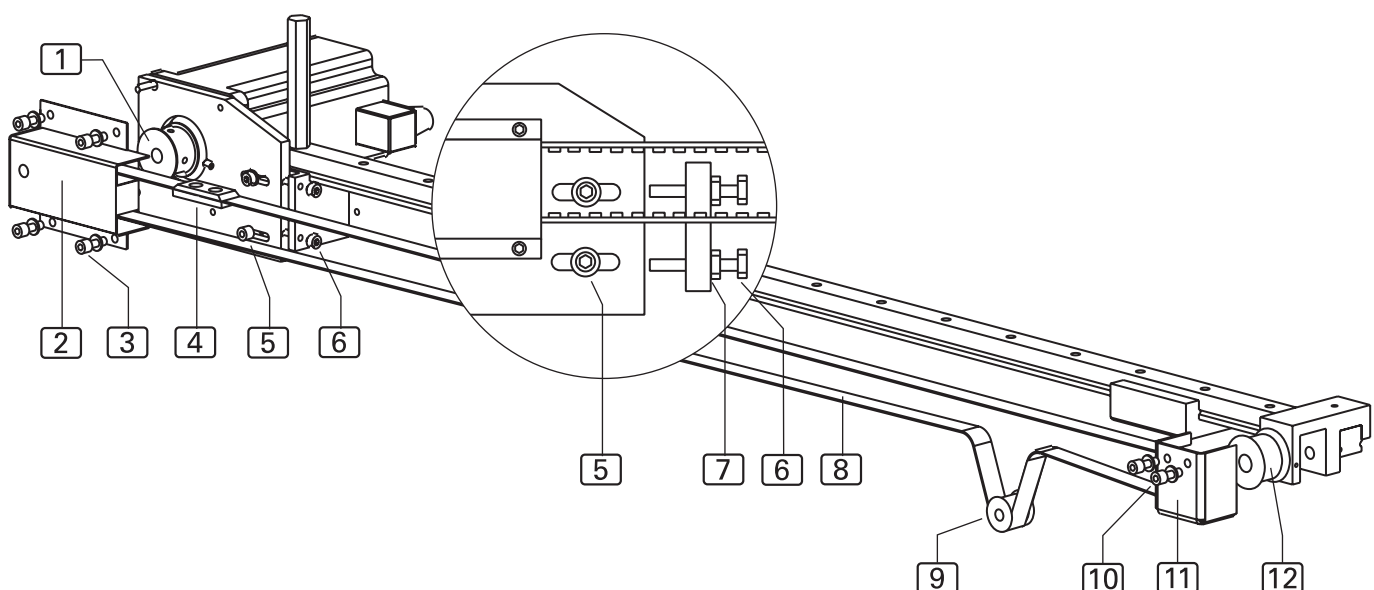



# C.5 Maintenance

## C.5.4 Repairs

Fig. 9

### Switch curve and initiator replacement:

To allow activation of the reversing device of the sewing drive, the toothed disk of the sewing drive must have a switch curve installed at a certain distance to an initiator (24 V PNP two-wire version).

### Initiator removal:

1. Disconnect machine from power supply system.
2. Disconnect initiator connecting line connector [8] from receptacle of sewing motor control unit. The sewing motor control unit is located at the lower storage shelf of the worktable.
3. Remove lock nut [2] and rotate initiator out of the guide nut [1] of the holder [7].

### Initiator installation:

1. Install lock nut [2] to initiator and install initiator into guide nut [1] of holder [7].
2. Remove retaining screws [5] from switch curve [4] on toothed disk [6]; do not remove switch curve screws [6].
3. Install initiator [3] at distance **A** of 1 mm from switch curve. Rotate initiator into position in guide nut [1] and secure it using lock nut [2]. The distance **B** between toothed disk [6] and initiator [3] must be 0.5 mm.
4. Connect initiator connecting line connector [8] to receptacle of sewing motor control unit.

### Switch curve adjustment:

1. Turn machine on.
2. Rotate sewing head handwheel in direction of machine rotation until the thread lever reaches the highest point (pinning position **C**).
3. Then, rotate sewing head handwheel in counterdirection until the first pinning position **B** is reached.
4. Block handwheel by depressing pinning pin of hole at position **B** to the left of handwheel.
5. Rotate switch curve until initiator receives switch contact in direction of rotation exactly at switch curve.
6. Secure switch curve using two retaining screws [5].
7. Set global parameters (see programming instructions):  
For global parameter 35 (thread lever top position), set value 000.  
For global parameter 39 (thread lever reversing angle), set value 25.

### Global parameter setting:

- Für global parameter 39 (thread lever reversing angle), set value 25 INC (see Section D, Programming Instructions).

Fig. 9

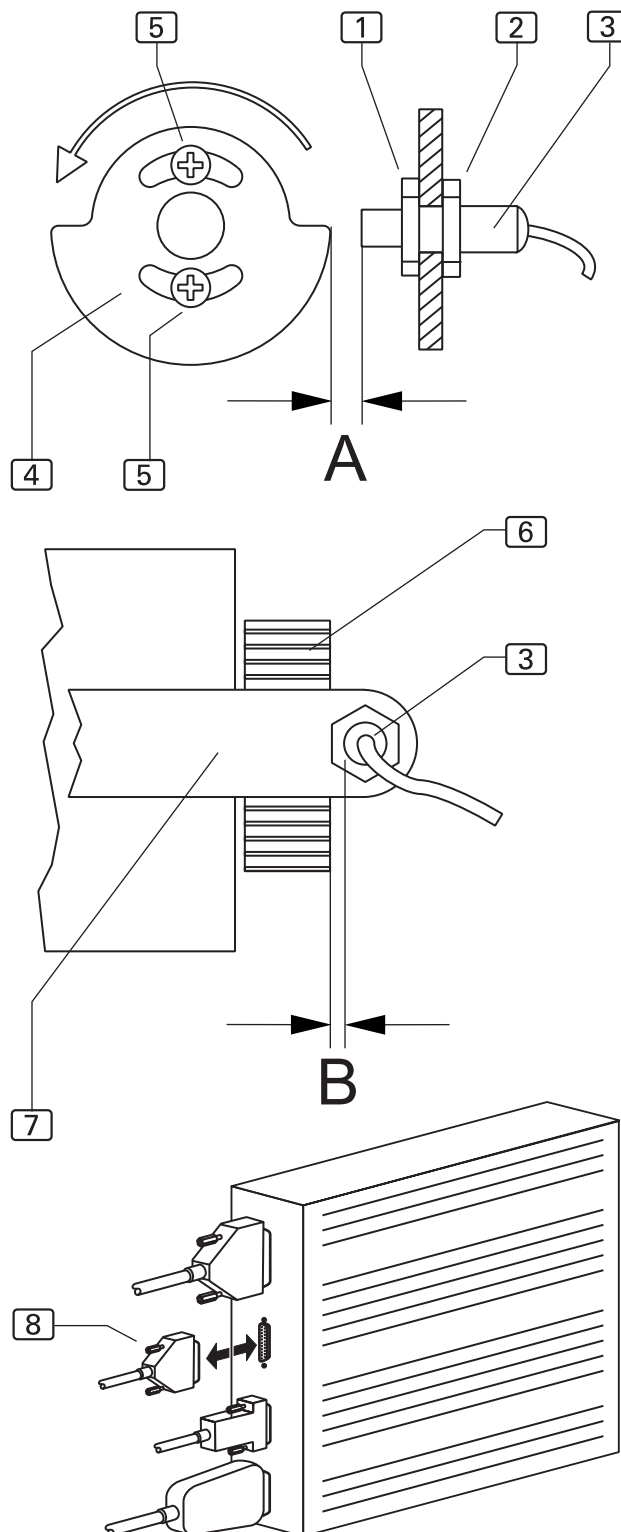

# C.5 Maintenance

## C.5.4 Repairs

**Fig. 10****Clamp rail replacement:**

The clamp rail must be replaced if the protective lining at the bottom side of the rail is worn.

**Clamp rail removal:**

1. Lift main clamp.
2. Loosen retaining screw **2**.
3. Pull clamp rail **1** down and remove.

**Clamp rail installation:**

1. Insert clamp rail **1** into fixture **3** and push up until it reaches the stop. Make sure the clamp rail is positioned evenly in the fixture.
2. Tighten retaining screw **2**.

Fig. 10

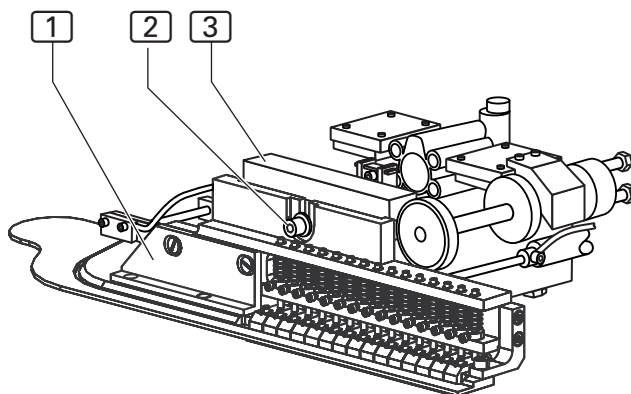

# C.5 Maintenance

## C.5.5 Machine set-up

Fig. 11

### NOTE - Activating inputs/outputs!

To allow for testing machine movements or interval operation, the individual stages of movement can be activated with the inputs/outputs of the machine control unit (see programming instructions, Section D.4.3., Service menu level 1).

Usually, the setting up of the machine is controlled by parameter values of the sewing programs (special parameters) and the parameter values of the machine control unit (global parameters). The following mechanical changes may be required additionally to ensure correct seams with the set parameter values.

#### Guide laser adjustment:

The guide laser marks the line-up position of simple labels on the pocket edge. The position of the guide laser can be adjusted vertically and horizontally.

Adjusting the bracket height:

1. Loosen retaining screw **4** at rear of worktable.
2. Position laser light bracket **3** in the desired height.
3. Tighten retaining screw **4**.

Vertical adjustment for tilting the laser light into the desired position:

1. Loosen lock screw **2**.
2. Rotate laser light angular bracket **6** to desired position.
3. Tighten lock screw **2**.

Horizontal adjustment for achieving a 90° angle to the stop rail:

1. Loosen lock screw **1**.
2. Rotate laser light **5** to desired position.
3. Tighten lock screw **1**.

Fig. 11

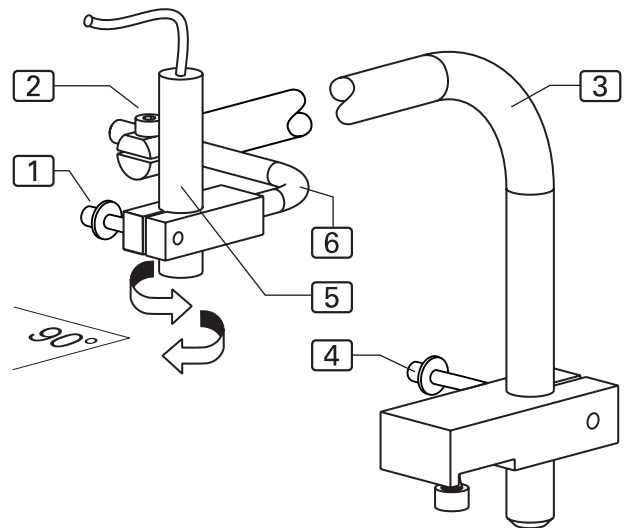

# C.5 Maintenance

## C.5.5 Machine set-up

After any works to the main clamp, the clamping pressure and the alignment of the clamp rail to the needle must be checked.

### Clamp rail clamping pressure adjustment:

1. Check to see if the main clamp exerts pressure to the sewing piece evenly along the entire length of the rail by lining up a piece of fabric to the insertion position and lowering the main clamp.
2. Check clamping pressure by trying to pull the sewing piece out of the clamp at several locations along the clamp rail.
3. **Fig. 12:** If clamping pressure is irregular or insufficient, remove clamp rail **1** and adjust pressure using the two adjustment screws **2** on the inner side of the clamp rail.  
Tightening the adjustment screws will increase pressure of clamp rail to working plate as the overall height **H** of the main clamp increases.
4. Repeat adjustment and recheck with lowered main clamp until clamping pressure is distributed evenly along the entire length of the clamp rail.

### Clamp rail position adjustment:

1. Lower main clamp.
2. Depressurize machine by disconnecting the compressed air hose of the machine from the on-site compressed air supply system.
3. Move main clamp manually under sewing head and use manual drive to lower needle into groove on clamp rail.
4. **Fig. 13:** Check to see if needle **5** is centered in groove **4** of clamp rail **1**. If not OK, change orientation of clamp rail to needle.
5. Loosen screw **3** at bottom of main clamp, reposition clamp rail, then tighten screw.

### Adjustment of the clamp rail parallel orientation:

1. Check to see if the sewing head needle is positioned exactly central to the groove along the entire length of the rail by moving the main clamp under the sewing head.
2. **Fig. 13:** If the position is not parallel, loosen eight clamp bracket retaining screws **2** and move clamp rail to parallel position.
3. Tighten clamp bracket retaining screws and recheck parallel orientation of clamp rail.

Fig. 12/13

Fig. 12

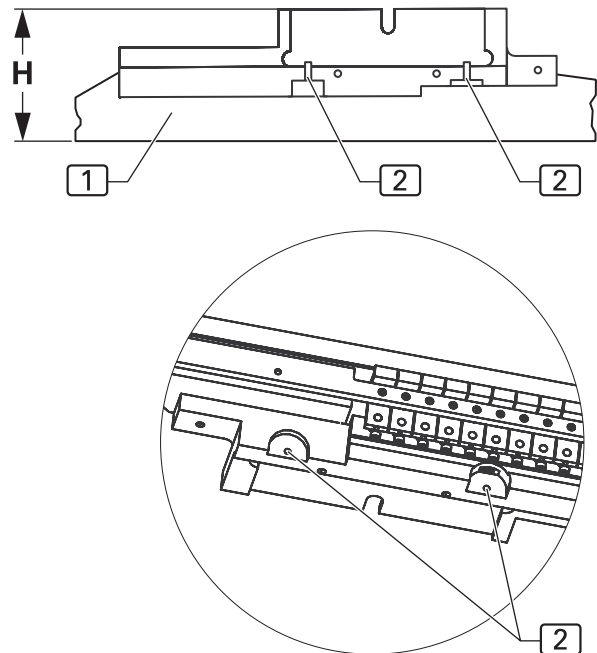
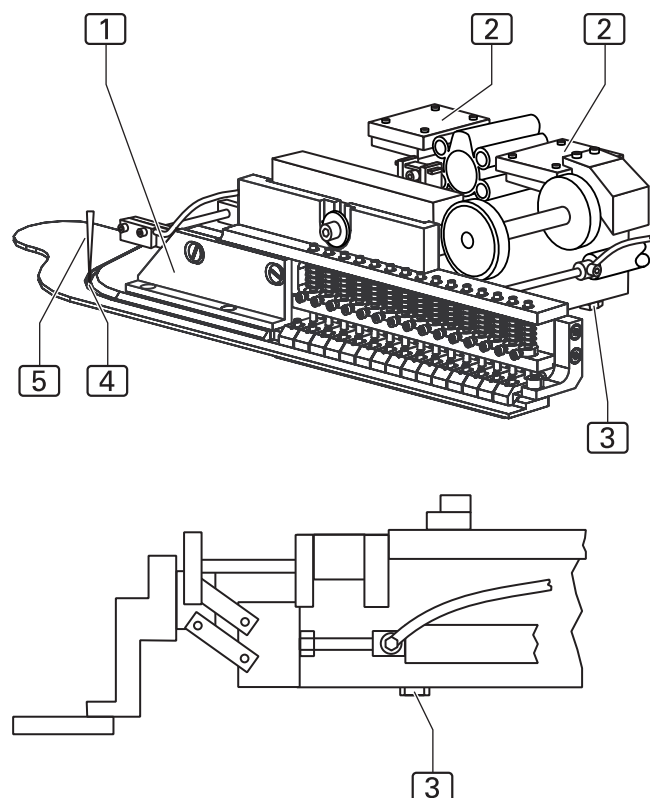

Fig. 13



# C.5 Maintenance

## C.5.5 Machine set-up

### Changing the stitch width:

The correct stitch width setting is determined by trial and error. It can be set to any value between 29 and 40 mm by changing the stop [1] at the right side of the main clamp.

1. Disconnect machine from power supply.
2. Using the handwheel [2], select the number of the seam whose width is to be set.
3. Set stop screw [3] of selected seam to stitch width by loosening lock nut [4] and rotating stop screw to desired length. The overall length of the stop screw corresponds with the stitch width of the seam.
- Set the stitch width so that the distance between the stop [6] and the needle [7] is measured from the center of the milling [8] of the clamp rail [5].
4. Tighten lock nut [4] and recheck stitch width at sewing piece.

Fig. 14

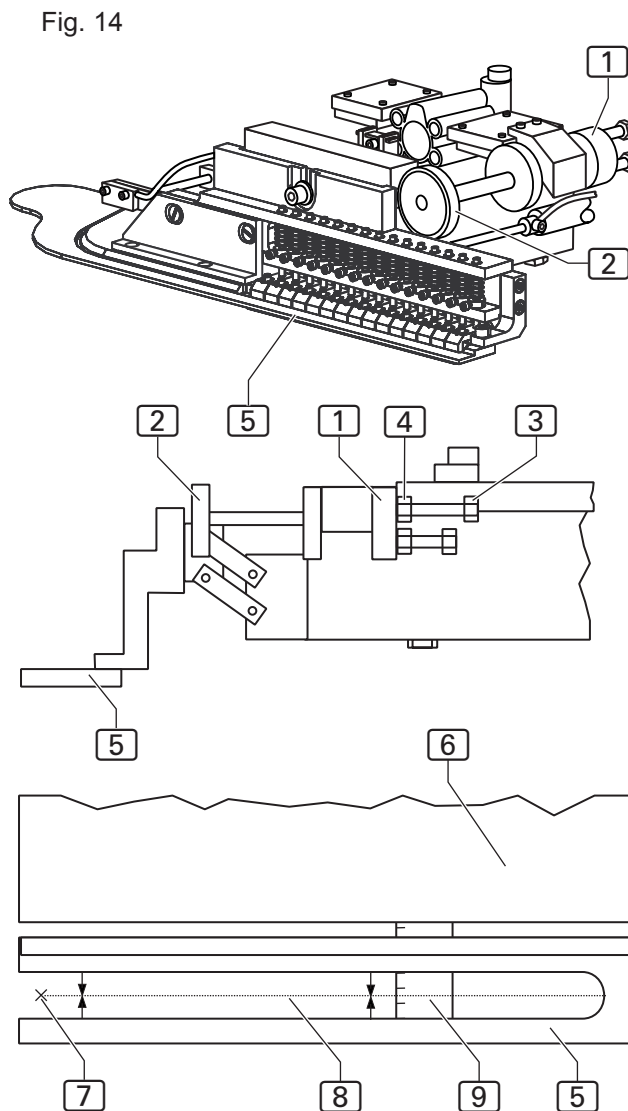

# C.5 Maintenance

## C.5.5 Machine set-up

Fig. 15

### Setting the synchronization of the clamp rail and the needle:

The synchronization of the clamp rail and the needle is determined by three switching settings.

- When the main clamp **5** approaches the control curve **4**, the driver roller **3** repositions the switch tag **2** during this movement.
- The switch tag activates the initiator **1** which reduces the main clamp traveling speed to the preset value.
- If the switch tag is completely shifted against the control curve, the initiator **7** which starts the sewing process is activated.

### Setting procedure:

1. Lower main clamp.
2. Depressurize machine by disconnecting the compressed air hose of the machine from the on-site compressed air supply system.
3. Move main clamp manually under sewing head.
4. Check contact point of initiator **1**. While the switch tag **2** is not in contact with the pin **3**, the initiator must not be in contact (indicator must not light). If the initiator has permanent contact, loosen initiator lock nut and unscrew initiator to switch-off point, then tighten lock nut.
5. Push switch tag **2** to control curve **4** until it reaches the stop. If switch tag and control curve are flush, the initiator **5** must have contact (indicator lights).
6. If the initiator does not have contact when the switch tag **2** is in this position or if the initiator is activated when the switch tag is in a different position, change the position of the slide **6**.
7. Loosen the two lock screws of the slide and move the slide with the initiator to the exact contact point.
8. Tighten the two lock screws **4**.

Fig. 15

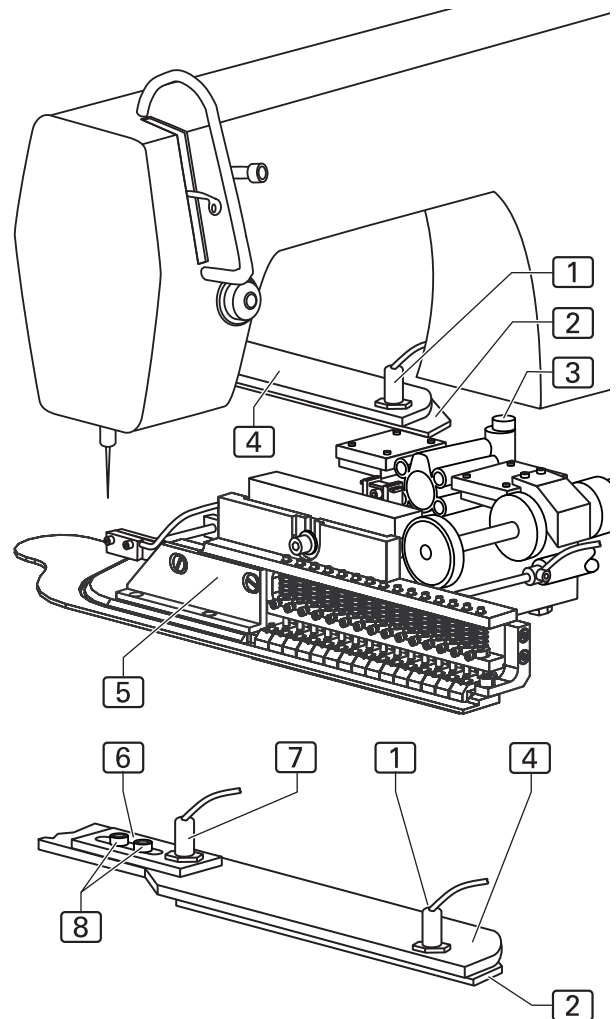

# C.5 Maintenance

## C.5.5 Machine set-up

Fig. 16

### Adjusting the main clamp photocell for seam start at the 1931-5 sewing machine:

The side movement of the main clamp to the front is controlled by the position of the photocell **1** over the reflective stripe **3**. The red scanning spot of the photocell must be directed to the center of the reflective stripe **3**. This position is set by a stop **4** at the left side of the main clamp.

1. Move main clamp sideways to front and check position of scanning spot.
2. To reposition the stop, loosen stop set screw **4**.
3. Move stop slide ring along guide rod **2**, then tighten set screw.
4. Check main clamp movements.

Fig. 16

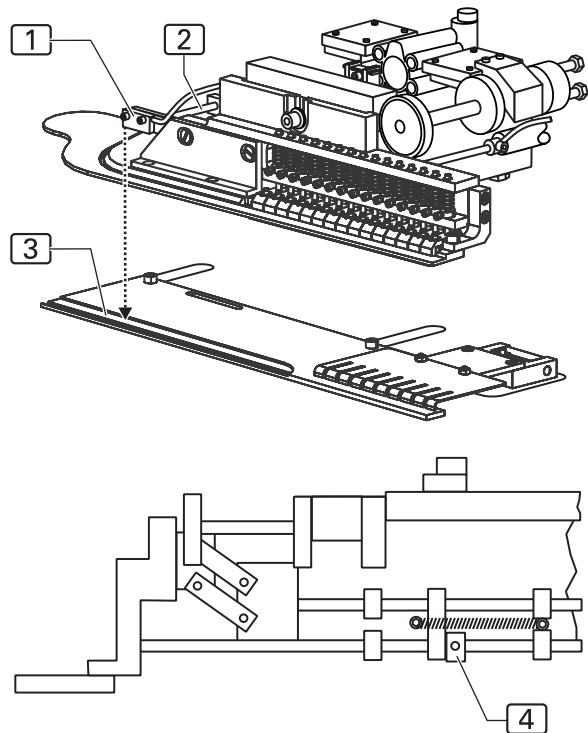

# C.5 Maintenance

## C.5.5 Machine set-up

### Safety photocell adjustment:

The safety photocell [6] prevents the sewing head from sewing beyond the groove [2] of the clamp rail [3] hinausnäht and prevents the needle from being damaged.

1. Lower main clamp.
2. Depressurize machine by disconnecting the compressed air hose of the machine from the on-site compressed air supply system.
3. Move main clamp manually under sewing head.
4. Lower needle using handwheel.
5. Position main clamp so that distance **E** between needle and end of clamp rail groove is 5 mm.
6. Set safety initiator (S20) [6] in slot of retaining rail [1] to correct position.
7. Loosen locknut and reposition safety initiator so that safety initiator LED [5] illuminates as soon as it is darkened by the main clamp retaining bracket [4]. The switching distance **S** must be 1 mm.
8. Secure position, tighten locknut.

Fig. 17

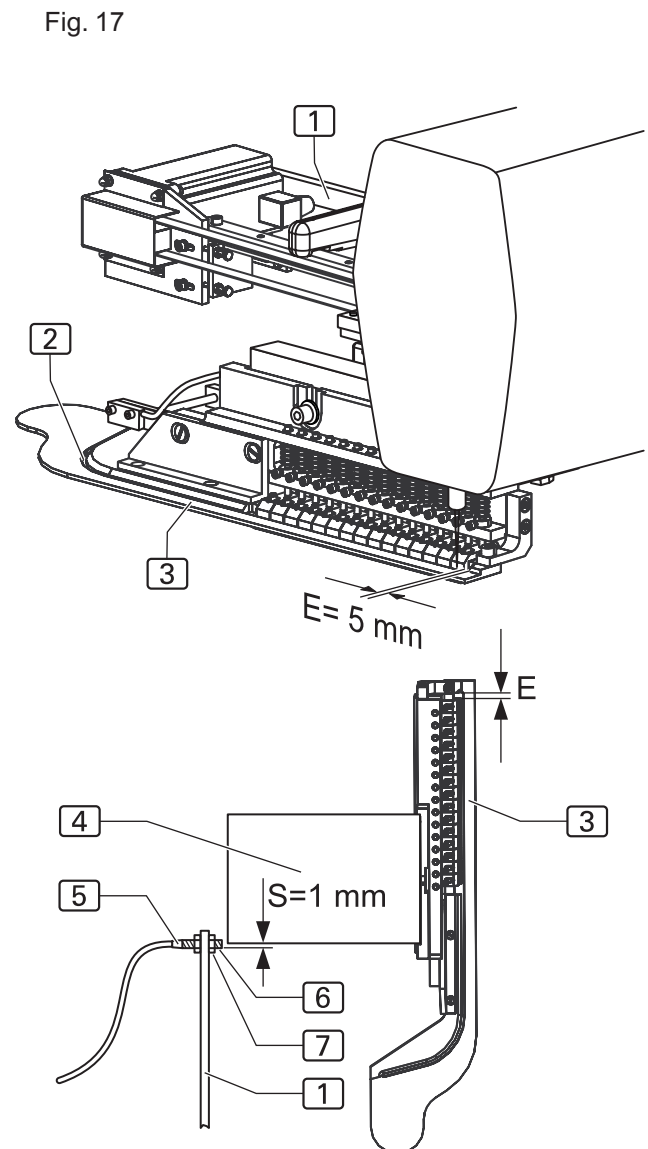



# C.5 Maintenance

## C.5.5 Machine set-up

Fig. 18

### Installation stepper motor:

The PCB for controlling the stepper motor is installed in the control box.

**NOTE - Machine cycle!**

To prevent moving machine parts from colliding with each other or with other components when the machine is switched on again, move the machine manually into its start position before the PCB is replaced.

1. Depressurize the compressed air system of the machine. Disconnect the compressed air hose of the machine from the on-site compressed air supply system.
2. Slide main clamp into start position.

**CAUTION - Damage to electrical components!**

The PCB switches must not be tampered with while voltage is applied to the machine.

Otherwise, related electrical components may be damaged or become unusable!

Disconnect machine from power supply system and protect it against accidental reconnection.

### Adjusting switches on the PCB:

1. Set step width:
  - using DIP switches [1] and [2],
  - micro step at hook switches [6] and [7].
2. Set current lowering using DIP switch [3].
3. DIP-switch [4] to ON
4. Set motor phase current, rotate switch [5] to F.
5. Switch on supply voltage. When the PCB is adjusted correctly, the LED [8] (stand-by) is illuminated, the stand-by relay is energized.

Fig. 18

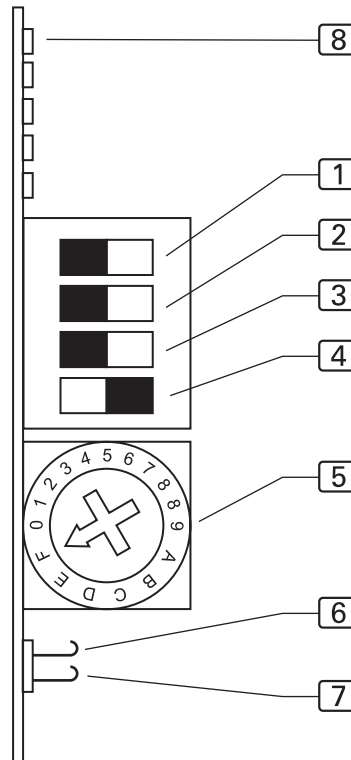

Micro step		DIP switch 1	DIP switch 2
Hook switch [6] open Signal = 0	Hook switch [7] closed Signal = 0		
Hook switch [6] closed Signal = 1	Hook switch 6 open Signal = 1		
200	2000	ON	OFF
400	4000	ON	ON
500	5000	OFF	ON
1000	100000	OFF	OFF
Signal 0 = deenergized, Signal 1 = energized			
Rotary switch position	Phase current	DIP switch 3	Current lowering
F	5,50 A	OFF	ON
		ON	OFF

# C.5 Maintenance

## C.5.5 Machine set-up

Fig. 19

### Setting the thread cutter:

The three-digit value input (GP Par. 35) determines when the thread cutter is activated.

The setting of the thread cutter must be checked during machine operation and corrected as required.

- Press **F1** key
- Press **F2** GP key
- Select global parameter 39 (turn back) and set value to 00 INC.

Store value and exit setting level:

- Press **P** key

### Checking the thread cutter:

1. Rotate sewing head handwheel in direction of machine rotation until needle reaches highest point (pinning position **C**).
2. Lock handwheel at position **C** by depressing pinning pin of hole to left of handwheel.
3. Install drive belt **1** so that shaft feather key **2** is flush with motor housing mark **3**.
4. Unlock handwheel.
5. Insert the following values in Global Parameters:
 

35: Thread lever in position up	023 INC
36: Switch-on pos. for thread cutting	110 INC

6. Start the thread cutting function:

- Press **P** key
- Press **F2** diagnostics key
- Press **F2** sewing motor key
- Press **F2** thread cutter key

Start or stop machine run:

- Press **0** key

Fig. 19

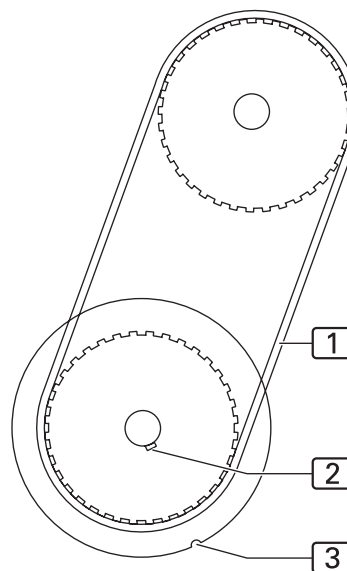

7. Check position **C** to see if shaft feather key **2** is flush with motor housing mark **3**.  
If required, change values and test thread cutting function.
8. Select global parameter 39 (turn back) and set value to 25 INC.
9. Start thread cutting and recheck positions.

# C.5 Maintenance

## C.5.5 Machine set-up

## Fig. 22

### Checking the rest thread monitor:

The rest thread monitor is checked using a photocell. If the messages on the display do not match the filling state of the bobbin, the photocell sensitivity must be checked.

1. Fill bobbin to half its capacity so that filling state indicators **2** of upper chamber **1** are covered.
2. Insert bobbin and sew until display shows: SPOOL: 003 m.  
Keep sewing until display shows: SPOOL EMPTY
3. Remove bobbin, unwind rest thread and measure remaining length (should be 0.5 m).

### Adjusting the photocell:

- If the thread on the bobbin is sewn off over the rest length of 0.5 m without the message SPOOL EMPTY being displayed, the photocell sensitivity must be increased:
  - Rotate potentiometer at photocell in clockwise direction.
- If the message SPOOL EMPTY is displayed even though the bobbin contains more than 0.5 m thread, the photocell sensitivity must be reduced:
  - Rotate potentiometer at photocell in counter-clockwise direction.

Fig. 20

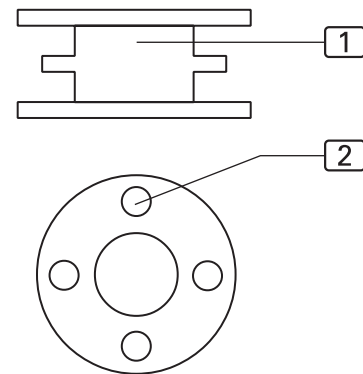

# C.6 Troubleshooting

Error 01: „Sewing program empty“	Current sewing program empty; possibly distances and routes have not been input or the entire program was erased	Insert program values manually, copy from other program or retrieve from ROM (parameter INIT)
Error 02 : „Seam not enabled“	Current sewing program not activated; number appears black on white	Press <ENT> key to activate program
Error 04 : „Clamp in wrong position“	Real value pulse from clamp motor does not correspond with nominal value	Reduce current for clamp motor to MAX clamping pressure
Error 05 : „I/O communication error“	Error transmitted between control unit and I/O module	Check connecting cable; if OK, replace control unit and/or I/O module
Error 06 : „Position not valid“	Clamp slide not positioned correctly	Check sensor connection to clamp motor; check connecting cable between adapter board 9020020 and I/O module 9020013; replace adapter board 9020020
Error 07: „No pulses from clamp motor“	No position pulse from clamp motor. If the clamp motor moved slightly, the pulses could not be processed properly. If the motor did not move, problem may be caused by control unit or clamp motor power unit	Check connection to clamp motor; replace clamp motor; replace adapter board 9020020; check condition of LEDs at power board (Berger); if required, check Berger motor; check connection to clamp motor (plug); check connection between 9020020 and power unit (plug); replace adapter board 9020020
Error 08: „Main clamp at the stopper“	Limit switch ES04 switched during clamp movement even though clamp should have been distant still	Check distance counter using test program (steps); if counter is faulty, replace clamp motor or adapter board 9020020; if counter is OK, check switch 04
Error 09: „Clamp can not leave the switch“	Clamp slide moves to limit switch during initialization but does not return (direction not reversed)	Using test program 'Clamp motor actuation', enter slow speed and reverse direction using arrow keys; if motor does not reverse direction, check: connection between 9020020 and power unit (plug); Berger power unit; if motor reverses direction, check limit switch ES04
Error 12: „Safety photocell not lighted“	No reflection for FZ 20 (safety)	Replace reflective film; check photocell (input)

# C.6 Troubleshooting

Error 13: „Clamp position error“	Excessive difference between nominal position (step motor default) and actual position (pulse from incremental sensor) of clamp slide; clamp slide probably blocked	Remove blocked component; check clamp slide for easy movement; check motor pinion (may be loose on shaft); tension transport belt
Error 14: „Insertion/sewing length error“	Sewing length exceeds maximum possible sewing distance; excessive insertion distance	Program sewing distance / insertion distance correctly
Error 15: „Switch for curve start“	ES12 (curve start slope) does not switch or switches too late	Check ES12 (input); check mechanical components for easy movement
Error 16: „Folder not left“	ES08 (folder at left stop) does not switch or switches too late	Check ES08 (input); check mechanical components for easy movement
Error 21: „Folder not sideways“	ES05 (clamp movement sideways) does not switch or switches too late	Check ES05 (input); check mechanical components for easy movement
Error 22: „Clamp/curve wrong“	Clamp does not correspond with curve	Clamp safety switch (ES15/16) not identical with curve safety switch (ES13/14)
Error 29: „No pulses from sewing motor“	No pulse from sewing motor after sewing process starts (sewing motor does not run)	Check sewing motor and synchronization; check connection between I/O module 9020013 and sewing motor; read both upper LEDs at 9020013: left LED illuminates briefly when needle up; right LED shows synchronization pulses (512 pulses/rotation); if no LED illuminates when handwheel is actuated, check sewing motor power supply and replace sewing motor, if required. If LEDs are OK and motor does not run before error messages, check connection between 9020020 and sewing motor, replace 9020020 or sewing motor, if required; if motor makes some stitches before error message, check connection between control unit and I/O module, replace components as required
Error 30: „Sewing motor too fast“	During thread cutting, sewing motor did not reach cutting speed within error period	Replace sewing motor or synchronizer

# C.6 Troubleshooting

Error 32: „Thread position does not come“	During thread cutting, sewing motor did not reach cutting position	Input slower cutting speed and earlier cutting position; replace sewing motor or synchronizer
Error 33: „Sewing motor does not stop“	After thread cutting, sewing motor does not stop within error period	Input slower cutting speed and earlier cutting position; replace sewing motor or synchronizer
Error 34: „Needle not up“	Needle not in upper rest position; when the error message is issued, the control unit attempts once more to move the needle to the upper position	Check sewing motor and synchronizer; check connection between 9020013 and sewing motor; read condition of two upper LEDs at 9020013: if no LED illuminates when handwheel is rotated, check sewing motor power supply; replace sewing motor if required; if LEDs are OK, check connection between 9020020 and sewing motor; replace 9020020 if required
Error 35: „Thread breakage“	Thread monitor detects thread breakage	
Error 37: „Thread only rest“	The photocell at the spool case is illuminated, spool empty	If spool is not empty, the photocell is maladjusted (response too sensible); adjust correctly
Error 41: „No parts“	Photocell FZ21 remains illuminated during insertion	Adjust photocell sensibility; input test 21
Error 42: „Photocell not lighted“	Photocell FZ21 does not detect end of seam	Sewing distance too long; adjust photocell sensibility; input test 21
Error 43: „Photocell lighted too early“	Photocell FZ21 detects intermittent reflection during insertion	Adjust photocell sensibility; input test 21
Error 45 ... 48: „I/O DAC, ULN, 485, RES“	Internal hardware error during data transmission to adapter board 9020020	Replace 9020020

# C.7 Specifications

## Power supply

Supply voltage	230 V $\pm$ 10 %, 50/60 Hz
Connection to supply	(1, N, PE) AC
Power consumption	1.3 kW
Fusing	16 A

## Dimensions of the machine

Width x Depth x Height in mm	12500 x 1050 x 1640
------------------------------	---------------------

## Table height

Adjustable height in mm	790-1240
-------------------------	----------

## Weight

Overall weight	approx 190 kg
----------------	---------------

## Compressed air

Operating pressure	6 bar
Quality	oil-free
Air consumption	16 NL

## Vacuum

Displacement (minimum)	130 m <sup>3</sup> /h
------------------------	-----------------------

# **Section D** **Programming Instructions**



# Section D

## Programming Instructions

### Contents

<b>D.1 Operating panel .....</b>	<b>59</b>
D.1.1 Display and key functions.....	59
<b>D.2 Fundamentals of programming.....</b>	<b>60</b>
D.2.1 Program control layout .....	60
D.2.2 Program level overview .....	62
<b>D.3 Programming .....</b>	<b>63</b>
D.3.1 System menu .....	63
Entering the service code: .....	63
Displaying total piece counter: .....	63
Eprom seam parameters: .....	64
Setting the seam sequence: .....	64
Copying seam numbers: .....	64
Erasing seams: .....	64
Entering seam names: .....	65
Copying sewing programs to the memory stick .....	65
Loading sewing programs from the memory stick .....	65
Copying variables to the memory stick.....	66
Loading variables from the memory stick .....	66
Running clamp motor in permanent test .....	66
Testing the thread cutter .....	66
D.3.2 Service menu start level .....	67
Request service menu level 1 .....	69
Photocell correction for sewing piece pick-up,Class 1931-5. ....	67
Changing the fixed end of seam point,class 1931-5 .....	67
Manual actuation of the thread clamp .....	68
Filling bobbin .....	68
Resetting the insertion process .....	68
D.3.3 Service menu level 1 .....	69
Setting the seam sequence .....	69
Resetting the day counter to zero.....	69
Manual winding .....	70
Selecting machine control inputs / outputs .....	70
D.3.4 Global parameters .....	73
Requesting / exiting the global parameter menu.....	73
D.3.5 List of special parameters .....	75
Request / exit special parameter menu: .....	75
D.3.6 Level 2 special parameters / Functions .....	77
Enabling / disabling functions: .....	77
D.3.7 Level 3 special parameters / Functions .....	78
Switching photocell for beginning of seam on or off: .....	78
Switching photocell for end of seam on or off: .....	78

# Section D Programming Instructions

## Contents

D.3.8	Level 4 special parameters / Functions .....	78
	Switching vacuum supply on or off: .....	78
	Switching sewing to fixed end of seam point on or off: .....	78
D.3.9	Level 5 special parameters / Functions .....	79
	Switching the top thread monitor on or off.....	79
	Switching the rest thread monitor or bottom thread monitor on or off .....	79
	Switching clamp position after end of seam on or off.....	79
	Moving clamp to waiting position .....	79
D.3.10	Level 2 special parameters / Lists .....	80
	Selecting modes .....	80
	Setting upper part parameters .....	81
	Setting stitch lengths and bar tacks .....	81
	Parameters for clamp transport .....	81
<b>D.4</b>	<b>Factory settings .....</b>	<b>82</b>
	M 01 global parameters 1931-5 .....	82
	M 01 special parameters 1931-5 .....	83
	M 01 special parameters 1931-5 .....	84

# D.1 Operating panel

## D.1.1 Display and key functions



Fig. 1

- 1 Display  
During machine operation, the display shows the values of the selected sewing program. If menus are activated, the menu symbol or the corresponding parameters of the function are displayed.
- 2 Numeric keypad  
All variable number values are entered using the numeric keypad.  
The desired sewing programs are requested using the M key. The P key is used to request submenu, to confirm input and to exit the programming mode.
- 3 Slot for memory stick  
The memory stick is the storage medium for backup copies of all program control data. Programs can be copied to and stored on the memory stick and loaded into the machine control unit if required.
- 4 All arrow keys  
Pressing the UP or DOWN arrow key will move the cursor one line up or down in the selected menu.  
Pressing the LEFT or RIGHT arrow key will either mark the desired parameter in the selected menu or, if the parameter list comprises several pages, browse forward or backward.
- 5 Symbol bar  
The symbol bar indicates the menus that can be requested directly from the start level using the function keys 7.  
For all other menus, the corresponding symbols are shown on the operating panel display.
- 6 Key Program STOP  
If the switch is pressed during machine operation, all machine movements and the sewing process are stopped.

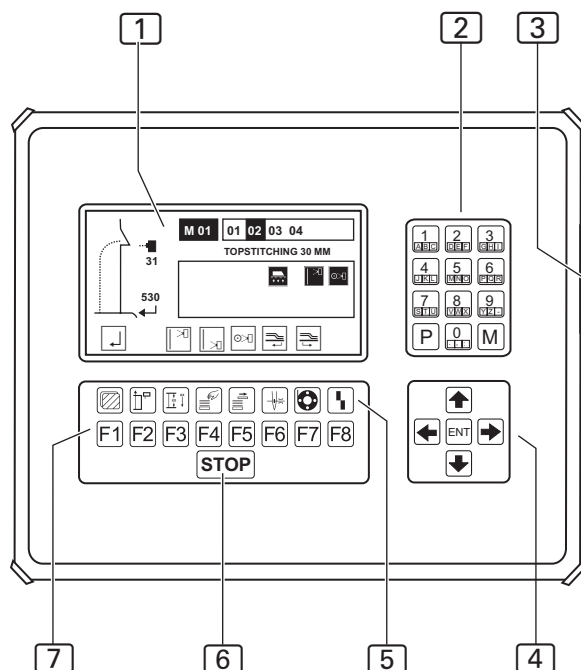
Fig. 1



- 7 The function keys are used to request the menus on the selected level for setting or changing machine functions.  
Two function keys have an identical function in all selectable menus.  
To move to the previous level or to the start level and to move to the next level:

Press  or  key.

# D.2 Fundamentals of programming

## D.2.1 Program control layout

The program control is controlled using four different kinds of menus:

1. System menu,
2. Service menu,
3. Global parameter menu,
4. Special parameter menu.

### System menu

The system menu is used to perform all settings for the program control operating system and for managing the sewing programs:

- Copying factory settings to the program control unit,
- Saving programmed sewing programs to the memory stick,
- Copying and renaming sewing programs,
- Copying sewing programs from the memory stick to the program control unit.

### Service menu

The service menu is used to directly request service functions. These functions support machine set-up or other works required during machine operation, e.g. resetting the day counter or winding the bottom thread.

### Global parameter menu

This menu is used exclusively for setting the global parameters, i.e. parameters that control the basic functions of the machine. Changing global parameters will result in changes of seams of all stored sewing programs (e.g. time for blowing off a finished sewing piece using compressed air).

### Special parameter menu

Special parameters are settings that refer only to one particular seam of a sewing program. Changing a special parameter will affect only the currently selected seam for which a setting is made (e.g. stitch length of a seam). The special parameter menu consists of several submenus.

Special parameters can be functions that are enabled or disabled as required or parameter values that are set in lists.

### Sewing program

A sewing program controls the entire machine operation during production:

- transport of the sewing piece to the sewing head,
- tucking of a seam and
- ejection of the sewing piece.

A sewing program is determined by two different kinds of values:

- global parameters,
- special parameters.

Sewing programs can be copied or renamed.

### Seam number

Each sewing program can be executed with up to six seams of different stitch widths. The seams are assigned to the sewing program by seam numbers (01, 02, .... 06). The numeric string of the two-digit seam number is freely selectable.

### Combination sewing program with seam

A sewing program can be combined with one seam, with several seams or with all four seams.

If a sewing program with several seam numbers is requested, the seams are effected in the sequence of the seam numbers from left to right.

The sequence of the seam number is freely selectable.

### Memory

Sewing programs are stored in the memory (**M**).

The program control memory can contain up to 50 sewing programs (**M 01-M 50**) with up to six seams (**01, 02, 03, 04, 05, 06**) each.

All sewing programs stored in the memory can be copied to the memory stick (backup copies).

### Creating sewing programs

Basically, it is possible to create entirely new sewing programs; however, it is easier to:

- copy a factory-programmed sewing program to an unused location in the memory and to modify this program,
- copy an already modified sewing program to an unused location in the memory and to adapt it further in accordance with the intended purpose.

# D.2 Fundamentals of programming

## D.2.1 Program control layout

Fig. 2

### Setting seam number using handwheel

**Fig. 02:** The handwheel 1 of the clamp must be set to the number of the seam that is to be effected first, i.e. the left number in the line of seam numbers displayed.

### Factory setting

The machine comes with a factory-installed standard program (M 01) with four seams (01, 02, 03, 04) of different stitch widths.

**Tab. 01:** The numbers on the handwheel are assigned to the seam numbers.

### Access to menus

The following menus are freely accessible:

- Service menu,
- Global parameter menu,
- Special parameter menu.

Except for three submenu pages, the entire system menu is controlled by access privileges. These privileges protect the system menu from unauthorized access. Data cannot be entered and the system menu cannot be modified unless the service code has been entered. This code is contained in the documentation delivered with the machine.

### Menu level structure

The program control is divided into six menu levels (start level and levels 1-5).

The **system menu** is requested from the start level. The remaining operator prompting is achieved with plain text in the submenus.

The **service menus** are requested directly from the start level and from level 1.

The **global parameter menu** is requested from level 1, the parameters pertaining to the menu are selected and changed in a list.

The **special parameter menu** is requested from level 1 and is edited in four other levels (levels 2-5) and in the pertaining parameter lists.

**! CAUTION - Damage to machine!**

**Some of the menu entries start machine units or a machine cycle.**

**This may damage machine components if the machine is not ready for operation.**

**Do not enter data unless the machine is ready for operation.**

Fig. 2

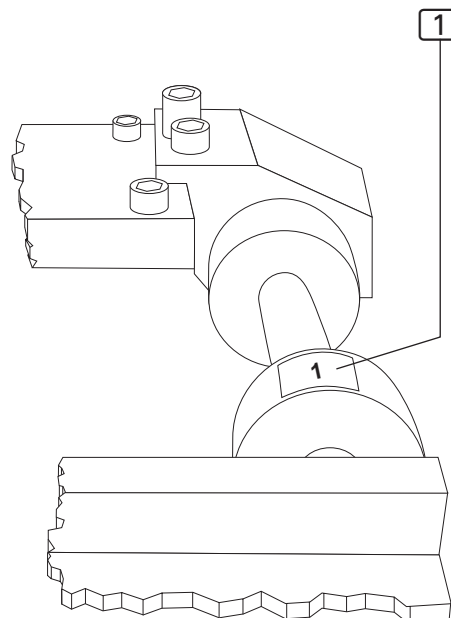

Seam number assignment on handwheel		
Handwheel	Seam number	Stitch width
1	01	30 mm
2	02	32 mm
3	03	35 mm
4	04	37 mm

# D.2 Fundamentals of programming

## D.2.2 Program level overview

Fig. 3

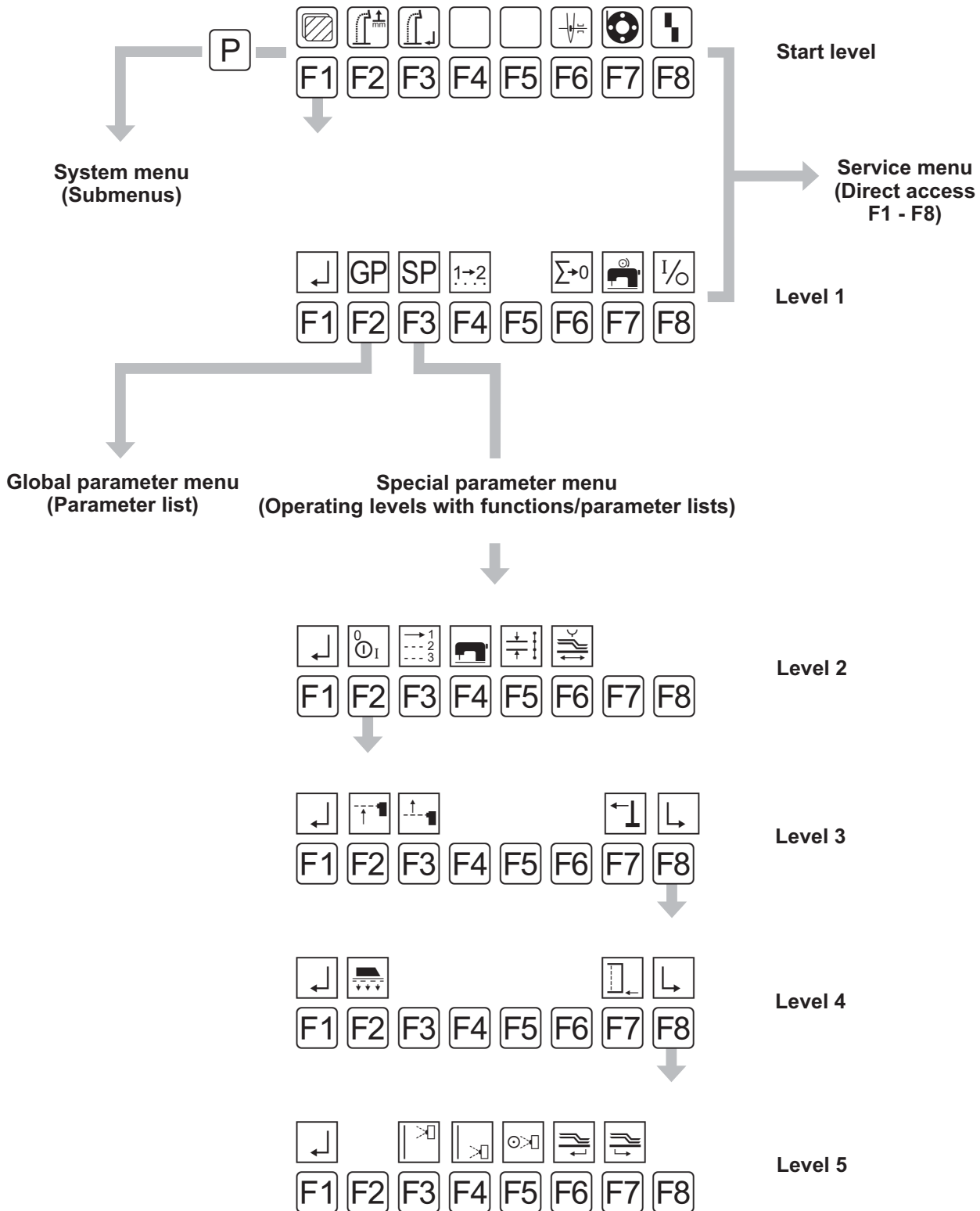

# D.3 Programming

## D.3.1 System menu

The system menu is divided into several submenus. The submenus themselves are divided into access-protected and open submenus. Access is protected by the **service code**.

### Open submenus

Open submenus are freely accessible from the start menu:

- Enter service code
- Display total piece counter

### Access-protected submenus

Access-protected submenus can only be opened after the service code has been entered:

- Eprom seam parameters
- Copy seam numbers
- Erase seam
- Enter seam name
- Copy sewing program to memory stick
- Load sewing program from memory stick
- Copy variables (global parameters/special parameters) to memory stick
- Load variables (global parameters/special parameters) from memory stick
- Run clamp motor in permanent test
- Test stacker

### NOTE - System menu control!

The submenus of the system menu are requested and exited using the same keys. Exceptions from this rule are indicated by plain text in the corresponding menu.

Request the system menu from the start level:

- Press **P** key.

Confirm input and exit the system menu:

- Press **P** key.

### NOTE - Submenu levels!

All input for the system menus must be started from the submenu level 1.

To change to the submenu level 1:

- Press  key.

The submenus of the system menu can be requested using either the arrow keys or the function keys.

### NOTE - RESET!

As a rule, a RESET should be performed in the system menu after settings have been changed to reset the machine to its start position.

- Press key **STOP** twice.

### ■ Entering the service code:

Entering the service code allows access to the access-protected submenus of the system menu.

- Press **P** key.
- Press **F3** key (service code).
- Enter service code numbers using the numeric keypad. The code is: 50190
- Press **P** key to confirm input.

### ■ Displaying total piece counter:

With this counter, the total number of finished pieces can be displayed. The counter cannot be reset.

- Press **P** key.
- Press **F4** key (additional programs).
- Press **F3** key (piece counter).

The number of pieces : 0000000 is displayed.

# D.3 Programming

## D.3.1 System menu

### ■ Eprom seam parameters:

Use this function to copy the factory-programmed fixed seams from the Eprom back to the sewing program.

- Press **P** key.
- Press **F1** key (init parameters).
- Press **F4** key (Eprom seam parameters).
- Enter seam number 01 using numeric keypad.

### ■ Setting the seam sequence:

The setting refers to the selected sewing program. The sequence for sewing the seams can be freely selected. When the sequence is set, existing seam numbers are overwritten or new seam numbers are written



- Press **F1** key.
- Press **F4** key.

The display shows the marking of the sewing program and the seam numbers.

**20** **01** 02 03 04

Mark seam number to be changed using cursor:

**20** 01 **02** 03 04

Open "Overwrite" function:

- Press **ENT** key.

Enter new seam number using numeric keypad:

**20** 01 **04** 03 04

Confirm input and exit menu:

- Press **P** key.

The display shows the new seam sequence.

**20** **01** 03 04

### ■ Copying seam numbers:

Use this function to copy the properties of a factory-programmed sewing program or of your self-configured sewing programs into other sewing programs.

During the copying process, all seams of a sewing program are transferred so that the existing properties of a sewing program will be overwritten completely.

1. Request sewing program (destination) and mark desired seam number (source).

- Press **M** key.
- 2. Enter two-digit seam number using numeric keypad.
- Press **P** key.
- Press **F1** key (init parameters).
- Press **F3** key (copy seam number).
- Enter two-digit seam number using numeric keypad.

The display shows \*O.K. PLEASE WAIT\* to indicate that the copy process has been successfully completed.

### ■ Erasing seams:

Request sewing program and mark seam number to be erased using cursor (seam number is underlaid black).

- Press **←** or **→** key
- Press **P** key.
- Press **F1** key (init parameters).
- Press **F5** key (erase seam).



# D.3 Programming

## D.3.1 System menu

- Enter seam number using numeric keypad.
- Confirm safety prompt, press **ENT** key.

### NOTE - Deleting seam numbers

If a seam number is deleted, it is removed from all sewing programs into which it had been inserted!

### ■ Entering seam names:

A sewing program can be named using plain text.

Request sewing program.

- Press **P** key.
- Press **F1** key (init parameters).
- Press **F1** key (enter seam name).
- Use the numeric keypad to enter numbers or text. To enter letters, hold the required color-coded function key depressed and press the corresponding color-coded number key for the letter on the numeric keypad. To enter blanks between text or number combinations, press the LEFT or RIGHT arrow key.

Buchstabe löschen:

- Press **9** key four times.

Confirm input, exit menu:

- Press **P** key.

### ■ Copying sewing programs to the memory stick

Programmed sewing programs can be copied to the memory stick (back-up copies).

Select sewing program.

- Insert memory stick into USB slot.
- Press **P** key.
- Press **F1** key (init parameters).
- Press **F6** Machine <--> Stick.
- Press **F1** Active seam --> Memory stick.
- Enter seam number using numeric keypad.

### ■ Loading sewing programs from the memory stick

To reestablish or to change seams, sewing programs can be loaded from the memory stick by overwriting an existing location or selecting an unused location.

- Insert memory stick into USB slot.
- Press **P** key.
- Press **F1** key (init parameters).
- Press **F6** Machine <--> Stick.
- Press **F2** key Stick --> Active seam.
- Enter sewing program and seam number using numeric keypad.

# D.3 Programming

## D.3.1 System menu

### ■ Copying variables to the memory stick

All variables (global parameters/special parameters) can be stored on the memory stick (backup copies).

- Insert memory stick into USB slot.
- Press **P** key.
- Press **F1** key (init parameters).
- Press **F6** Machine <--> Stick.
- Press **F3** key Machine memory--> Stick.

Confirm safety prompt.

- Press **ENT** key.

### ■ Loading variables from the memory stick

All variables (global parameters/special parameters) can be downloaded from the memory stick to the program control memory to reestablish the machine configuration.

- Insert memory stick into USB slot.
- Press **P** key.
- Press **F1** key (init parameters).
- Press **F6** Machine <--> Stick.
- Press **F4** key Stick --> Machine memory.

Confirm safety prompt.

- Press **ENT** key.

### NOTE - Current configuration!

If this function is used to download all variables from the memory stick to the program control, all current sewing programs will be overwritten.

### ■ Running clamp motor in permanent test

The clamp motor can be run permanently to check for constant machine movement.

- Press **P** key.
- Press **F2** key (diagnostics).
- Press **F3** key (clamp transport).
- Press **F2** key (clamp motor permanent test).

Confirm safety prompt.

- Press **ENT** key.

The clamp motor runs permanently until it is stopped. To stop the motor:

- Press key **STOP**.

### ■ Testing the thread cutter

By entering a three-digit value global parameter 35, you can determine when the thread cutter is activated. The input must be checked for a machine cycle and corrected if required.

- Press **P** key.
- Press **F2** key (diagnostics).
- Press **F2** key (sewing motor).
- Press **F2** key (thread cutter).
- Enter value using numeric keypad.

Start or stop machine cycle.

- Press **0** key.

# D.3 Programming

## D.3.2 Service menu start level

The service functions of the service menu are requested by direct access from the start level or from level 1. Service functions support the working process during machine production.

### Functions on the start level

The function keys on the start level are assigned to the symbols below them. These symbols cannot be changed; they are always visible.



- F1 Request service menu level 1
- F2 Photocell correction for sewing piece pick-up, Class 1931-5.
- F3 Change fixed seam end point, Class 1931-5  
Photocell correction for end of seam, Class 1931-5
- F6 Actuate thread clamp manually
- F7 Load full bobbin
- F8 Reset insertion process

### ■ Request service menu level 1:



- Press **F1** key.

### ■ Photocell correction for sewing piece pick-up, Class 1931-5.

This setting refers to the selected seam. Depending on the machine class, the beginning of the seam is determined using different methods.

**Class 1931-5:** The beginning of the seam is determined by the scanning spot for sewing piece pick-up of the photocell. Therefore, the setting refers to a photocell correction.



- Press **F2** key.

The cursor automatically marks the changeable value. To change this value gradually:

- Press  or  key.

To enter a completely new numeric value:

- Enter numbers using numeric keypad.

Confirm input and exit menu:

- Press **P** key.

### NOTE - Check settings!

The settings must be checked using a sewing piece; if required, they must be corrected.

### ■ Changing the fixed end of seam point, class 1931-5

The setting refers to the marked seam.

Depending on the machine class, the end of the seam is determined using different methods.

**Class 1931-5:** The end of the seam is determined in relation to the position of the guide laser. The sewing piece is aligned to the guide laser. The setting refers to a fixed sewing distance.



- Press **F3** key.

The cursor automatically marks the changeable value. To change this value gradually:

- Press  or  key.

To enter a completely new numeric value:

- Enter numbers using numeric keypad.

Confirm input and exit menu:

- Press **P** key.

# D.3 Programming

## D.3.2 Service menu start level



### NOTE - Check settings!

The settings must be checked using a sewing piece; if required, they must be corrected.

#### ■ Manual actuation of the thread clamp

After the top thread has been passed through the needle, the thread clamp is actuated manually to protect the top thread from being pulled out of the needle when a machine cycle starts.



- Press **F6** key.

#### ■ Filling bobbin

Insert thread and fill bobbin:



- Press **F7** key.



- Press **F8** key.

Acknowledge status messages on display:

If the message SPOOL EMPTY is displayed, insert a full bobbin and

- Press **ENT** key.

If the message SPOOL: 004 M is displayed when a full bobbin is inserted



- Press **F7** key.



- Press **F8** key.



### NOTE - Rest thread monitor sensitivity!

If the bobbin is empty and the display does not show a status message, the photocell sensitivity must be adjusted (see Section C, Service Instructions).

#### ■ Resetting the insertion process

This function depends on the mode of machine operation. It refers only to machine movements that can be performed before the automatic operation.

The machine movements will be reset to start position.



- Press **F8** key (several times if required).

# D.3 Programming

## D.3.3 Service menu level 1

### Functions on level 1

The function keys on the level 1 are assigned to the symbols above them as shown on the display.

The settings of the global parameter menu (GP) and of the special parameter menu (SP) which can also be requested from this level are described in separate sections.



- F1 Back to start level
- F2 Request global parameter menu
- F3 Request special parameter menu
- F4 Set seam sequence
- F6 Reset day counter to zero
- F7 Manual winding
- F8 Select machine control inputs / outputs

### ■ Setting the seam sequence

The setting refers to the selected sewing program. The sequence for sewing the seams can be freely selected. When the sequence is set, existing seam numbers are overwritten or new seam numbers are written



- Press **F1** key.



- Press **F4** key.

The display shows the marking of the sewing program and the seam numbers.

**01** 01 02 03 04

Mark seam number to be changed using cursor:

**01** 01 **02** 03 04

Open "Overwrite" function:

- Press **ENT** key.

Enter new seam number using numeric keypad:

**01** 01 **04** 03 04

Confirm input and exit menu:

- Press **P** key.

The display shows the new seam sequence.

**01** **01** 03 04

Erase seam number:

- Mark seam number using cursor, then erase:
- Press **M** (erase) key.

Confirm input, exit menu:

- Press **P** key.

### 👉 NOTE - Seam sequences!

Just as the sequence of the seams may be selected as desired, a seam can be written into a sewing programs once or several times. A sewing program can consist of up to 6 seams.

### ■ Resetting the day counter to zero

This function is used to reset the day counter for a production cycle to zero.



- Press **F1** key.



- Press **F6** key.

The display counter is now reset to zero.

Display: PART: 0000

# D.3 Programming

## D.3.3 Service menu level 1

### ■ Manual winding

This function is used to wind thread from the thread bobbin to the bottom thread bobbin. To start the function:



- Press **F1** key.



- Press **F7** key.

- To exit, press any key.

### 👉 NOTE - Remove top thread!

The top thread must be removed up to the thread lever to protect the top thread and the bottom thread from being entangled.

### ■ Selecting machine control inputs / outputs

This menu is used for troubleshooting and for a manual testing of machine operation settings.

The outputs (OUT) can be selected and tested separately. The corresponding inputs (INP) are displayed for an active output. Additionally, the selected output can be switched intermittently.

Activated inputs/outputs are marked with highlighted numbers.

01	02	03	04	05	06	07	08	09	10
11	12	13	14	<b>15</b>	16	17	18	19	20
21	22	23	24	25	26	27	28	29	30
31	32	33	34	35	36	37	38	39	40
41	42	43	44	45	46	47	48	49	50
51	52	53	54	55	56	57	58	59	60

### 👉 NOTE - Machine movements!

If outputs are activated, the machine performs the corresponding functions. Before activating the outputs, remove all unnecessary objects within the operating range of the machine.

Select output:



- Press **F1** key.



- Press **F8** key.

Select number line:

- Press  or  key.

Mark output number by moving the corresponding function number using the cursor. The cursor now has the shape of an arrow.

- Press  or  key.

Activate output:

- Press **ENT** key.

The function number is highlighted in black. The output is active.

Deactivate output:

- Press **ENT** key.

Switch output to intermittent operation:

- Mark function number using cursor.
- Press **ENT** key for approx 3 seconds.

The function number is highlighted in black and flashes. The output is active intermittently.

Switch off intermittent operation of output:

- Press **ENT** key.

The function number is highlighted in black again. The output is still active.

Deactivate output:

- Press **ENT** key.

# D.3 Programming

## D.3.3 Service menu level 1

Outputs						
Valve	Output number			Cylinder number	Signal output	Valve type
Y01	01	Open / close clamp		01	X07 Pin02	3/2 way
Y02	02	Move clamp in / out sideways		02	X07 Pin03	5/2 way
Y10	10	Thread clamp forward / rearward		10	X07 Pin06	5/2 way
Y11	10	Blow thread in, synchronous with Y10		10	X07 Pin06	5/2 way
Y15	15	Vacuum on / off		15	X07 Pin01	5/2 way
Y20	20	Fabric clamp forward / rearward		20	X07 Pin08	5/2 way
Y21	21	Fabric clamp open / close		21	X07 Pin09	5/2 way
Y26	26	Clamp downholder up / down		26	X11 Pin30	5/2 way
Y28	28	Tissue stop forward / rearward		28	X07 Pin10	5/2 way
Y30	30	Thread cutter		01	X11 Pin18	5/2 way
Y31	31	Rest thread monitor		31	X07 Pin05	5/2 way
Y36	36	Thread tension blowing		36	X07 Pin04	3/2 way
Y47	47	Blow pieces off			X07 Pin07	3/2 way
Y49	49	Holding stamp up / down		49	X11 Pin26	5/2 way
Y54	54	Zipper channel		54	X11 Pin22	5/2 way
Y55	55	Roller stitch width		55	X11 Pin23	3/2 way

Inputs 1931-5						
Switch	Input number		Switch type		Signal input	
S01	01	Start switch	Footswitch	Make	X09 Pin01	
S04	04	Clamp reference point	Initiator NPN	Break	X09 Pin04	
S05	05	Move clamp sideways	Initiator NPN	Make	X09 Pin05	
S11	11	Curve start clamp	Initiator NPN	Make	X09 Pin11	
S12	12	Curve start slope	Initiator NPN	Make	X09 Pin12	
S19		Sewing drive needle up	Initiator NPN	Make	Plug Efka	
S20	20	Safety photocell	Initiator NPN	Make	X13 Pin20	
S21	21	Slash length photocell / scanning	Photocell NPN		X13 Pin21	
S23	23	Top thread monitor	Probe		*Plug X2	
S25	25	Bobbin rest thread monitor (lock stitch)	Photocell NPN		X13 Pin25	

# D.3 Programming

## D.3.3 Service menu level 1

Terminal assignment for lock stitch (1-4):  
S23 \*Top thread monitor

Terminal assignment \*plug X2:

yellow 1  
green 2  
white 3  
brown 4

1	2	3	4	5	6	7	8



# D.3 Programming

## D.3.4 Global parameters

**Global parameters** are values that control the basic functions of the machine. If global parameters are changed, this change affects all stored sewing programs.



### ■ Requesting / exiting the global parameter menu

The minimum and maximum input values are limited by the program control unit. Values that are not within the limits will not be accepted but reduced to the corresponding minimum or maximum value.

Change from start level to level 1:



- Press **F1** key.

Request global parameter menu:



- Press **F2** key.

Browse through list:

- Press **←** or **→** key.

Move to line in list:

- Press **↑** or **↓** key.

Change parameters:

- Press **ENT** key.
- Insert new value using numeric keypad or
- Press **←** or **→** key.

Confirm input:

- Press **ENT** key.

Exit menu and save changed parameters:

- Press **P** key.

# D.3 Programming

## D.3.4 Global parameters

No.	Programmable global parameters (F2)
01	CLAMP FWD TO PART: Scanning and piece pick-up after clamp movement forward / time interval
02	TILL CLAMP DOWN .....: Lower clamp after clamp movement forward for piece pick-up / time interval
03	TILL VACUUM OFF .....: Vacuum off after clamp down / time interval
04	THREAD LENGTH: Load bobbin full
05	TILL CLAMP INSERTING: Clamp insertion delay / time delay
06	SEWING END ->CL.SIDEW.: Clamp movement rearward sideways after sewing drive off / time interval
07	TIME AFTER CLAMP OPEN: Clamp movement right to programmed position after clamp up / time interval
17	TILL TENSION OPEN .....: Tension blowing on after end of seam / time interval
18	DURATION OF TENS. OPEN: ON duration for tension blowing
19	TILL THREAD CLAMP FORW.: Time until thread clamp forward and blowing on after clamp up / time interval
20	DUR.THREAD CLAMP FORW.: Duration of blowing and thread clamp forward
25	TILL FABRIC CLAMP FORW.: Time until the fabric clamp move forward and lowers
28	TILL FABRIC CLAMP OPEN: Time until fabric clamp opens and move back
29	TILL SWING RETAINER DWN.: Lower ejector stamp after end of sem / time interval
30	TILL RETAINER SWINGS: Retract ejector stamp after stamp is lowered / time interval
31	DUR.OF PULLING RETAINER: Retract ejector stamp and raise stamp / duration
32	BLOW OUT THE PART .....: Blow off sewing pieces / duration
33	CLAMP MOVES TO STACKER: Transportation of the sewing pieces / duration
35	THREAD CATCH. "UP" POS: Thread lever in top position / duration
36	SWITCH ON POS. OF TRIMM.: Switch-on position for thread cutting: Input value of 01-255
37	TRIMMING SPEED .....: Speed during thread cutting
38	DURATION OF TRIMMING: ON duration for thread cutting
39	THREAD CATCH. TURNS BACK: Thread lever reversing angle
40	PROCESS IN STEPS .....: Gradual machine cycle

# D.3 Programming

## D.3.5 List of special parameters

**Special parameters** are values that refer to only one specific sewing program. Changes of these values affect only the currently selected sewing program for which the setting is made.

Special parameters are edited in four different levels (level 2 to level 5).

Special parameters can be functions that may be enabled or disabled or parameter values that are set in lists.



### ■ Request / exit special parameter menu:

Select sewing program and change from start level to level 1:



- Press **F1** key

Request special parameter menu:



- Press **F3** key and request submenu.

Exit menu:

- Press **P** key.

No.	Programmable special parameters in list (F3)
01	CLAMP POSITION RIGHT: Clamp position right during piece transfer (must be programmed for 1931-5)
02	TILL GUIDE TO WORK POS. Distance to move to stop point
03	INSERT SPEED .....: Clamp insertion speed
04	CLAMP SPEED .....: Clamp transport speed
05	DISTANCE TILL SEWING Distance moved till sewing starts
06	SEWING SPEED 1 .....: Sewing speed 1 (beginning of seam)
07	SEWING SPEED 2 .....: Sewing speed 2 (main seam)
08	SEWING SPEED 3 .....: Sewing speed 3 (end of seam)
09	DISTANCE SEWING SPEED 1 Distance for slow sewing (sewing speed 1)
10	DISTANCE SEWING SPEED 3 Distance for slow sewing at end of seam (sewing speed 3)
12	THREAD MONITOR ON AFTER Top thread monitor on (distance in mm after beginning of sewing process)
13	TOP THREAD MON. FILTER: Filter for top thread monitor (response delay)
14	BOTTOM THREAD MON. FILTER Filter for bottom thread monitor (response delay)
16	TACKING LENGTH SEAM BEG. Initial bar tack length (only lock stitch)

# D.3 Programming

## D.3.5 List of special parameters

No.	Programmable special parameters in list (F3)
17	TACKING LENGTH SEAM END Final bar tack length (only lock stitch)
18	STITCH LENGTH SEAM BEG: Stitch length at beginning of seam (Input 5.0 mm max.)
19	DISTANCE OF THIS ST.LEN: Distance of stitch length at beginning of seam
20	1.ST.LENGTH OF CURVE: First stitch length in curvature (Input 5.0 mm max.)
21	DIST.OF 1.STICH LENGTH: Distance of first stitch length
22	2.ST.LENGTH OF CURVE: Second stitch length in curvature (Input 5.0 mm max.)
23	DIST.OF 2.STITCH LENGTH: Distance of second stitch length
24	ST.LENGTH OF MAIN SEAM: Stitch length of main seam (Input 5.0 mm max.)
25	STITCH LENGTH SEAM END: Stitch length at end of seam (Input 5.0 mm max.)
26	DIST.OF THIS ST.LENGTH: Distance of stitch length at end of seam
27	ST.LENGTH TRIMM.STITCH: Stitch length of cutting stitch (Input 5.0 mm max.)
28	CHOICE OF TRIMMING ST.: Cutting stitch / Preselection
30	START MODUS .....: Start mode preselection
32	BLOWING MODUS .....: Blowing, mode (00 switched off - 01 switched on)
33	PUSH RETAINER MODUS: Holding stamp and ejector stamp, mode (00 switched off - 01 switched on)
34	SWING RETAINER MODUS: Ejector stamp, mode (00 switched off - 01 switched on)

# D.3 Programming

## D.3.6 Level 2 special parameters / Functions

Fig. 4/5

### Functions of level 2 submenus:

The following section describes the special parameters that can be enabled or disabled as functions.

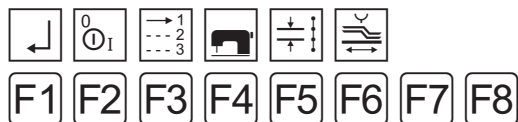

- F1 Back to start level
- F2 Enable / disable functions

### Enabling / disabling functions:

Functions can be enabled or disabled for a selected sewing program. This process covers three levels (3, 4 and 5). The changes made are reflected on the display:

**Fig. 4:** Enabled functions are displayed as symbols 1 and 2.

Fig. 4

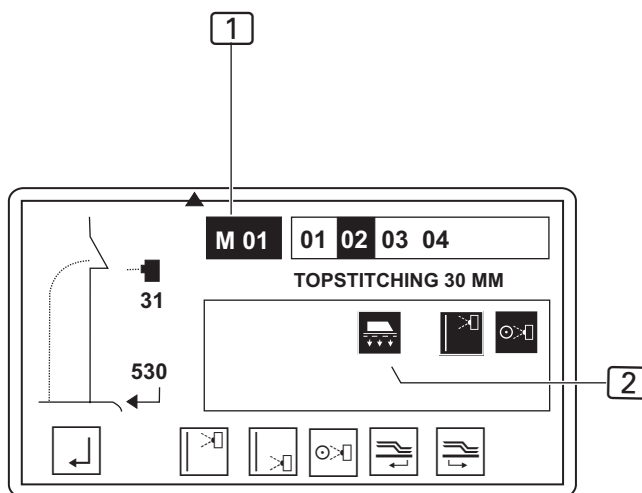

**Fig. 5:** Disabled functions are removed from the sewing pictograph 1 and from the inner section 2 of the display.

Fig. 5

Start menu:



- Press F2 key.

Level 3 is displayed.

### Level 3 submenus:



- F1 Back to start level
- F2 Switch photocell for beginning of seam on or off
- F3 Switch photocell for end of seam on or off
- F8 Request next level (level 4)

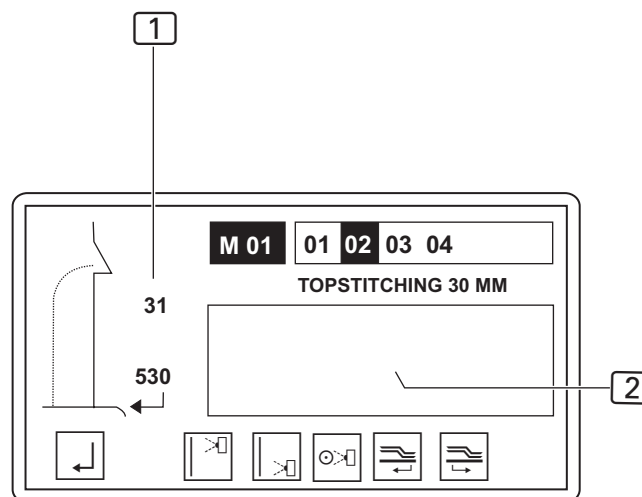

# D.3 Programming

## D.3.7 Level 3 special parameters / Functions

### ■ Switching photocell for beginning of seam on or off:

If the photocell that scans the start position of the seam is switched off, the machine control requires a fixed insertion distance for machine operation. Therefore, switching off the photocell results in a switch-over to a fixed insertion length (see Fig. 5). This function is directly related to the photocell correction functions of the service menu.



- Press **F2** key.

The alternating request of this function switches between two modes:

Photocell for beginning of seam and fixed insertion distance.

### ■ Switching photocell for end of seam on or off:

If the photocell that scans the end position of the seam is switched off, the machine control requires a fixed point for the end of the seam to ensure correct machine operation. Therefore, switching off the photocell results in a switch-over to a fixed end of seam point. This function is directly related to the photocell correction functions of the service menu.



- Press **F3** key.

The alternating request of this function switches between two modes:

Photocell for end of seam and fixed end of seam point.  
**This function can only be enabled if the function "sewing to fixed end of seam point" (level 4) is disabled.**

## D.3.8 Level 4 special parameters / Functions

### Functions of level 4 submenus:



- F1 Back to level 3
- F2 Switch vacuum on or off
- F7 Switch sewing to fixed end of seam point on or off
- F8 Request next level (level 5)

### ■ Switching vacuum supply on or off:

The vacuum used to fix the sewing piece before it is transferred to the clamp transport can be switched off while machine movements are checked. To switch the vacuum on or off:



- Press **F2** key.

### 👉 NOTE - Operation without vacuum!

During normal production, the vacuum supply should always be switched on as otherwise machine operation may be impaired.

### ■ Switching sewing to fixed end of seam point on or off:

If this function is enabled, the sewing program is set for a fixed end of seam point. In this case the function "photocell for end of seam" (level 3) is disabled.



- Press **F7** key.

# D.3 Programming

## D.3.9 Level 5 special parameters / Functions

### Functions of level 5 submenus:



- F1 Back to level 4
- F3 Switch top thread monitor on or off
- F4 Bottom thread monitor for chain stitch upper part on or off
- F5 Switch rest thread monitor for lock stitch upper part on or off
- F6 Clamp position after end of seam
- F7 Clamp waiting position

#### ■ Switching the top thread monitor on or off

For testing purposes, the top thread monitor can be switched off. To switch the top thread monitor on or off:



- Press **F3** key.

#### ☞ NOTE - Operation without top thread monitor!

During normal production, the top thread monitor should always be switched on as otherwise the sewing program will not be stopped if the thread breaks.

#### ■ Switching the rest thread monitor or bottom thread monitor on or off

Depending on the specifications of the sewing head, the machine is equipped with either a rest thread monitor (for lock stitch upper part) or a bottom thread monitor (for chain stitch upper part). Both monitors can be switched on or off for testing purposes. To switch a monitor on or off:

Enabling or disabling the function for chain stitch upper part:



- Press **F4** key.

Enabling or disabling the function for lock stitch upper part:



- Press **F5** key.

#### ☞ NOTE - Operation without thread monitor!

During normal production, the rest thread monitor or the top thread monitor should always be switched on as otherwise the sewing program will not be stopped if the thread breaks.

#### ■ Switching clamp position after end of seam on or off

If this function is enabled, the closed clamp moves to the clamp transport end point after the end of the seam before releasing the sewing piece. To enable or disable this function:



- Press **F6** key.

#### ■ Moving clamp to waiting position

If this function is enabled, the clamp moves to the waiting position (e. g. special parameter 05: 48 cm).



- Press **F7** key.

# D.3 Programming

## D.3.10 Level 2 special parameters / Lists

### Parameter settings for level 2 submenus

The following section describes the special parameters that are set in lists. When a submenu is requested, only those positions of the parameter list are displayed that refer to the machine function. All other positions of the entire parameter list can be browsed.

Move to a line in the list:

- Press  or  key.

### Functions of the special parameter menu

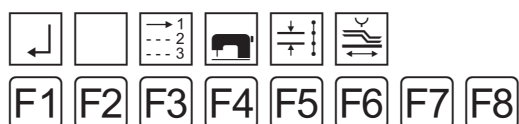

- F1 Back to start level
- F3 Select start modes, list
- F4 Set upper part parameters, list
- F5 Set stitch lengths and bar tacks, list
- F6 Parameters for clamp transport, list

### ■ Selecting modes



Four modes can be set in this menu:

- Start mode,
- Blowing mode,
- Holding stamp mode,
- Ejector stamp mode.



- Press  key.

Change parameters:

- Press  key.
- Insert new value using numeric keypad or
- Press  or  key.

Confirm input:

- Press Confirm input:
- Press  key. key.

### Settable values:

#### Start mode

The selected start mode determines how the machine operation is started and executed. Three modes are available:

- Mode 00,
- Mode 01,
- Mode 02.

The individual settings for machine operation are described in Section B.3.9, Machine operation.

#### Blowing mode

This mode determines if the function "Blow sewing piece off" is enabled or disabled after tucking.

- 00, disabled,
- 01, enabled.

#### Holding stamp mode

Two modes are available for the holding stamp. 1931-5

- Mode 00: The holding stamp is disabled.
- Mode 01: The holding stamp is lowered after the vacuum switches on and the footswitch is released. When the vacuum switches off, the holding stamp is raised



# D.3 Programming

## D.3.10 Level 2 special parameters / Lists

### ■ Setting upper part parameters:

This list is used for setting all parameters for functions of the sewing head.

The minimum and maximum values of input are limited by the program control unit. Values that are not within the limits will not be accepted but reduced to the corresponding minimum or maximum value.



- Press **F4** key.

The parameter list is shown on the display.

### **NOTE - Sewing speed!**

Possible settings for the sewing speed refer to the following sewing ranges:

- 06 sewing speed 1 to the start distance,
- 07 sewing speed 2 to the center distance,
- 08 sewing speed 3 to the end of the seam.

### ■ Setting stitch lengths and bar tacks:

All settings for the configuration of the seam can be changed using this list.

The minimum and maximum values of input are limited by the program control unit. Values that are not within the limits will not be accepted but reduced to the corresponding minimum or maximum value.



- Press **F5** key.

The parameter list is shown on the display.

### ■ Parameters for clamp transport:

This list is used to make all settings for the clamp movement.



- Press **F6** key.

The parameter list shown on the display has the following function:

- 01 Clamp insertion as seen from right end of rail
- 02 Stop position 600 mm is a safety value. Only values higher than 600 mm can be input
- 03 Settable range: 35 % - 80 %
- 04 Settable range: 35 % - 99 %
- 05 Range of the curve where no sewing is effected. If value "0" is input here, the sewing process starts immediately.

# D.4 Factory settings

## D.4.1 Factory settings for global parameters

### ■ M 01 global parameters 1931-5

Pos.	Global parameters 1931-5	Value	Unit
01	CLAMP FWD. TO PART	0.8	sec
02	TILL CLAMP DOWN	0.3	sec
03	TILL VACUUM OFF	0.3	sec
04	THREAD LENGTH, BOBBIN FULL	003	m
05	TILL CLAMP INSERTING	0.2	sec
06	SEWING END ->CL.SIDEW	0.1	sec
07	TIME AFTER CLAMP OPEN	0.5	sec
17	TILL TENSION OPEN	0.00	sec
18	DURATION OF TENS. OPEN	0.2	sec
19	TILL THREAD CLAMP FORW.	0.5	sec
20	DUR.THREAD CLAMP FORW.	0.6	sec
25	TILL FABRIC CLAMP FORW.	0,4	sec
28	TILL FABRIC CLAMP OPEN	0,2	sec
29	TILL SWING RETAINER DWN.	0,0	sec
30	TILL RETAINER SWINGS	0,0	sec
31	DUR.OF PULLING RETAINER	0,0	sec
32	BLOW OUT THE PART	0,5	sec
33	CLAMP MOVES TO STACKER	0,0	sec
35	THREAD CATCH. "UP" POS	023	INC
36	SWITCH ON POS.OF TRIMM.	100	INC
37	TRIMMING SPEED	180	Rpm
38	DURATION OF TRIMMING	0.35	sec
39	THREAD CATCH.TURNS BACK	25	INC
40	PROCESS IN STEPS	00	

# D.4 Factory settings

## D.4.2 Factory settings for special parameters

### ■ M 01 special parameters 1931-5

Pos.	SEAM 01 - STITCH WIDTHS 30 MM	Value	Unit
01	CLAMP POSITION RIGHT	240	mm
02	TILL GUIDE TO WORK POS.	700	mm
03	INSERT SPEED	50	%
04	CLAMP SPEED	85	%
05	DISTANCE TILL SEWING	02	mm
06	SEWING SPEED 1	1200	Rpm
07	SEWING SPEED 2	3800	Rpm
08	SEWING SPEED 3	1200	Rpm
09	DISTANCE SEWING SPEED 1	20	mm
10	DISTANCE SEWING SPEED 3	20	mm
12	THREAD MONITOR ON AFTER	05	mm
13	TOP THREAD MON. FILTER	20	mm
14	BOTTOM THREAD MON. FILTER	00	mm
16	TACKING LENGTH SEAM BEG	00	mm
17	TACKING LENGTH SEAM END	05	mm
18	STITCH LENGTH SEAM BEG	2.0	mm
19	DISTANCE OF THIS ST.LEN	08	mm
20	1.ST.LENGTH OF CURVE	3.7	mm
21	DIST.OF 1.STICH LENGTH	22	mm
22	2.ST.LENGTH OF CURVE	3.6	mm
23	DIST.OF 2.STITCH LENGTH	40	mm
24	ST.LENGTH OF MAIN SEAM	3.0	mm
25	STITCH LENGTH SEAM END	2.0	mm
26	DIST.OF THIS ST.LENGTH	10	mm
27	ST.LENGTH TRIMM.STITCH	1.5	mm
28	CHOICE OF TRIMMING ST	00	
30	START MODUS	01	
32	BLOWING MODUS	01	
33	PUSH RETAINER MODUS	01	
34	SWING RETAINER MODUS	00	

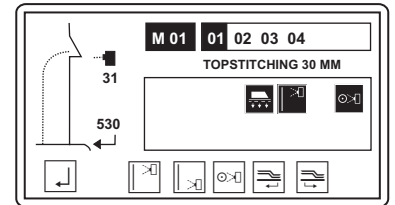

# D.4 Factory settings

## D.4.2 Factory settings for special parameters

### ■ M 01 special parameters 1931-5

Pos.	SEAM 01 - STITCH WIDTCH 30 MM	Value	Unit
01	CLAMP POSITION RIGHT	300	mm
02	TILL GUIDE TO WORK POS.	720	mm
03	INSERT SPEED	50	%
04	CLAMP SPEED	85	%
05	DISTANCE TILL SEWING	02	mm
06	SEWING SPEED 1	1200	Rpm
07	SEWING SPEED 2	3800	Rpm
08	SEWING SPEED 3	1200	Rpm
09	DISTANCE SEWING SPEED 1	20	mm
10	DISTANCE SEWING SPEED 3	20	mm
12	THREAD MONITOR ON AFTER	10	mm
13	TOP THREAD MON. FILTER	20	mm
14	BOTTOM THREAD MON. FILTER	00	mm
16	TACKING LENGTH SEAM BEG	00	mm
17	TACKING LENGTH SEAM END	08	mm
18	STITCH LENGTH SEAM BEG	2.0	mm
19	DISTANCE OF THIS ST.LEN	08	mm
20	1.ST.LENGTH OF CURVE	3.7	mm
21	DIST.OF 1.STICH LENGTH	22	mm
22	2.ST.LENGTH OF CURVE	3.6	mm
23	DIST.OF 2.STITCH LENGTH	40	mm
24	ST.LENGTH OF MAIN SEAM	3.0	mm
25	STITCH LENGTH SEAM END	2.0	mm
26	DIST.OF THIS ST.LENGTH	10	mm
27	ST.LENGTH TRIMM.STITCH	1.5	mm
28	CHOICE OF TRIMMING ST	00	
30	START MODUS	01	
32	BLOWING MODUS	01	
33	PUSH RETAINER MODUS	01	
34	SWING RETAINER MODUS	01	

